

PART NUMBER	REVISION	DESCRIPTION	FEED TYPE
2150466-2	D	FINE CRIMP HEIGHT ADJUST	PNEUMATIC
7-2150466-2	D	PNEUMATIC AND CRIMP TOOLING KIT	PNEUMATIC
7-2150466-7	C	CRIMP TOOLING KIT	-

ATLANTIC VERSION TERMINATOR INTERFACE ADAPTER

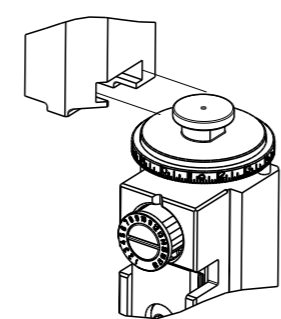

APPLICATOR DATA		
CRIMP	SIZE	TYPE
WIRE	3.00 mm [.118]	F
INSUL	4.00 mm [.157]	F
APPL INSTRUCTIONS 408-35043		

TERMINAL DATA: SAMSUNG TERMINAL SAMSUNG CRIMP SPECIFICATION			
TERMINAL NAME: TERMINAL-RECEPTACLE(S48F)			
WIRE STRIP LENGTH		INSULATION DIAMETER RANGE	
TERMINAL APPLICATION SPECIFICATION	SAMSUNG TOOLING DRAWING L TYPE		
TERMINALS APPLIED			
TE TERMINAL	SAMSUNG TERMINAL	TE TERMINAL	SAMSUNG TERMINAL
2113583-1	35454-8902	2113583-2	DB65-00307B

WIRE SIZE	CRIMP HEIGHT mm [INCH]	CRIMP HEIGHT REFERENCE SETTING
1.0mm + 1.1mm SOLID	1.84+/-0.04 [.072+/- .002]	6.0

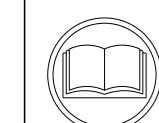

- RECOMMENDED SPARE PARTS
 - REFER TO SUPPLIED INSTRUCTION SHEET FOR CLEANING, LUBRICATION AND STORAGE OF APPLICATOR.
 - APPLY PART NUMBER 1-23419-5 LOCTITE TO THREADS OF ITEMS 180. APPLY PART NUMBER 2-23419-6 LOCTITE TO THREADS OF ITEM 242.
 - CRIMP HEIGHT REFERENCE SETTING WAS THE SETTING USED WHEN THE APPLICATOR WAS QUALIFIED AT THE FACTORY. ADJUSTMENT MAY BE NECESSARY WHEN RUNNING APPLICATOR IN THE FIELD.
 - TERMINAL PITCH NOT COMPATIBLE WITH MECHANICAL FEED.
 - CUT TO LENGTH AT ASSEMBLY.
 - APPLICATOR APPLIES SOLID WIRE ONLY.
 - TERMINAL LUBRICANT IS RECOMMENDED.
9. UNLESS SPECIFIED OTHERWISE TORQUE VALUES SHALL BE USED PER DOCUMENT, 101-35000.

***WARNING**
ON INSTALLATION, SET WIRE DISC TO CRIMP HEIGHT REFERENCE SETTING FOR LARGEST WIRE SIZE. CRIMP HEIGHT REFERENCE SETTINGS GREATER THAN THE VALUE SHOWN MAY CAUSE DAMAGE TO THE CRIMP TOOLING, REFER TO THE INSTRUCTION SHEET FOR PROPER SETUP AND ADJUSTMENTS.

LOC	DIST	REVISIONS					
		P	LY#	DESCRIPTION	DATE	OWN	APVD
A	66	C		ECR-15-008886	16 JUN 2015	MR	TE
		D		ECR-19-016495	23 OCT 2019	FJ	TE

-	1	1	1803078-3	SPACER, PRECISION	259
-	1	1	2119641-1	FEED CAM, AIR FEED	248
-	1	1	2119082-8	CAM, SNAIL, INSULATION ADJUSTMENT	244
-	1	1	2079764-1	WASHER, WAVE SPRING, CREST-TO-CREST	243
	-	1	2119083-1	RETAINER, INSULATION DIAL	242
-	-	-	2119580-1	MECHANICAL FEED ASSEMBLY	239
-	1	1	2844940-4	AIR FEED MODULE	238
-	1	1	1-18028-0	WASHER, FLAT, REG M8	192
-	REF	REF	994970-2	COUNTER, MAGNETIC	164
	-	1	2119955-2	ASSY, LUBRICATOR, END FEED	84
-	1	1	455888-6	SPACER, CRIMPER	82
-	1	1	1803607-4	DOCUMENTATION PACKAGE	71
-	2	2	2-18032-2	SCR, SET, FLT PNT, M3 X 10.0	70
-	1	1	2119740-1	TAG, IDENTIFICATION	67
-	2	2	2168078-1	SCREW, DRIVE, RH, RoHS, 2 x .188	66
-	1	1	2168083-2	SCR, SKT HD CAP, RoHS, M4 X 8.0	60
-	1	1	5-18022-5	SCR, HEX HD CAP, M4 X 6.0	59
-	-	-	2063961-1	FEED FINGER	58
	-	4	2168400-4	SHCS, LOW HEAD, RoHS, M4 X 8	57
-	2	2	2168083-2	SCR, SKT HD CAP, RoHS, M4 X 8.0	56
-	2	2	5018030-1	NUT, HEX, REG, RoHS, M3	54
-	2	2	986965-8	NUT, LOCK, HEX, TORQUE (M4)	53
-	1	1	2063961-1	FEED FINGER	51
-	1	1	18023-9	SCR, SKT HD CAP M4 X 6.0	49
-	-	-	2119652-1	FEED CAM, PRE FEED	48
-	-	-	2119653-1	FEED CAM, POST FEED	47
-	1	1	2119655-5	APPLICATOR BASIC ASSEMBLY, EF	46
-	1	1	1803517-2	RAM ASSEMBLY, EF ATLANTIC	44
-	1	1	1803602-2	SCR, BHSC, RoHS (M8 X 40)	41
-	8	8	1-18028-2	WASHER, FLAT, REG M4	33
-	2	2	2168083-8	SCR, SKT HD CAP, RoHS, M4 X 16	31
-	2	2	1-2168083-0	SCR, SKT HD CAP, RoHS, M4 X 10	29
-	1	1	240639-1	STRIPPER (MACHINING)	27
-	2	2	1-2168083-5	SCR, SKT HD CAP, RoHS, M4 X 30	25
-	1	1	1752371-5	PLATE, STRIP GUIDE	24
-	2	2	2-22281-3	SPRING, COMPRESSION	22
-	1	1	1803292-4	DRAG	20
-	2	2	1901259-5	GUIDE, LOWER STRIP	18
	-	4	1-2079383-1	SCR, BHSC, RoHS (M6 X 12)	17
-	1	1	240644-1	PLATE, REAR SHEAR	11
-	-	-	-	-	10
	-	1	690482-6	PLATE, FRONT SHEAR	9
	1	2	2234631-3	ANVIL, COMBINATION	8
	-	1	2217206-4	BLADE, SLUG	7
-	-	-	-	-	6
-	1	1	4-240641-8	SPACER	5
-	1	1	4-238011-4	BLOCK, CRIMPER SPACER	4
	1	2	1-1803187-2	CRIMPER, INSULATION F	3
-	1	1	455888-7	SPACER, CRIMPER	2
	1	2	1633893-4	CRIMPER, WIRE PREMIUM	1
-	77	72	2	PART NO	ITEM NO

ATLANTIC VERSION
Shown on sheets 1 of 4 & 2 of 4
(Pacific version shown on sheets 3 of 4 & 4 of 4)

<small>THE DRAWING IS CONTROLLED BY THE DRAWING REVISIONS CONTROL SYSTEM. ANY CHANGES TO THE DRAWING MUST BE MADE THROUGH THE REVISIONS CONTROL SYSTEM. THIS DRAWING IS THE PROPERTY OF TYCO ELECTRONICS CORPORATION AND IS NOT TO BE REPRODUCED OR TRANSMITTED IN ANY FORM OR BY ANY MEANS, ELECTRONIC OR MECHANICAL, INCLUDING PHOTOCOPYING, RECORDING, OR BY ANY INFORMATION STORAGE AND RETRIEVAL SYSTEM. WITHOUT PERMISSION IN WRITING FROM TYCO ELECTRONICS CORPORATION.</small>		DWG: B. WEAVER 13OCT2014 CHK: G. BAILEY 13OCT2014 APVD: G. BAILEY 13OCT2014	TE Connectivity Harrisburg, PA 17105-3608
DIMENSIONS: mm 		TOLERANCES UNLESS OTHERWISE SPECIFIED: 0 PLC ±.5 1 PLC ±0.5 2 PLC ±0.13 3 PLC ±0.013 4 PLC ±0.0001 ANGLES FINISH ±.	NAME: Ocean End Feed Applicator SIZE: A1 CAGE CODE: 00779 DRAWING NO: 2150466 RESTRICTED TO: -
MATERIAL: -		WEIGHT: - SCALE: 1:1 SHEET: 1 OF 4 REV: D	Customer Accessible Production Drawing

LOC	DIST	REVISIONS					
A	66	P	LYR	DESCRIPTION	DATE	OWN	APVD
		-		SEE SHEET 1	-	-	-

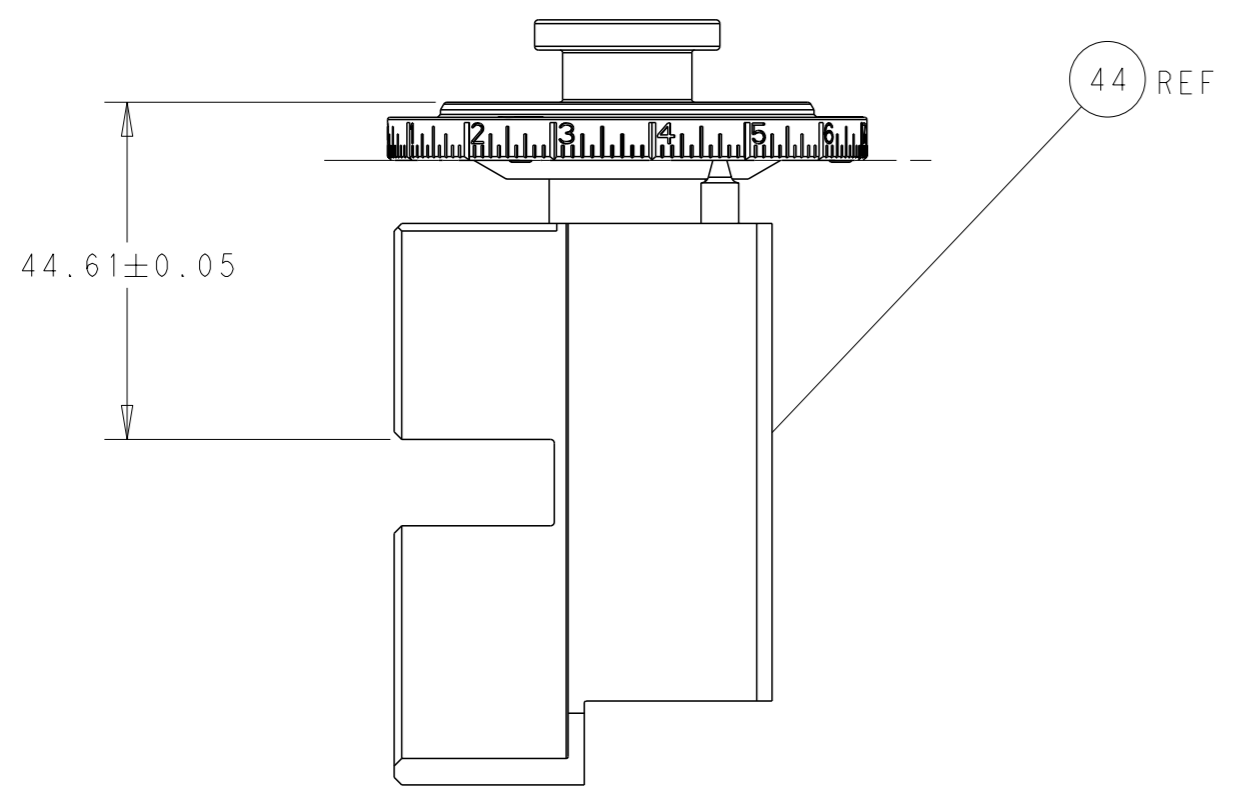

RAM SET-UP

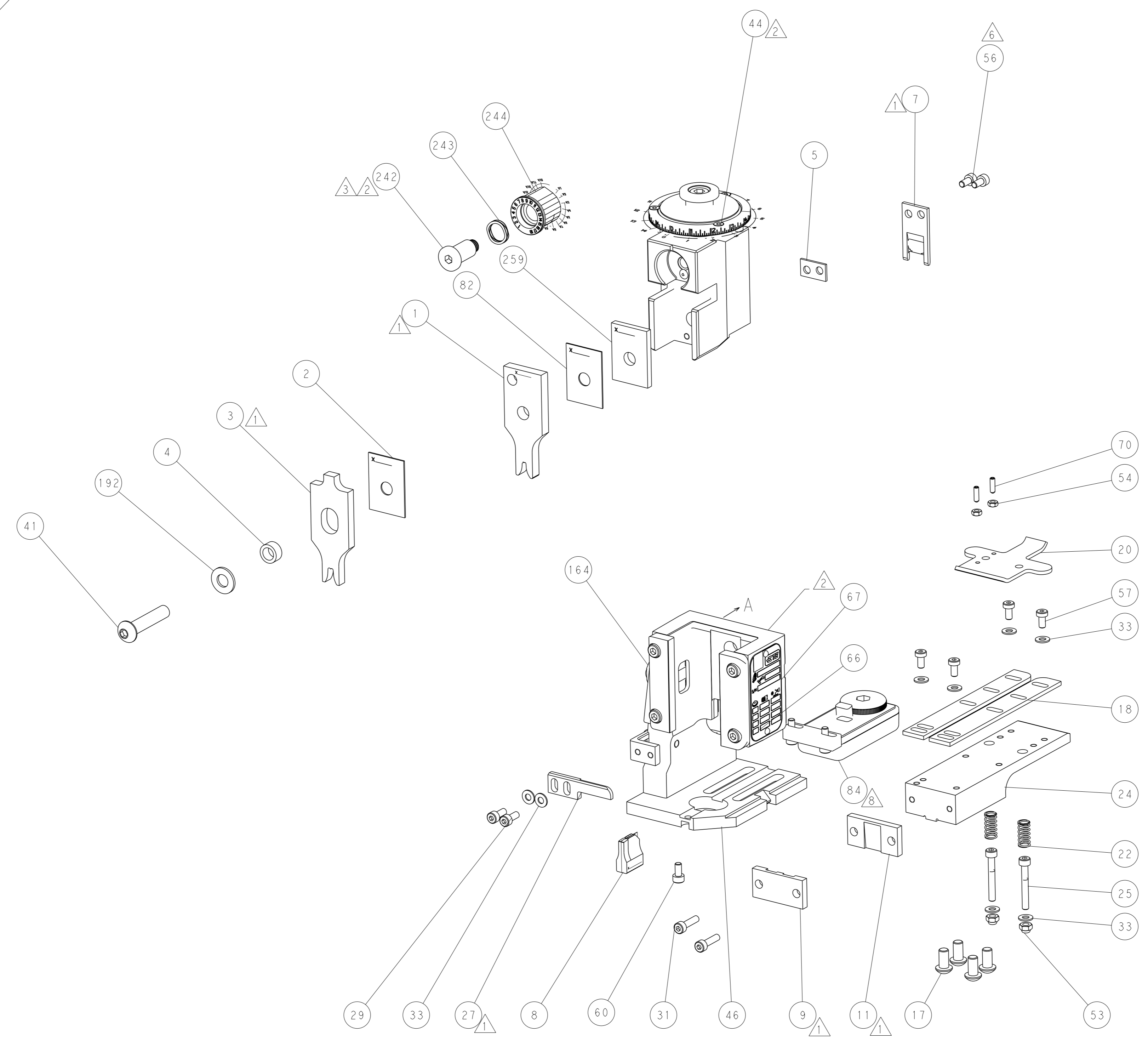

FEED TYPE

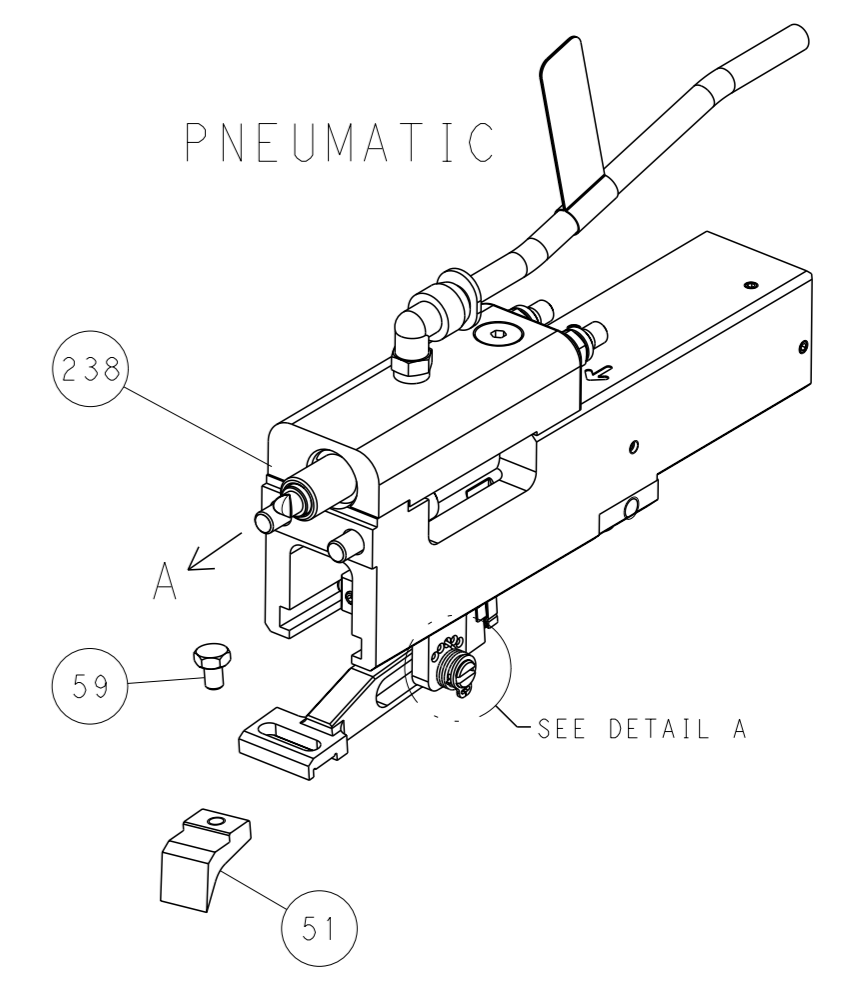

FEED SPRING SETTING POSITION

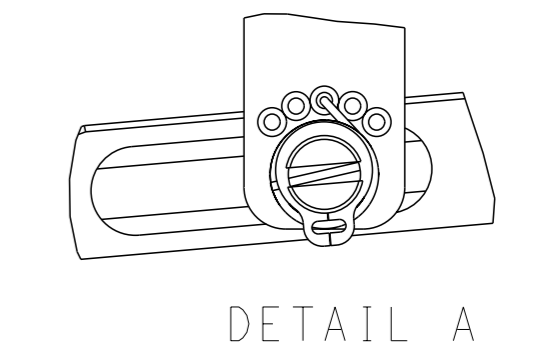

CAM POSITION

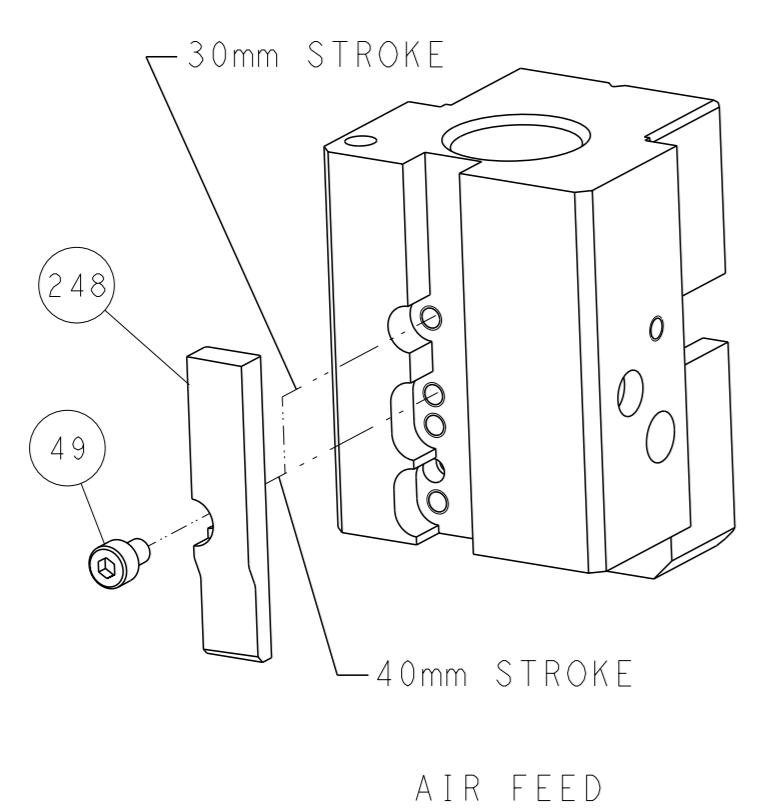

ATLANTIC VERSION
 Shown on sheets 1 of 4 & 2 of 4
 (Pacific version shown on sheets 3 of 4 & 4 of 4)

<small>THIS DRAWING IS UNPUBLISHED. RELEASED FOR PUBLICATION 2014. COPYRIGHT 2014 BY TYCO ELECTRONICS CORPORATION. ALL RIGHTS RESERVED.</small>		OWN: B. WEAVER CHK: G. BAILEY APVD: G. BAILEY	13OCT2014 13OCT2014 13OCT2014	TE Connectivity Harrisburg, PA 17105-3608
DIMENSIONS: mm TOLERANCES UNLESS OTHERWISE SPECIFIED: 0 PLC ±.5 1 PLC ±0.13 2 PLC ±0.13 3 PLC ±0.013 4 PLC ±0.0001 ANGLES FINISH ±.		NAME: Ocean End Feed Applicator PRODUCT SPEC: - APPLICATION SPEC: -	SIZE: A1 CAGE CODE: 00779 DRAWING NO: C=2150466	RESTRICTED TO: - SCALE: 1:1 SHEET: 2 of 4 REV: D
MATERIAL: - FINISH: -		WEIGHT: - Customer Accessible Production Drawing	SHEETS 3 & 4 ARE NOT REQUIRED FOR ATLANTIC VERSION	

8	7	6	5	4	3	2	1
THIS DRAWING IS UNPUBLISHED.		RELEASED FOR PUBLICATION		2014			
COPYRIGHT 2014 BY TYCO ELECTRONICS CORPORATION. ALL RIGHTS RESERVED.							
PART NUMBER	REVISION	DESCRIPTION	FEED TYPE				
2-2150466-2	D	FINE CRIMP HEIGHT ADJUST	PNEUMATIC				
7-2150466-7	C	CRIMP TOOLING KIT	-				

PACIFIC VERSION TERMINATOR
INTERFACE ADAPTER

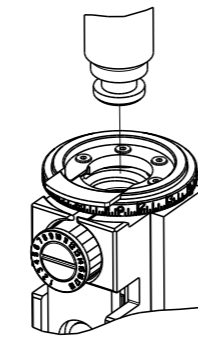

APPLICATOR DATA		
CRIMP	SIZE	TYPE
WIRE	3.00 mm [.118]	F
INSUL	4.00 mm [.157]	F
APPL INSTRUCTIONS 408-35043		

TERMINAL DATA: SAMSUNG TERMINAL SAMSUNG CRIMP SPECIFICATION			
TERMINAL NAME: TERMINAL-RECEPTACLE(S48F)			
WIRE STRIP LENGTH		INSULATION DIAMETER RANGE	
TERMINAL APPLICATION SPECIFICATION	SAMSUNG TOOLING DRAWING L TYPE	-	-
TERMINALS APPLIED			
TE TERMINAL	SAMSUNG TERMINAL	TE TERMINAL	SAMSUNG TERMINAL
2113583-1	35454-8902	2113583-2	DB65-00307B

WIRE SIZE	CRIMP HEIGHT mm [INCH]	CRIMP HEIGHT REFERENCE SETTING
1.0mm + 1.1mm SOLID	1.84 +/- 0.04 [.072 +/- .002]	6.0

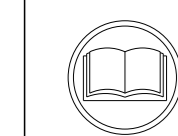

- RECOMMENDED SPARE PARTS
 - REFER TO SUPPLIED INSTRUCTION SHEET FOR CLEANING, LUBRICATION AND STORAGE OF APPLICATOR.
 - APPLY PART NUMBER 1-23419-5 LOCTITE TO THREADS OF ITEMS 180. APPLY PART NUMBER 2-23419-6 LOCTITE TO THREADS OF ITEM 242.
 - CRIMP HEIGHT REFERENCE SETTING WAS THE SETTING USED WHEN THE APPLICATOR WAS QUALIFIED AT THE FACTORY. ADJUSTMENT MAY BE NECESSARY WHEN RUNNING APPLICATOR IN THE FIELD.
 - TERMINAL PITCH NOT COMPATIBLE WITH MECHANICAL FEED.
 - CUT TO LENGTH AT ASSEMBLY.
 - APPLICATOR APPLIES SOLID WIRE ONLY.
 - TERMINAL LUBRICANT IS RECOMMENDED.
9. UNLESS SPECIFIED OTHERWISE TORQUE VALUES SHALL BE USED PER DOCUMENT, 101-35000.

***WARNING**
ON INSTALLATION, SET WIRE DISC TO CRIMP HEIGHT REFERENCE SETTING FOR LARGEST WIRE SIZE. CRIMP HEIGHT REFERENCE SETTINGS GREATER THAN THE VALUE SHOWN MAY CAUSE DAMAGE TO THE CRIMP TOOLING, REFER TO THE INSTRUCTION SHEET FOR PROPER SETUP AND ADJUSTMENTS.

PACIFIC VERSION
Shown on sheets 3 of 4 & 4 of 4
(Atlantic version shown on sheets 1 of 4 & 2 of 4)

LOC	DIST	REVISIONS					
A	66	P	LYR	DESCRIPTION	DATE	OWN	APVD
		-		SEE SHEET 1	-	-	-

-	1	1803078-3	SPACER, PRECISION	259
-	1	2119082-8	CAM, SNAIL, INSULATION ADJUSTMENT	244
-	1	2079764-1	WASHER, WAVE SPRING, CREST-TO-CREST	243
-	1	2119083-1	RETAINER, INSULATION DIAL	242
-	-	2119580-1	MECHANICAL FEED ASSEMBLY	239
-	1	2844940-4	AIR FEED MODULE	238
-	1	1-18028-0	WASHER, FLAT, REG M8	192
-	4	2079383-9	SCR, BHSC, RoHS (M6 X 20)	186
-	REF	994970-2	COUNTER, MAGNETIC	164
-	1	2119641-2	FEED CAM, AIR FEED	152
-	1	2168083-8	SCR, SKT HD CAP, RoHS, M4 X 16	144
-	-	2119653-2	FEED CAM, POST FEED	142
-	1	2119655-6	APPLICATOR BASIC ASSEMBLY, EF	141
-	1	1803518-2	RAM ASSEMBLY, EF PACIFIC	140
-	1	2119955-2	ASSY, LUBRICATOR, END FEED	84
-	1	455888-6	SPACER, CRIMPER	82
-	1	1803607-4	DOCUMENTATION PACKAGE	71
-	2	2-18032-2	SCR, SET, FLT PNT, M3 X 10.0	70
-	1	2119740-1	TAG, IDENTIFICATION	67
-	2	2168078-1	SCREW, DRIVE, RH, RoHS, 2 x .188	66
-	1	5-18022-5	SCR, HEX HD CAP, M4 X 6.0	59
-	-	2063961-1	FEED FINGER	58
-	4	2168400-4	SHCS, LOW HEAD, RoHS, M4 X 8	57
-	2	2168083-2	SCR, SKT HD CAP, RoHS, M4 X 8.0	56
-	2	5018030-1	NUT, HEX, REG, RoHS, M3	54
-	2	986965-8	NUT, LOCK, HEX, TORQUE (M4)	53
-	1	2063961-1	FEED FINGER	51
-	1	18023-9	SCR, SKT HD CAP M4 X 6.0	49
-	-	2119652-1	FEED CAM, PRE FEED	48
-	1	1803602-2	SCR, BHSC, RoHS (M8 X 40)	41
-	8	1-18028-2	WASHER, FLAT, REG M4	33
-	2	2168083-8	SCR, SKT HD CAP, RoHS, M4 X 16	31
-	2	1-2168083-0	SCR, SKT HD CAP, RoHS, M4 X 10	29
-	1	240639-1	STRIPPER (MACHINING)	27
-	2	1-2168083-5	SCR, SKT HD CAP, RoHS, M4 X 30	25
-	1	1752371-5	PLATE, STRIP GUIDE	24
-	2	2-22281-3	SPRING, COMPRESSION	22
-	1	1803292-4	DRAG	20
-	2	1901259-5	GUIDE, LOWER STRIP	18
-	1	240644-1	PLATE, REAR SHEAR	11
-	-	-	-	10
-	1	690482-6	PLATE, FRONT SHEAR	9
1	1	2234631-3	ANVIL, COMBINATION	8
-	1	2217206-4	BLADE, SLUG	7
-	-	-	-	6
-	1	4-240641-8	SPACER	5
-	1	4-238011-4	BLOCK, CRIMPER SPACER	4
1	1	1-1803187-2	CRIMPER, INSULATION F	3
-	1	455888-7	SPACER, CRIMPER	2
1	1	1633893-4	CRIMPER, WIRE PREMIUM	1
-	77-22	PART NO	DESCRIPTION	ITEM NO

DIMENSIONS: mm 		TOLERANCES UNLESS OTHERWISE SPECIFIED: 0 PLC ±.5 1 PLC ±0.13 3 PLC ±0.013 4 PLC ±0.0001 ANGLES FINISH ±.		DWG: B. WEAVER 13OCT2014 CHK: G. BAILEY 13OCT2014 APVD: G. BAILEY 13OCT2014 PRODUCT SPEC APPLICATION SPEC		NAME: STE TE Connectivity Harrisburg, PA 17105-3608 Ocean End Feed Applicator	
MATERIAL: .		WEIGHT: .		SIZE: A1		CAGE CODE: 00779	
Customer Accessible Production Drawing		SCALE: 1:1		SHEET: 3 of 4		REV: D	

LOC	DIST	REVISIONS			
A	66	REV	DATE	OWN	APVD
-	-	SEE SHEET 1	-	-	-

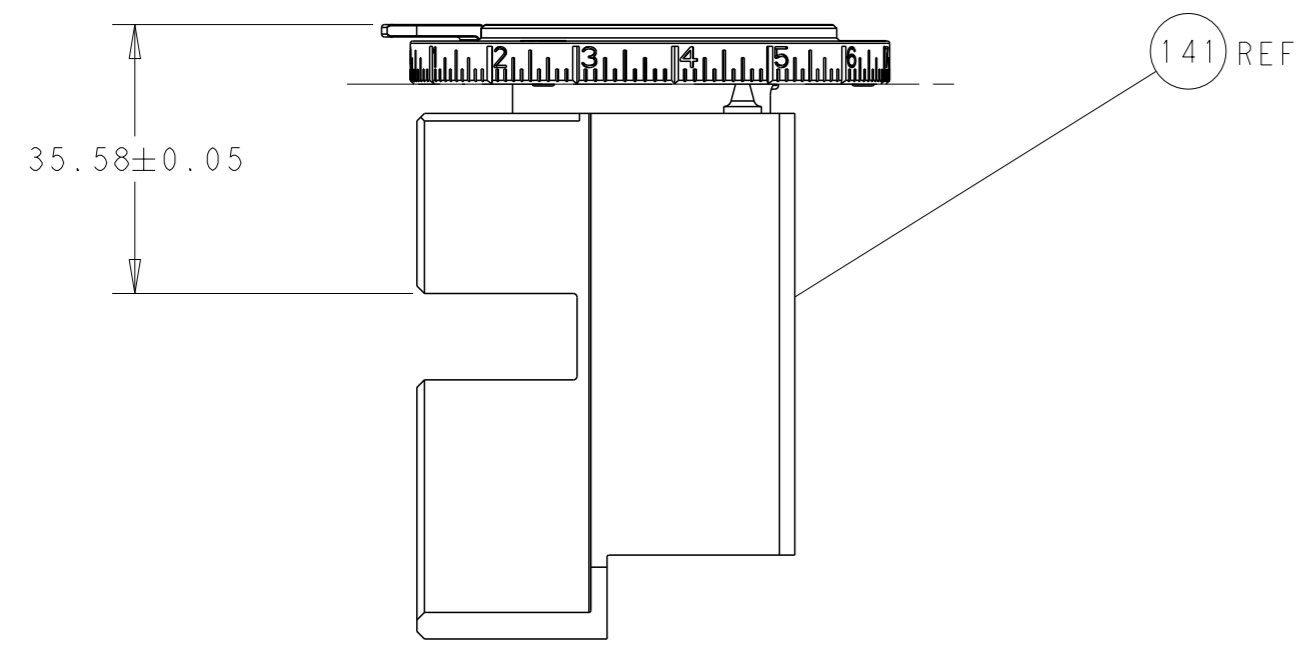

RAM SET-UP

FEED TYPE

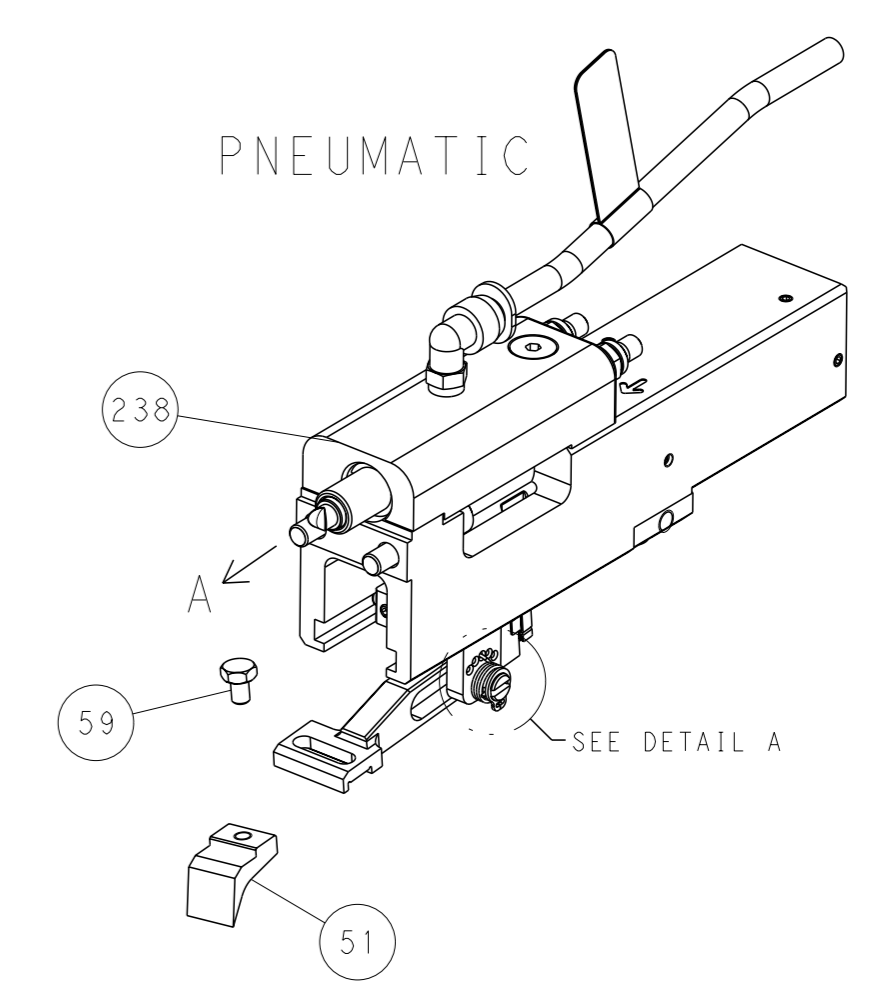

PNEUMATIC

FEED SPRING SETTING POSITION

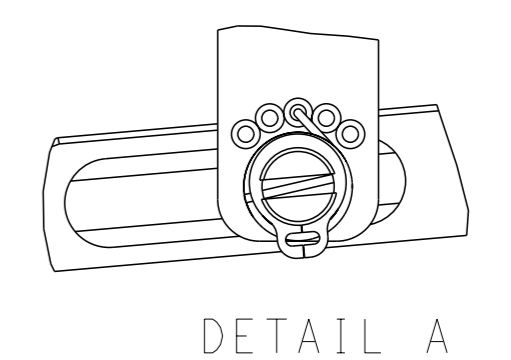

DETAIL A

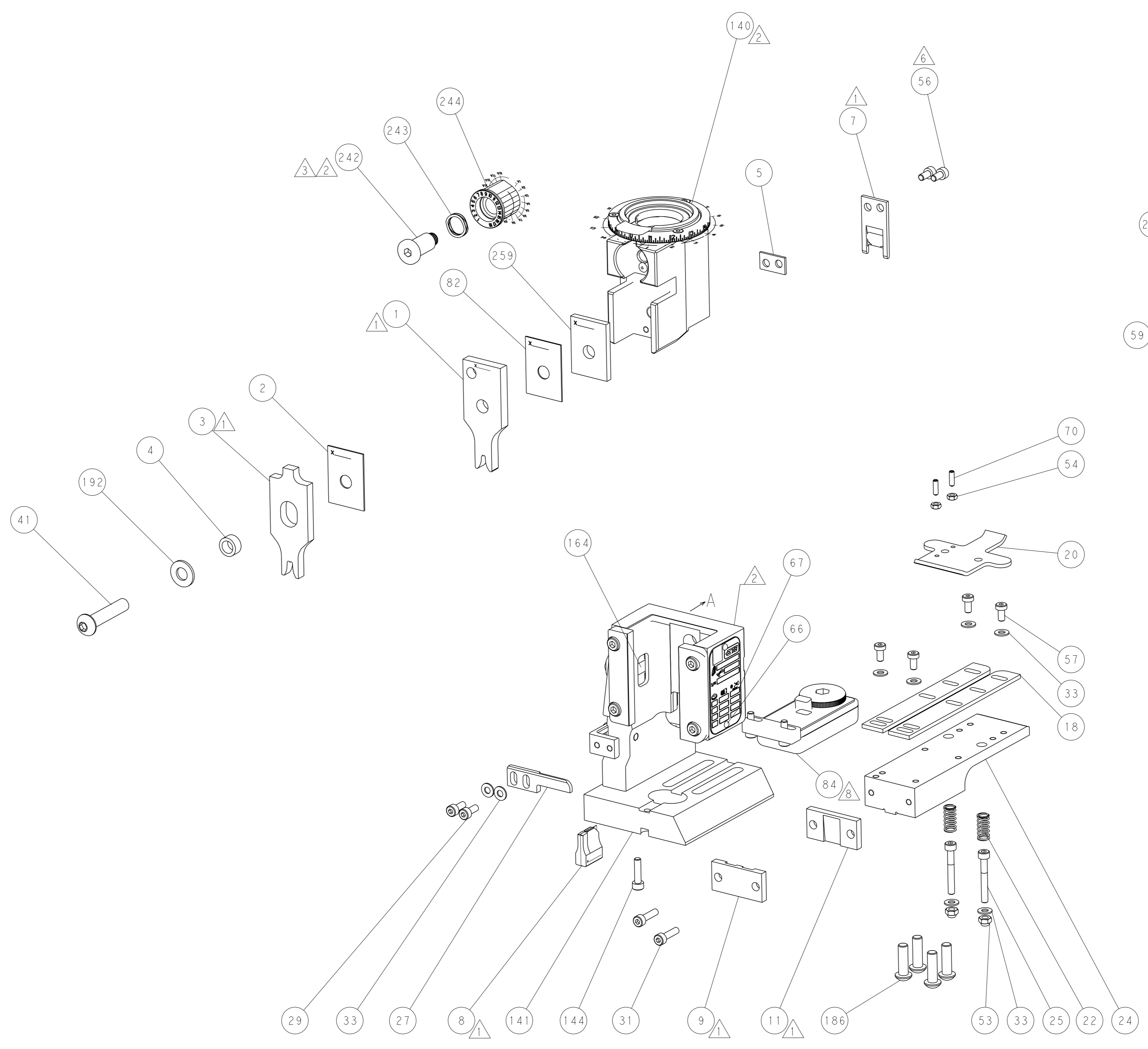

CAM POSITION

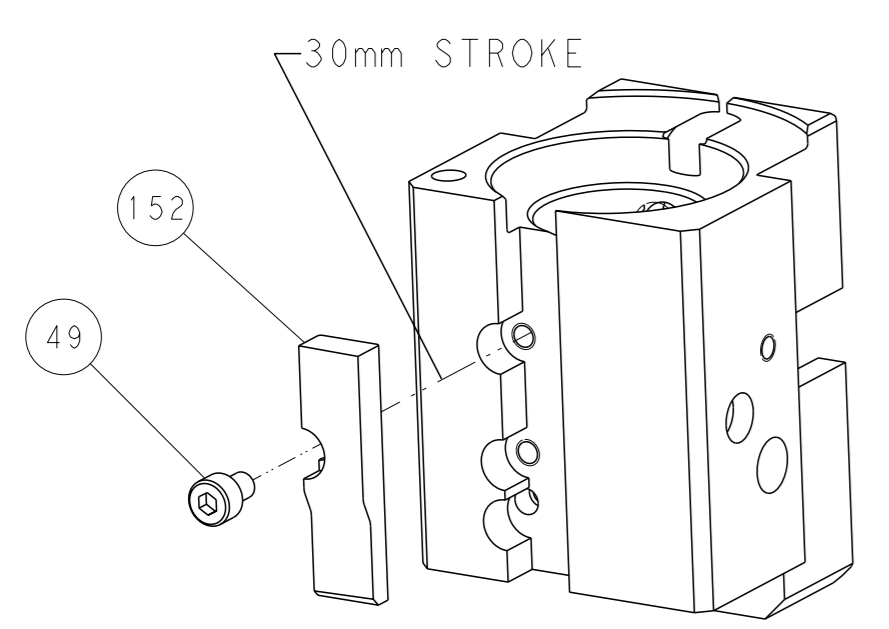

AIR FEED

PACIFIC VERSION
 Shown on sheets 3 of 4 & 4 of 4
 (Atlantic version shown on sheets 1 of 4 & 2 of 4)

<small>THIS DRAWING IS A CONTROLLED DOCUMENT FOR TYCO ELECTRONICS CORPORATION. IT IS SUBJECT TO CHANGE AND THE USER'S RESPONSIBILITY TO VERIFY THE LATEST REVISION SHOULD BE CONTACTED FOR THE LATEST REVISION.</small>		DWN B. WEAVER 13OCT2014 CHK G. BAILEY 13OCT2014 APVD G. BAILEY 13OCT2014	TE Connectivity Harrisburg, PA 17105-3608
DIMENSIONS: mm TOLERANCES UNLESS OTHERWISE SPECIFIED: 0 PLC ±.5 1 PLC ±0.13 2 PLC ±0.13 3 PLC ±0.013 4 PLC ±0.001 ANGLES FINISH *		NAME Ocean End Feed Applicator APPLICATION SPEC WEIGHT SCALE 1:1	RESTRICTED TO SIZE CAGE CODE DRAWING NO. A1 00779 C=2150466 SHEET 4 OF 4 REV D
MATERIAL:		Customer Accessible Production Drawing	SHEETS 1 & 2 ARE NOT REQUIRED FOR PACIFIC VERSION