



CODE 41 - BRAID TAIL BACKSHELL

204M216-19B08

SERIES _____
 ORDER NUMBER (TABLE 1) _____
 MATERIAL _____
 REFER TO CH00-0250-004
 FINISH _____
 REFER TO CH00-0250-004 ②
 ENTRY SIZE (TABLE 2) _____

NOTES:

1. THIS PRODUCT IS DESIGNED TO TERMINATE A HEAT SHRINKABLE LIPPED BOOT TO A CONNECTOR.
- ② FOR ADDITIONAL DIMENSIONS, ORDERING INFORMATION AND MODIFICATIONS, SEE CH00-0250-004.
3. BACKSHELL TO BE PERMANENTLY MARKED/BAGGED AND LABELLED WITH CODE IDENTIFICATION NUMBER AND PART NUMBER. (e.g. 06090-204M212-19B08).
- ④ WHEN ENTRY SIZE EXCEEDS "MAX ENTRY", A 2 PIECE BACKSHELL (TYPE 2) IS SUPPLIED.
5. BRAID TERMINATION RING MAY BE SUPPLIED AS TINEL-LOCK SHAPE MEMORY RING AT MANUFACTURERS OPTION.
6. BACKSHELL MATES TO MIL-DTL-38999, SERIES I AND II, CLASS E AND T, MS27466, MS27467, MS27468, MS27472, MS27473, MS27474, MS27479, MS27480, MS27481, MS27484, MS27497, MS27652, MS27653, MS27656 CONNECTORS.

| | | | | | | |
|--|---------------------------|---------------------------|---|--|----------------------|--|
| DRAWN | K.WINCZURA | DATE 18/02/2015 |  3RD ANGLE PROJECTION NOT TO SCALE | TITLE: | BRAID TAIL BACKSHELL |  Polamco  TE connectivity |
| CHECKED | | 18/02/2015 | | | | |
| APPROVED | K.SHEPPARD | 24/02/2015 | | UNLESS OTHERWISE SPECIFIED ALL DIMENSIONS IN MILLIMETRES GENERAL TOL LINEAR +/-0.25MM ANGULAR +/- 1° | | |
| APPROVED | H.SMITH | 05/10/2015 | | | | |
| REVISIONS | | | | | | |
| LTR | DESCRIPTION | DATE | APPROVED | | | |
| M | REVISED PER ECO-15-003780 | 16.03.15 | I.MYONG | | | |
| N | REVISED PER ECO-15-013980 | 05.10.15 | H.SMITH | | | |
| TE CAGE CODE: 06090 POLAMCO/TE CAGE CODE: U5792 | | | | TE CONNECTIVITY - POLAMCO LTD RESERVES THE RIGHT TO AMEND THIS DRAWING AND THE INFORMATION SET FORTH HEREON AT ANY TIME. USERS SHOULD INDEPENDENTLY EVALUATE THE SUITABILITY OF THE PRODUCT FOR THEIR APPLICATION. | | DRAWING NO: 204M2XX |
| | | | | DRAWING REV: N | | SHT 1 |

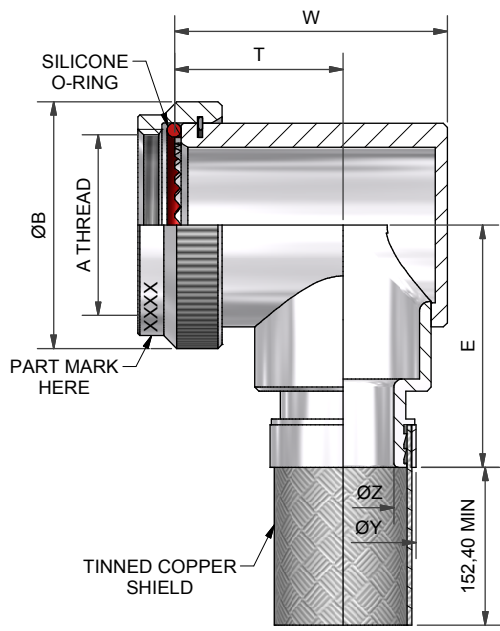

90° BACKSHELL - TYPE 1

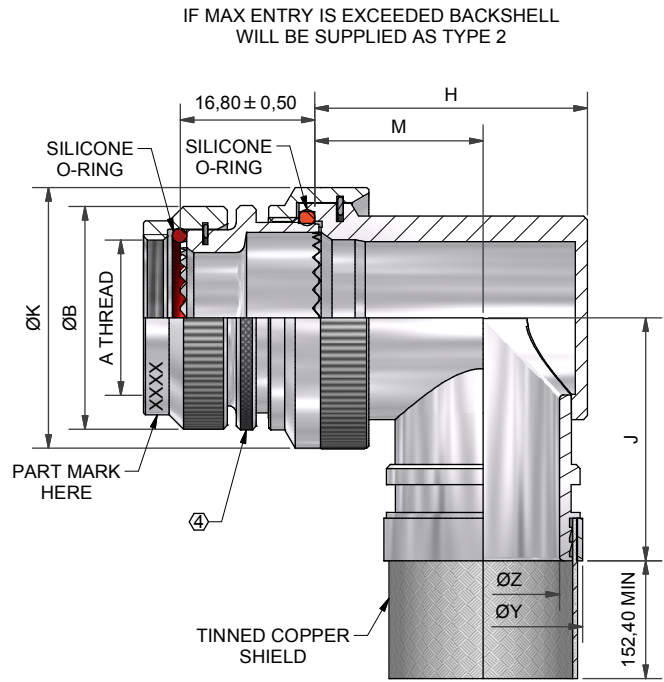

90° BACKSHELL - TYPE 2

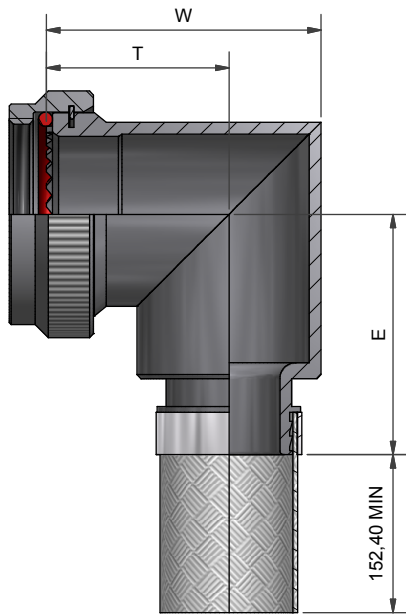

90° BACKSHELL - TYPE 1
STAINLESS STEEL AND
NICKEL ALUMINIUM BRONZE

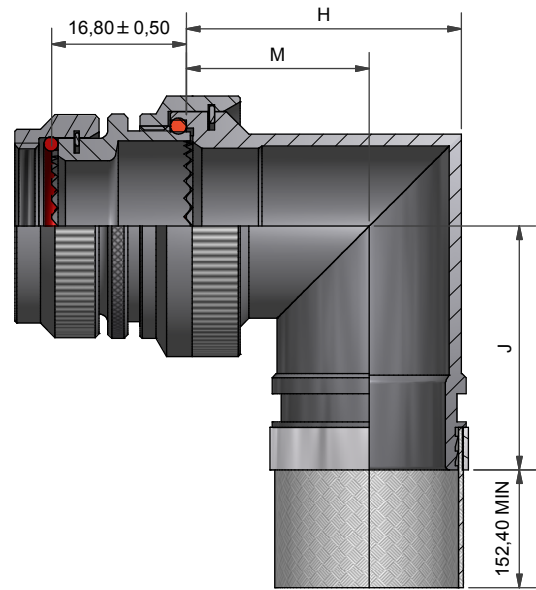

90° BACKSHELL - TYPE 2
STAINLESS STEEL AND
NICKEL ALUMINIUM BRONZE

| | | | |
|------------------|---------------------------|---------------------------|---|
| DRAWN | K.WINCZURA | DATE 18/02/2015 |  3RD ANGLE PROJECTION NOT TO SCALE |
| CHECKED | | 18/02/2015 | |
| APPROVED | K.SHEPPARD | 24/02/2015 | |
| APPROVED | H.SMITH | 05/10/2015 | |
| REVISIONS | | | |
| LTR | DESCRIPTION | DATE | APPROVED |
| M | REVISED PER ECO-15-003780 | 16.03.15 | I.MYONG |
| N | REVISED PER ECO-15-013980 | 05.10.15 | H.SMITH |

TITLE:
BRAID TAIL BACKSHELL

ASSY USED ON:
MIL-DTL-38999 SERIES I & II



TE CAGE CODE: 06090
POLAMCO/TE CAGE CODE: U5792

TE CONNECTIVITY - POLAMCO LTD RESERVES THE RIGHT TO AMEND THIS DRAWING AND THE INFORMATION SET FORTH HEREON AT ANY TIME. USERS SHOULD INDEPENDENTLY EVALUATE THE SUITABILITY OF THE PRODUCT FOR THEIR APPLICATION.

| | | |
|-------------------------------|--------------------------|-----------------|
| DRAWING NO: 204M2XX | DRAWING REV: N | SHT 2 |
|-------------------------------|--------------------------|-----------------|

TABLE 1

| ORDER NUMBER | SHELL SIZE SER I / SER II | A THREAD | ØB MAX | MAX ENTRY (4) | W ±0,5 | T ±0,5 | E ±0,5 | THESE DIMENSIONS APPLY IF BACKSHELL IS STAINLESS STEEL OR NICKEL ALUMINIUM BRONZE | | |
|--------------|---------------------------|---------------|--------|---------------|--------|--------|--------|---|--------|--------|
| | | | | | | | | W ±0,5 | T ±0,5 | E ±0,5 |
| 08 | 9 / 8 | 7/16-28UNEF | 18,3 | 04 | 21,0 | 14,0 | 24,0 | 21,3 | 16,4 | 24,0 |
| 10 | 11 / 10 | 9/16-24UNEF | 21,5 | 06 | 24,0 | 15,5 | 25,7 | 24,4 | 17,3 | 25,7 |
| 12 | 13 / 12 | 11/16-24UNEF | 24,5 | 08 | 27,0 | 17,0 | 27,2 | 28,4 | 19,5 | 27,2 |
| 14 | 15 / 14 | 13/16-20UNEF | 27,8 | 10 | 31,0 | 19,5 | 28,7 | 31,2 | 21,0 | 28,7 |
| 16 | 17 / 16 | 15/16-20UNEF | 30,8 | 12 | 34,0 | 21,0 | 30,4 | 34,3 | 22,8 | 30,4 |
| 18 | 19 / 18 | 1 1/16-18UNEF | 34,1 | 13 | 35,0 | 20,0 | 32,0 | 38,6 | 25,3 | 32,0 |
| 20 | 21 / 20 | 1 3/16-18UNEF | 37,3 | 15 | 38,0 | 21,5 | 33,6 | 40,8 | 26,1 | 33,6 |
| 22 | 23 / 22 | 1 5/16-18UNEF | 40,5 | 17 | 42,0 | 24,0 | 35,1 | 43,8 | 27,6 | 35,1 |
| 24 | 25 / 24 | 1 7/16-18UNEF | 43,7 | 18 | 45,0 | 25,5 | 36,6 | 46,5 | 29,1 | 36,6 |

TABLE 2

| ENTRY SIZE | ØK MAX | ØZ REF | ØY REF | H ±0,5 | M ±0,5 | J ±0,5 | THESE DIMENSIONS APPLY IF BACKSHELL IS STAINLESS STEEL OR NICKEL ALUMINIUM BRONZE | | |
|------------|--------|--------|--------|--------|--------|--------|---|--------|--------|
| | | | | | | | H ±0,5 | M ±0,5 | J ±0,5 |
| 03 | NA | 4,77 | 13,1 | NA | NA | NA | NA | NA | NA |
| 04 | NA | 6,35 | 13,1 | NA | NA | NA | NA | NA | NA |
| 05 | 21,0 | 7,92 | 13,1 | 24,0 | 15,5 | 25,7 | 24,3 | 17,2 | 25,7 |
| 06 | 21,0 | 9,52 | 17,9 | 24,0 | 15,5 | 25,7 | 24,3 | 17,2 | 25,7 |
| 07 | 21,0 | 11,12 | 17,9 | 24,0 | 15,5 | 25,7 | 24,3 | 17,2 | 25,7 |
| 08 | 24,5 | 12,70 | 17,9 | 27,0 | 17,0 | 27,2 | 28,3 | 19,4 | 27,2 |
| 09 | 24,5 | 14,27 | 17,9 | 27,0 | 17,0 | 27,2 | 28,3 | 19,4 | 27,2 |
| 10 | 29,0 | 15,87 | 24,2 | 31,0 | 19,5 | 28,7 | 31,1 | 21,0 | 28,7 |
| 11 | 32,5 | 17,47 | 24,2 | 34,0 | 21,0 | 30,4 | 34,2 | 22,8 | 30,4 |
| 12 | 32,5 | 19,05 | 24,2 | 34,0 | 21,0 | 30,4 | 34,2 | 22,8 | 30,4 |
| 13 | 35,5 | 20,62 | 24,2 | 35,0 | 20,0 | 32,1 | 38,5 | 25,3 | 32,1 |
| 14 | 35,5 | 22,23 | 30,6 | 35,0 | 20,0 | 32,1 | 38,5 | 25,3 | 32,1 |
| 15 | 37,0 | 23,82 | 30,6 | 38,0 | 21,5 | 33,7 | 40,7 | 26,1 | 33,7 |
| 16 | 37,0 | 25,40 | 30,6 | 38,0 | 21,5 | 33,7 | 40,7 | 26,1 | 33,7 |
| 17 | 40,0 | 26,98 | 33,2 | 42,0 | 24,0 | 35,2 | 43,7 | 27,6 | 35,2 |
| 18 | 40,0 | 28,60 | 33,2 | 42,0 | 24,0 | 35,2 | 43,7 | 27,6 | 35,2 |
| 20 | 43,5 | 31,80 | 42,0 | 45,0 | 25,5 | 36,7 | 46,4 | 29,1 | 36,7 |
| 21 | 48,5 | 33,34 | 42,0 | 54,5 | 31,0 | 39,8 | 50,0 | 31,0 | 39,8 |
| 22 | 48,5 | 35,00 | 42,0 | 54,5 | 31,0 | 39,8 | 50,0 | 31,0 | 39,8 |
| 24 | 52,1 | 38,10 | 42,0 | 58,0 | 33,0 | 43,8 | 53,5 | 33,0 | 43,8 |
| 28 | 58,5 | 44,45 | 49,0 | 65,5 | 36,5 | 48,9 | 60,3 | 36,5 | 48,9 |

| | | | | |
|--|---------------------------|-------------|-----------------|--|
| DRAWN | K.WINCZURA | DATE | 18/02/2015 |  3RD ANGLE PROJECTION NOT TO SCALE |
| CHECKED | | DATE | 18/02/2015 | |
| APPROVED | K.SHEPPARD | DATE | 24/02/2015 | |
| APPROVED | H.SMITH | DATE | 05/10/2015 | |
| REVISIONS | | | | |
| LTR | DESCRIPTION | DATE | APPROVED | |
| M | REVISED PER ECO-15-003780 | 16.03.15 | I.MYONG | |
| N | REVISED PER ECO-15-013980 | 05.10.15 | H.SMITH | |
| TE CAGE CODE: 06090 POLAMCO/TE CAGE CODE: U5792 | | | | |

| | | | |
|--|--|---------------------|----------|
| TITLE: | BRAID TAIL BACKSHELL | | |
| ASSY USED ON: | MIL-DTL-38999 SERIES I & II | | |
| TE CONNECTIVITY - POLAMCO LTD RESERVES THE RIGHT TO AMEND THIS DRAWING AND THE INFORMATION SET FORTH HEREON AT ANY TIME. USERS SHOULD INDEPENDENTLY EVALUATE THE SUITABILITY OF THE PRODUCT FOR THEIR APPLICATION. | | | |
| DRAWING NO: | 204M2XX | DRAWING REV: | N |
| | | SHT | 3 |



Polamco
connectivity