

BY AMP INCORPORATED. ALL RIGHTS RESERVED. AMP PRODUCTS COVERED BY PATENTS AND/OR PATENTS PENDING. APPROVED PER GOVT CONTRACT NO.

REVISIONS				REVISIONS				
SYM	DESCRIPTION	DATE	APP	SYM	ZONE	DESCRIPTION	DATE	APPROVAL
K	REV PER ECO-05-005359	11-14-05	PY/DE	D		RELEASED WAS M5012-295	12-31-64	LAB B.S.H.
L	REV PER ECO 17-015725	CT	3-27-18	PD				
A				A		REVISED W-524 W-421	8-2-5	M.S. RM
B				B		REVISED W-777	10-14-5	M.S. D.H.
C				C		REV. PER D-644	10-6-75	DE
D				D		REV./ECN H-220	8-14-80	DE
E				E		REV PER ECN H-203	5-12-81	DE
F				F		REV PER ECN K-335	7-19-83	DE B.S.H.
G				G		REV. PER ECN R-764	8-27-84	RG J.M.H.
H				H		OBSOLETE -1 PER ECN R-2604	2-23-87	SDG J.B.
J				J		REV PER ECO-05-001412	05/05	AA/AM

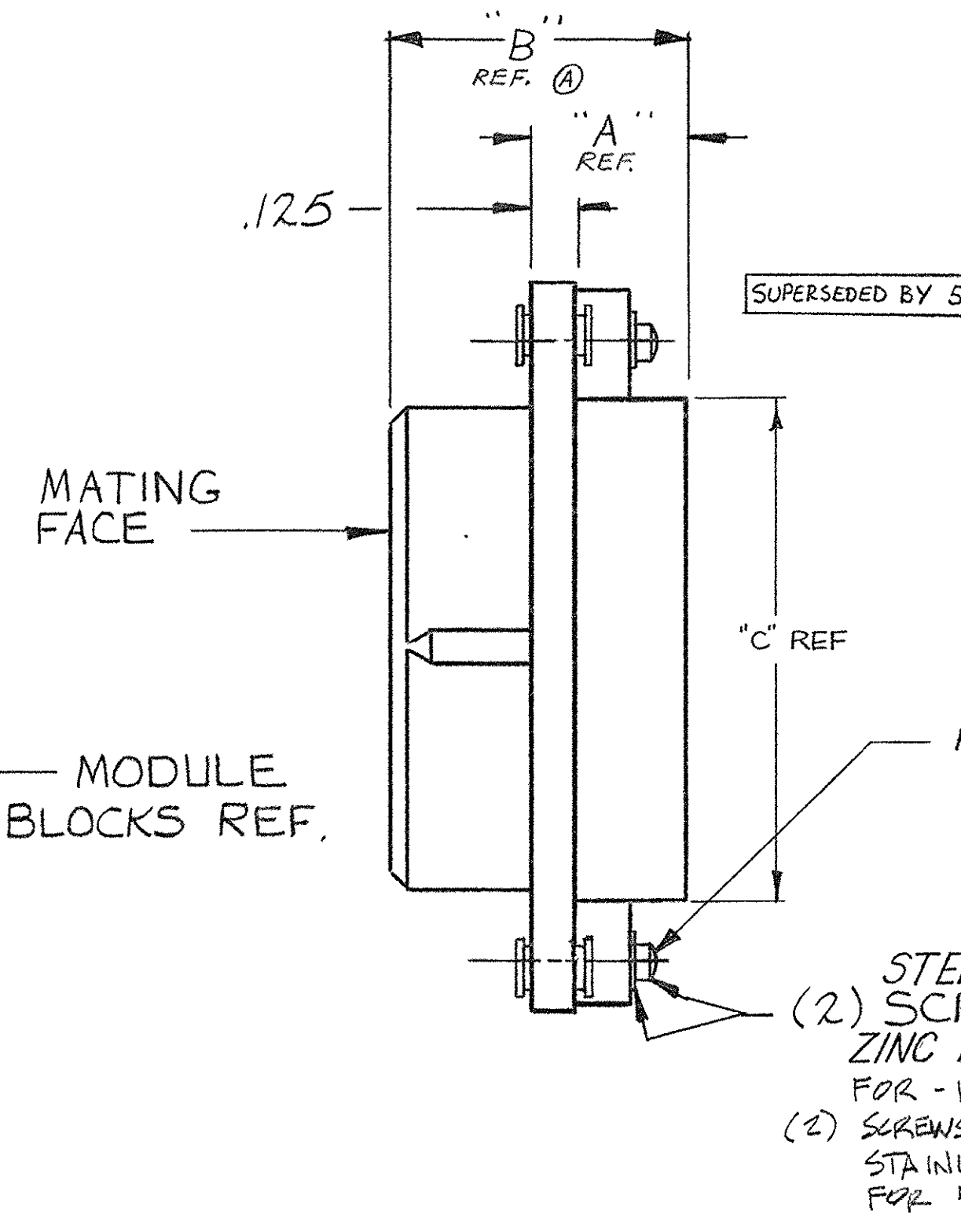
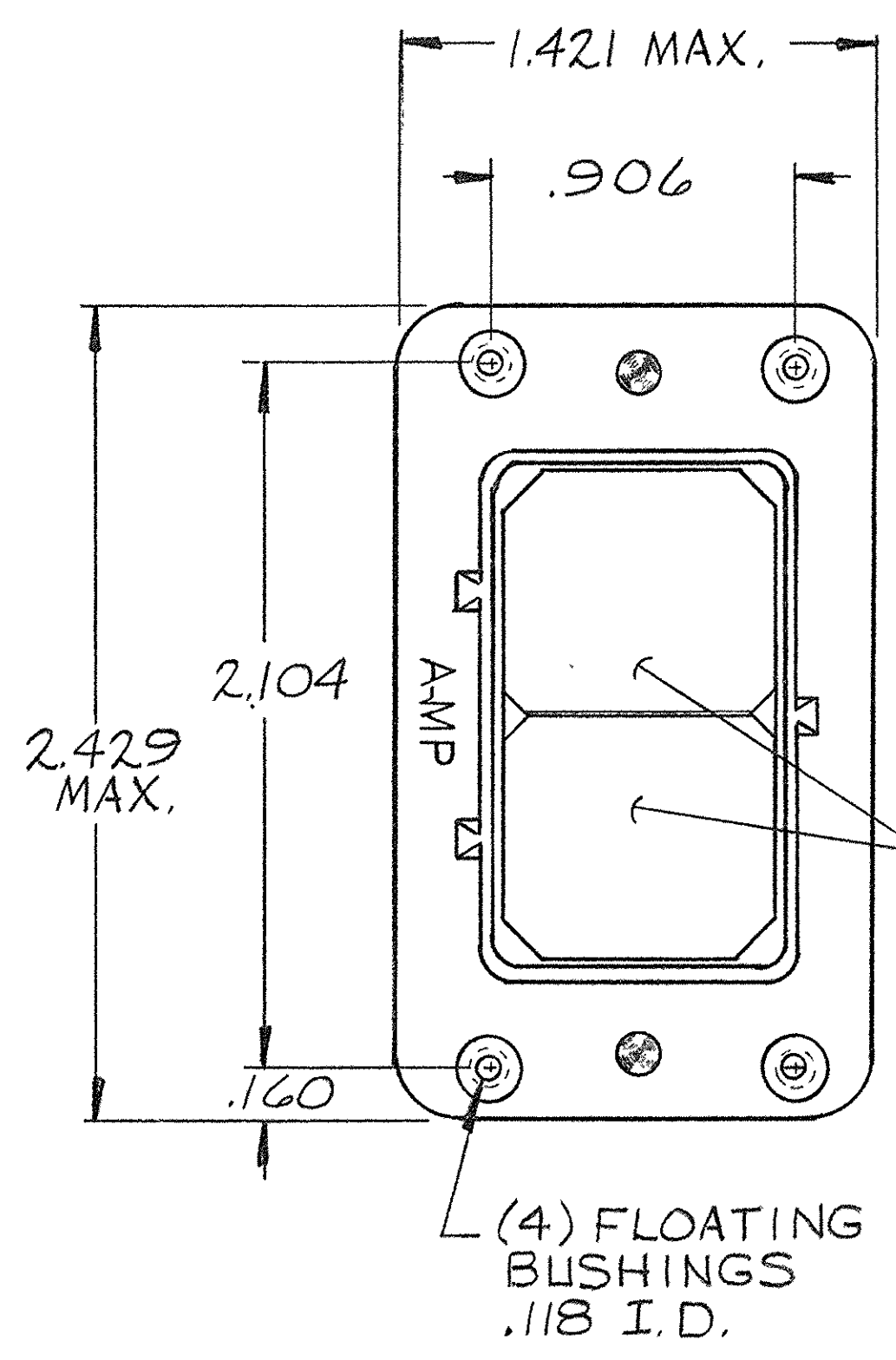

- 202680-1. OBSOLETE
- 202680-2. OBSOLETE
- 202680-3. 1. SAME AS -2 EXCEPT: 2. "A" AND "B" DIMENSIONS.
- 202680-4. OBSOLETE
- 5-202680-3. 1. SAME AS -3 EXCEPT: 2. PLATING

SUPERSEDED BY 5--3

MATING FACE

MODULE BLOCKS REF.

FILLISTER HEAD SCREWS

(2) STEEL SCREWS, ZINC PLATED FOR -1, -2, -3 & -4.
(2) SCREWS PASSIVATED STAINLESS STEEL FOR 5-3.

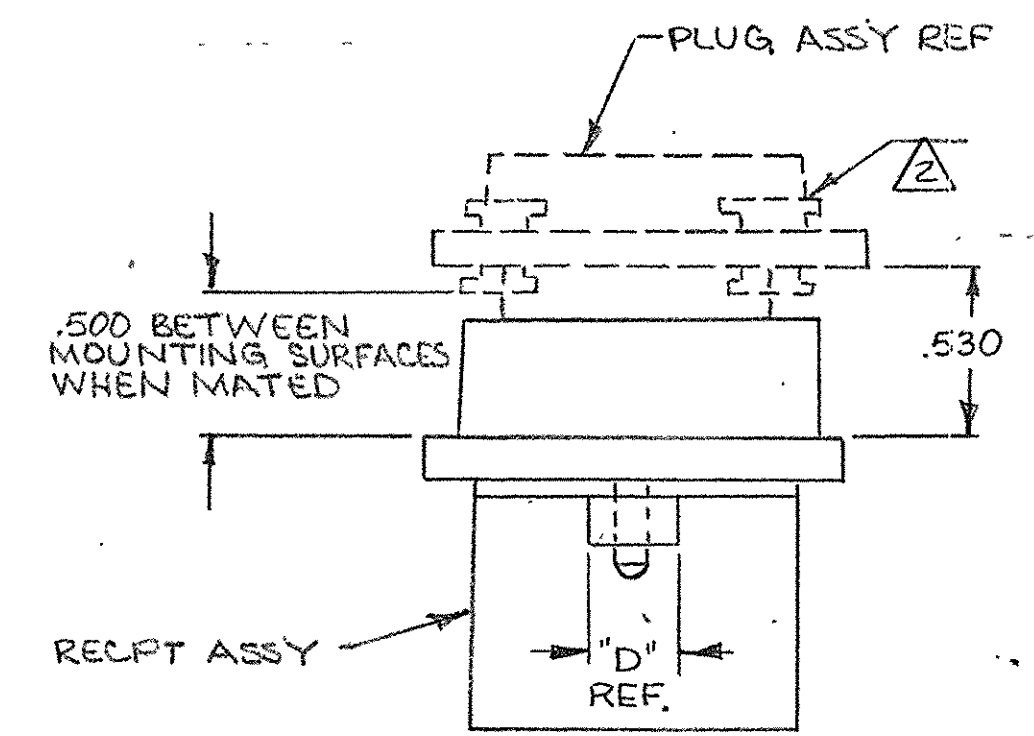

- NOTE:
- ZINC PLATE PER ASTM-B-633 TYPE II, CLASS 3 COLORLESS SUPPLEMENTARY CHROMATE
 - THE ALLOWABLE FLOAT IS .063 TO .075
 - PLATING ELECTROLESS NICKEL PER SAE-AMS-C-26074 .000400 - .000300 THK (NO INTENTIONAL ADDITIONS OF LEAD OR CADMIUM PER DFE STD 230-700).

OBSOLETE	202680-4	.480	1.010	1.569	.126	△
SUPERSEDED BY 5-202680-3		.886	1.416	1.650	.150	△
OBSOLETE	202680-2	.480	1.010	1.650	.150	△
	202680-1	.480	1.010	1.650	.150	△

AMP INFO		NOMENCLATURE OR DESCRIPTION		PART OR IDENTIFYING NO		A		B		C		D		FINISH	
LOC	PRINT DIST	QTY	REQD	R 39 J		A		B		C		D		FINISH	
UNLESS OTHERWISE SPECIFIED DIMENSIONS ARE IN INCHES TOLERANCES ON FRACTIONS DECIMALS ANGLES ± .005 ±				SIGNATURE		DATE		AMP INCORPORATED HARRISBURG, PENNSYLVANIA							
MATERIAL				DR		DATE		PLUG ASSEMBLY MODULE							
DIE CAST ALUMINUM				CHK		DATE									
HEAT TREAT				DSGN ENGR		DATE									
FINISH				APPD		DATE									
SEE NOTE 1				DSGN APPD		CODE IDENT NO		SIZE		NUMBER		REV		L	
				OTHER APPD		SCALE		WT		CALC		ACTUAL		SHEET	