

THIS DRAWING IS UNPUBLISHED. RELEASED FOR PUBLICATION 2016
 © COPYRIGHT 2008 BY - TE Connectivity ALL RIGHTS RESERVED.

REVISIONS					
P	LTR	DESCRIPTION	DATE	DWN	APVD
	A1	REVISED (ECR-09-024685)	11. NOV. '09	KT	HG
	B	REVISED (ECR-15-014757)	12. NOV. '15	SJ	HG
	B1	REVISED (ECR-16-007341)	20. MAY. '16	SJ	JW
	C	REVISED (ECR-16-008800)	17. JUN. '16	JM	JW

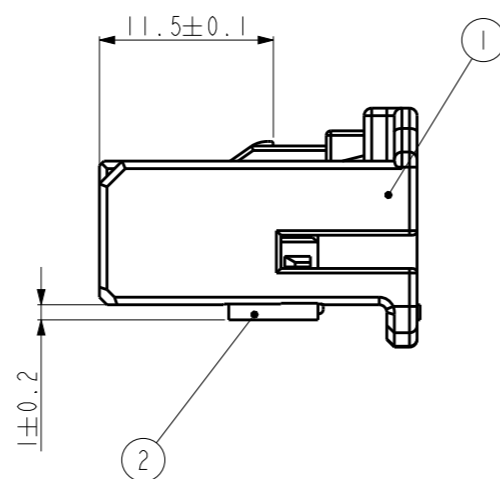
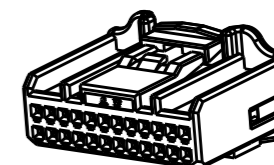
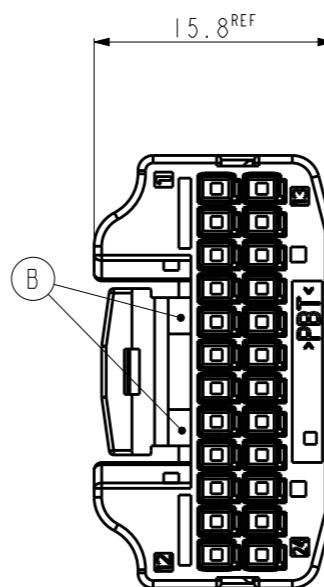
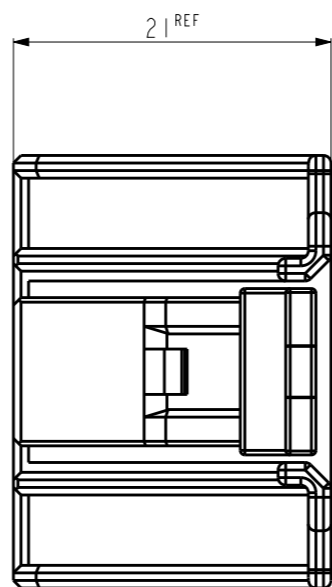
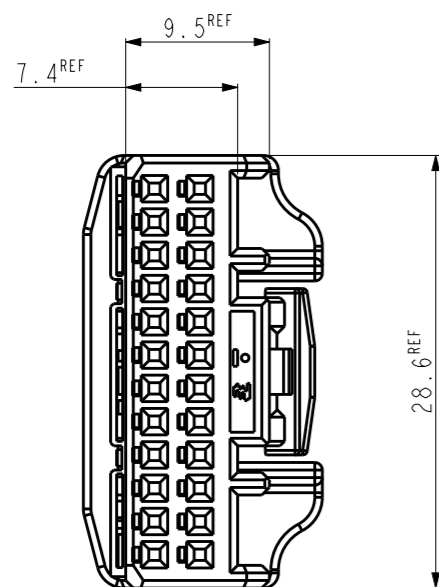

- NOTE
- PART NUMBER OF CAP HOUSING TO BE MATED : 2005085
 - APPLIED TERMINAL : SEE TABLE 1
 - GENERAL TOLERANCE : ±0.3, ±3°

NO.	COLOR	MATERIAL	DESCRIPTION	Q'TY	
2	NATURAL	PBT	DBL HSG	1	1
1	BLACK	PBT	PLUG HSG	1	
	NATURAL	PBT	PLUG HSG		1

PLUG ASS'Y	PLUG ASS'Y	DESCRIPTION
2005082-2	2005082-1	ASS'T P/N

<TABLE 1>

P/NO	FINISH	WIRE RANGE
2005097-1	PRE-TIN	0.13 ~ 0.22
2005427-1	PRE-TIN	0.3 ~ 0.5

THIS DRAWING IS A CONTROLLED DOCUMENT.

DIMENSIONS: mm	TOLERANCES UNLESS OTHERWISE SPECIFIED:
	0 PLC ±
	1 PLC ±
	2 PLC ±
	3 PLC ±
	4 PLC ±
	ANGLES ±
MATERIAL SEE TABLE	FINISH -

DWN JM JEON	TE TE Connectivity			
CHK -				
APVD JW JUNG	NAME 025 24P PLUG ASS'Y			
PRODUCT SPEC -	SIZE A3	CAGE CODE 00779	DRAWING NO C-2005082	RESTRICTED TO -
APPLICATION SPEC -	CUSTOMER DRAWING		SCALE 2:1	SHEET 1
WEIGHT -			OF 1	REV C