

THIS DRAWING IS UNPUBLISHED. RELEASED FOR PUBLICATION  
 © COPYRIGHT BY TYCO ELECTRONICS CORPORATION. ALL INTERNATIONAL RIGHTS RESERVED.

| LOC | DIST | REVISIONS   |         |     |      |  |
|-----|------|-------------|---------|-----|------|--|
| P   | LTR  | DESCRIPTION | DATE    | DWN | APVD |  |
| FT  | 0    |             |         |     |      |  |
|     | 1    | DRAWN       | 24JUN10 | JR  | CR   |  |

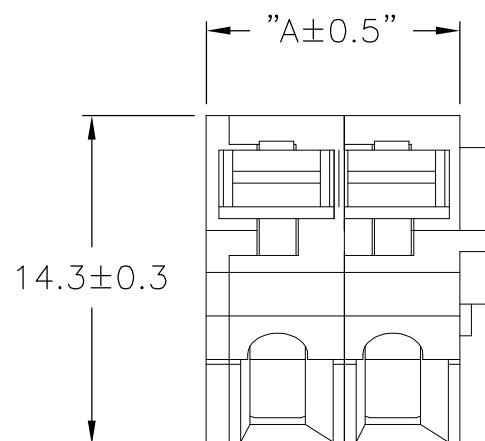

**NOTES:**

**MATERIAL:**

HOUSING: POLYAMIDE 66, UL94V-0, GRAY.  
 LEVER: GRILON AG30  
 COVER: POLYAMIDE 66, UL94V-0, GRAY.  
 TERMINAL: BRASS, TIN PLATED.  
 SPRING: STAINLESS STEEL.

**ELECTRICAL:**

VOLTAGE RATING: 300VAC.  
 CURRENT RATING: 16A.  
 INSULATION WITHSTANDING: 2000VAC/ 1 MIN.  
 INSULATION RESISTANCE: 2000Mohm/500VDC.  
 WIRE RANGE: 14-28 AWG.

**MECHANICAL:**

OPERATING TEMP.: -40°C TO +105°C

**1** PRELIMINARY PART NUMBER.

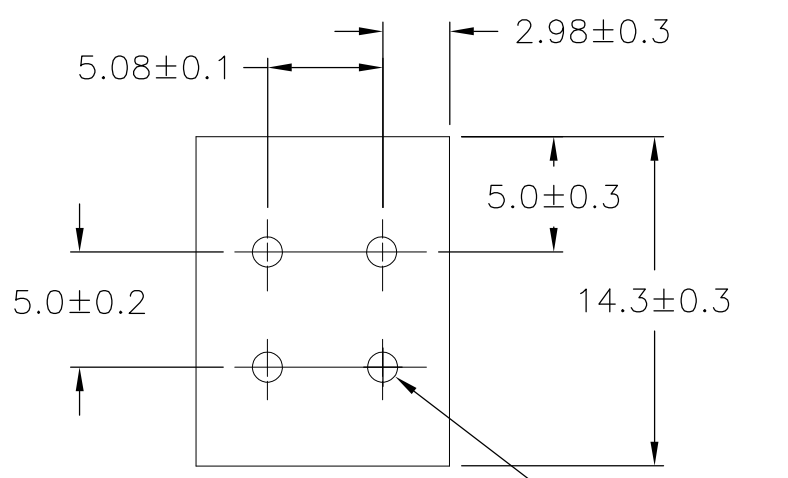
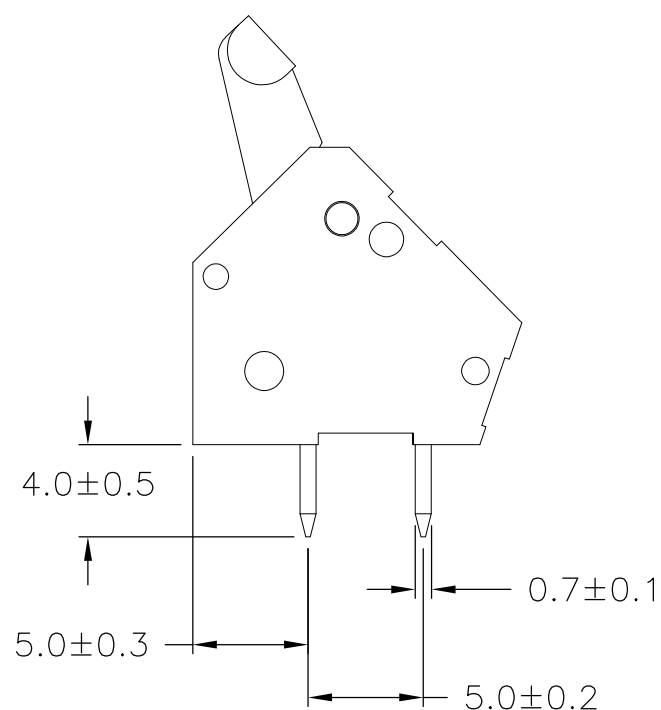
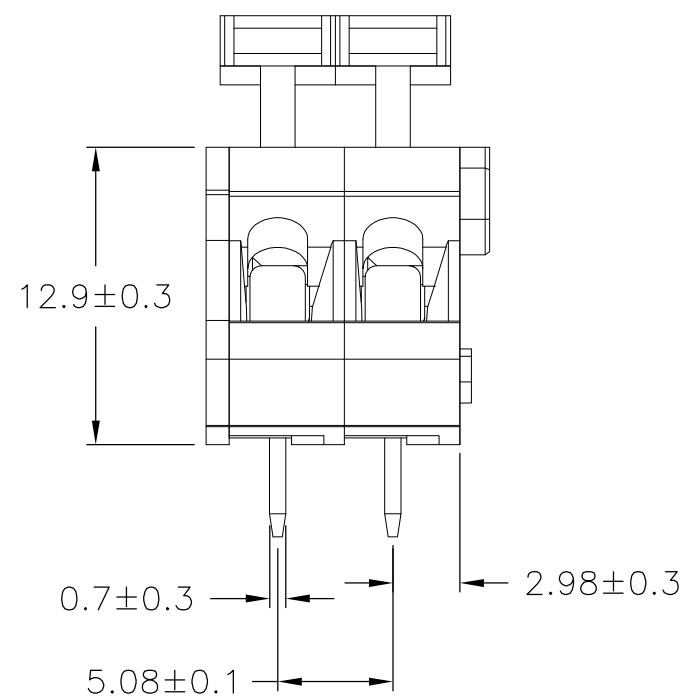

**PCB Layout**

1.3 DIA TYP

|       |            |                    |
|-------|------------|--------------------|
| 11.16 | 2          | <b>1</b> 1986651-2 |
| DIM A | NO OF POSN | PART NUMBER        |

|  |  |                        |   |                 |
|--|--|------------------------|---|-----------------|
| THIS DRAWING IS A CONTROLLED DOCUMENT. |  | DWN JR RUTH 23JUN10    | Tyco Electronics Corporation<br>Harrisburg, PA 17105-3608 |                 |
| DIMENSIONS: mm                         |  | CHK C RICHARD 24JUN10  |   |                 |
| TOLERANCES UNLESS OTHERWISE SPECIFIED: |  | APVD C RICHARD 24JUN10 | NAME  |                 |
| 0 PLC ± -                              |  | PRODUCT SPEC           | TERMINAL BLOCK, VERTICAL SCREWLESS W/LEVER                |                 |
| 1 PLC ± 0.3                            |  | APPLICATION SPEC       | 5.08mm  |                 |
| 2 PLC ± 0.25                           |  | WEIGHT -               | SIZE A3   | CAGE CODE 00779 |
| 3 PLC ± -                              |  | CUSTOMER DRAWING       | DRAWING NO C-1986651                                      | RESTRICTED TO - |
| 4 PLC ± -                              |  |                        | SCALE NTS   | SHEET 1 OF 1    |
| ANGLES ± 1°                            |  |                        |   | REV 1           |
| MATERIAL -                             |  |                        |   |                 |
| FINISH -                               |  |                        |   |                 |