

THIS DRAWING IS UNPUBLISHED. RELEASED FOR PUBLICATION
 © COPYRIGHT - By - ALL RIGHTS RESERVED.

LOC	DIST	REVISIONS				
		P	LTR	DESCRIPTION	DATE	DWN
-	-	A2	ECR-11-008821	28/4/11	NH	KR
-	-	A3	ECR-11-014114	07/07/11	SS	KR

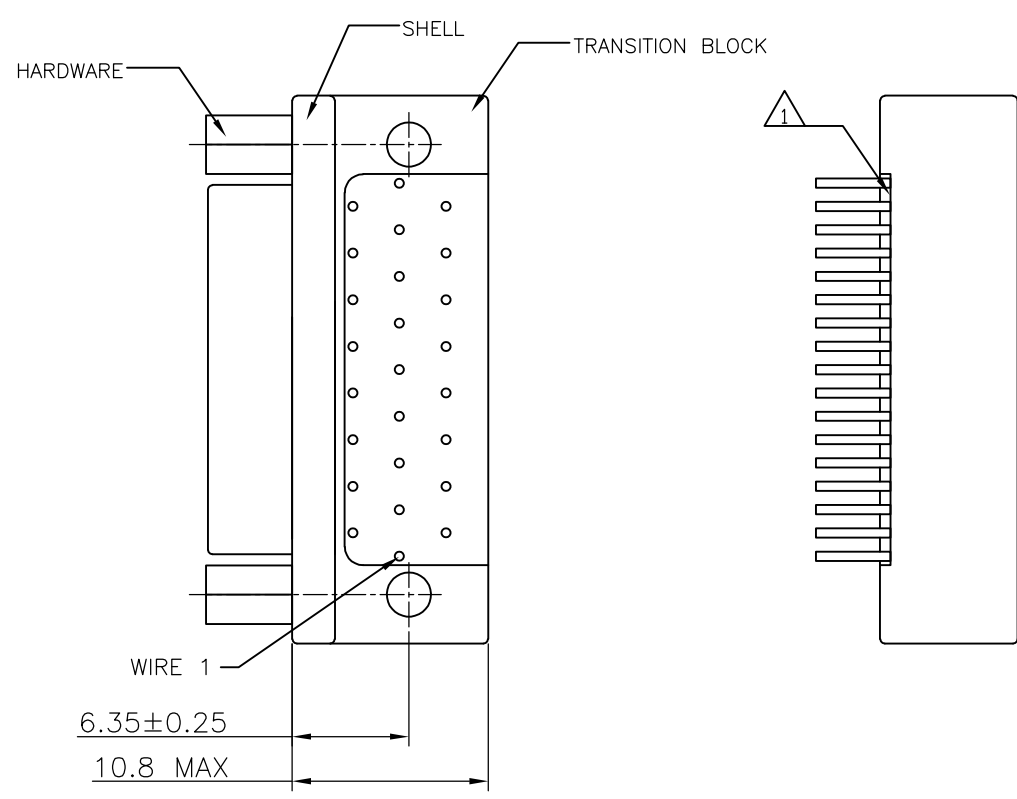
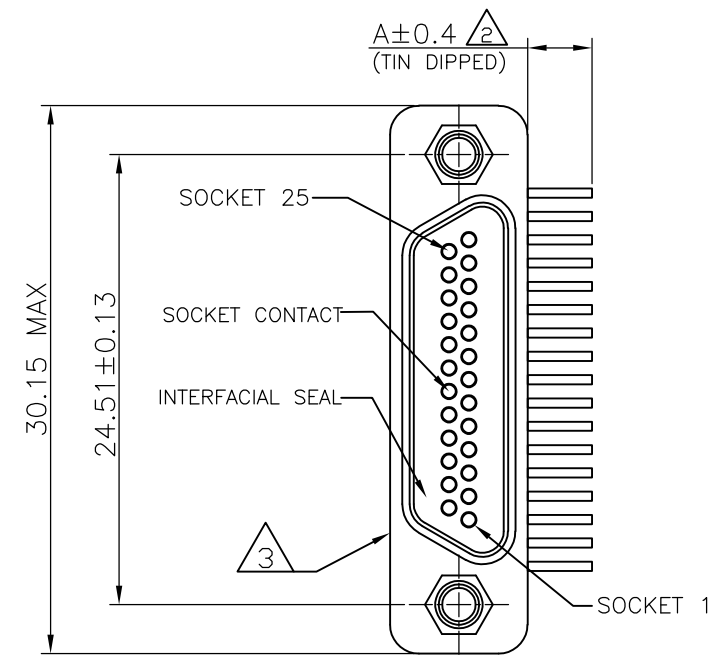
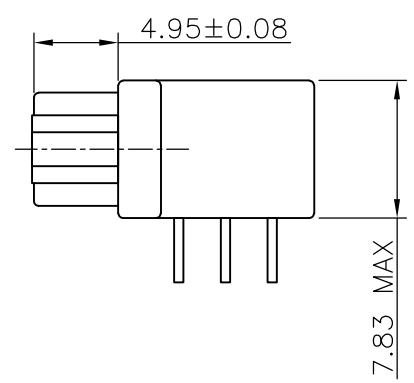

- 1 POTTING LEVEL UP TO HEIGHT AS SHOWN
 - 2 WIRES CROPPED TO LENGTH AS SHOWN.
 - 3 INMARK TE PN AND DATE CODE YYWW ON CONNECTOR SHELL.
- 4 SPECIFICATION:
- a. ELECTRICAL:
 - CONTACT RESISTANCE :25 MILLIVOLTS MAX. AT 3 AMPS
 - INSULATION RESISTANCE :5000 MEGAOHMS MIN. @ 500 VDC AT AMBIENT ROOM TEMPERATURE
 - CURRENT RATING :3 AMP MAX. PER CONTACT
 - b. MECHANICAL:
 - CONTACT ENGAGING FORCE :2.22 N MAX. PER CONTACT
 - CONTACT SEPARATION FORCE :0.14 N MIN. PER CONTACT
 - c. ENVIRONMENTAL:
 - OPERATING TEMPERATURE :-55° C TO +125° C
 - VIBRATION CHARACTERISTICS :PER MIL-STD-1344, METHOD 2005, TEST CONDITION IV
- 5 MATERIAL:
 - SHELL :ALUMINIUM ALLOY 6061 T6 GRADE.
 - CONTACT :COPPER ALLOY.
 - BUSHING :STAINLESS STEEL, TYPE 303, PER ASTM-A-582, CONDITION A.
 - HEX NUT :STAINLESS STEEL 300 SERIES NON-MAGNETIC
 - 6 FINISH:
 - SHELL :ELECTROLESS NICKEL PLATING PER AMS2404, 25-30 MICRONS THICK.
 - CONTACTS :GOLD PLATED PER MIL-G-45204, TYPE II, CLASS 1.
 - CONTACT TAIL :TIN DIPPED.
 - BUSHING :PASSIVATE PER QQ-P-35
 - HEX NUT :PASSIVATED
7. DUST CAP NOT SHOWN

VIEWS ARE OF THE TOP SURFACE OF PCB FOR RECEPTACLE CONNECTOR (PHANTOM LINES DEPICT THE OUTLINE OF CONNECTOR ON PCB)

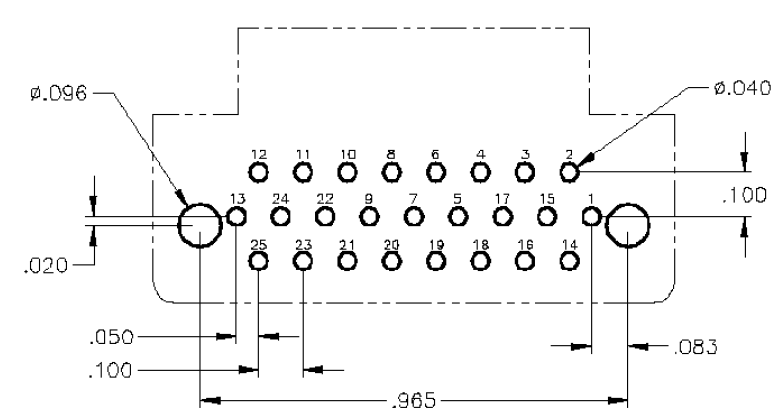

(ABOVE DIMENSIONS ARE IN INCHES)

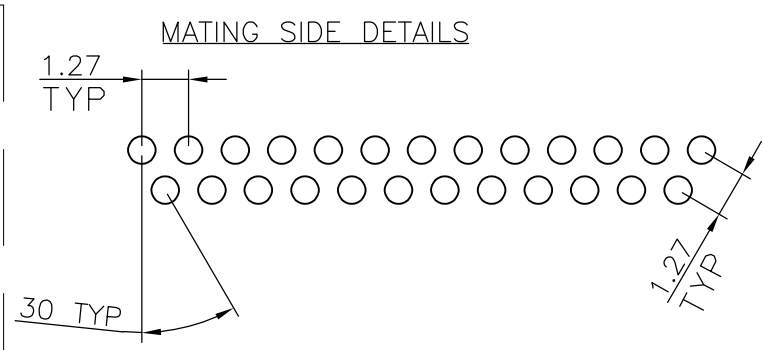

4.37	1959172-3	MCK-N1-P-25SRT1B
2.77	1959172-2	MCK-N1-P-25SRT1
3.56	1959172-1	MCK-N1-P-25SRT1A
A	TE PN	DESCRIPTION

THIS DRAWING IS A CONTROLLED DOCUMENT.		DWN 31JAN2008 NIRANJAN HEGDE	TE Connectivity	
DIMENSIONS: mm [INCHES]		CHK 31JAN2008 SHIVAPRAKASH K R		
TOLERANCES UNLESS OTHERWISE SPECIFIED:		APVD 31JAN2008 KARTHIK S	NAME	
0 PLC ± -		METAL SHELL - 25 SOCKET		
1 PLC ± -		90 DEGREE PCB MOUNT		
2 PLC ± -		-		
3 PLC ± -		APPLICATION SPEC		
4 PLC ± -		-		
ANGLES ± -		SIZE CAGE CODE DRAWING NO RESTRICTED TO		
FINISH		A3 00779 C-1959172		
MATERIAL		CUSTOMER DRAWING SCALE NTS SHEET 1 OF 1 REV A3		