

THIS DRAWING IS UNPUBLISHED. RELEASED FOR PUBLICATION
 © COPYRIGHT - By - ALL RIGHTS RESERVED.

REVISIONS					
P	LTR	DESCRIPTION	DATE	DWN	APVD
A		REVISED PER ECO-12-002687	10FEB12	KH	DR
A1		REVISED PER ECO-18-015553	04OCT2018	RS	DR

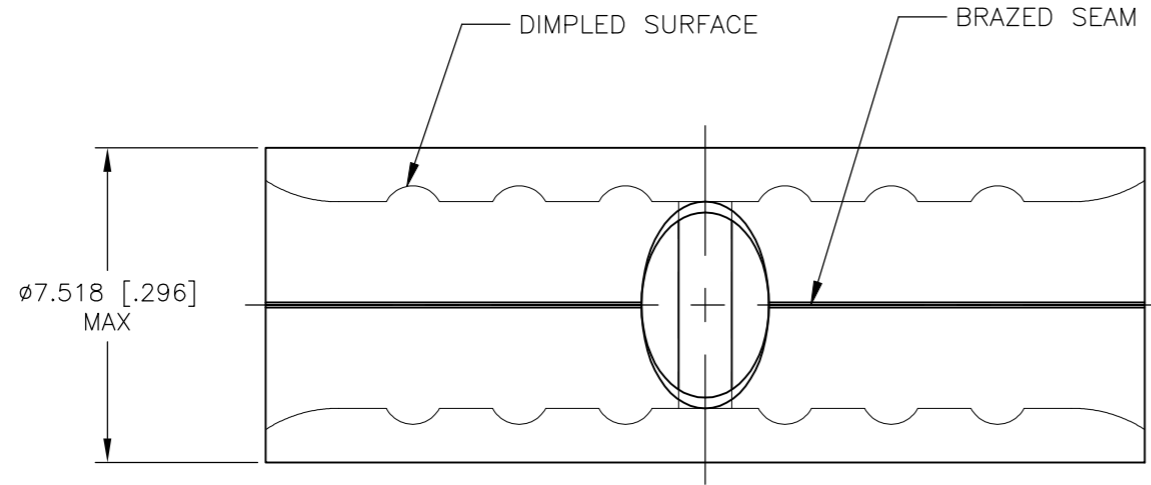

AMP
WIRE RANGE

8 AWG
SOLID OR STRANDED

- 1 STAMP AMP 8W* APPROX AS SHOWN
- 2 MAXIMUM LENGTH DOES NOT INCLUDE MANUFACTURING TABS
- 3 COPPER PER ASTM B-152, ANNEALED
- 4 NICKEL PLATE 0.00762 [0.000300] MIN EXT THK PER SAE AMS QQ-N-290
- 5 NOTE DELETED.

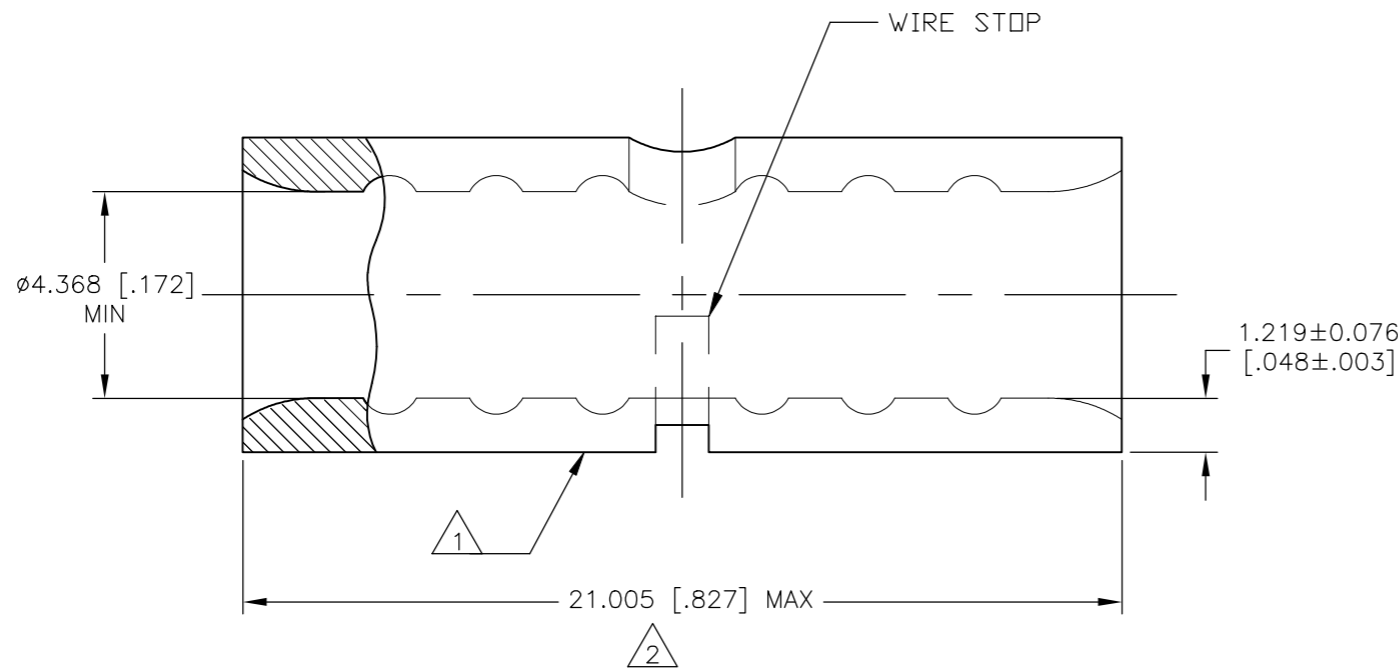

100	LOOSE PIECE	1958317-1
QTY	PACKAGING TYPE	PART NO.

MAX RECOMMENDED OPERATING TEMPERATURE: 343°C [649°F] MAX	THIS DRAWING IS A CONTROLLED DOCUMENT.		DWN JR RUTH 29AUG09	STE TE Connectivity Ltd.
	VOLTAGE RATING: N/A	DIMENSIONS: MM [INCHES]	CHK TOM MICHELUTTI 31AUG09	
CIRCULAR MIL AREA: 6.64-10.5mm ² [13,100-20,800] SOLID OR STRANDED	MATERIAL - 3	TOLERANCES UNLESS OTHERWISE SPECIFIED: 0 PLC ± - 1 PLC ± - 2 PLC ± - 3 PLC ± 0.127 [0.005] 4 PLC ± - ANGLES ± -	FINISH - 4	NAME TOM MICHELUTTI
				PRODUCT SPEC APPLICATION SPEC 114-2162
				SIZE A2
				CAGE CODE 00779
				DRAWING NO C-1958317
				RESTRICTED TO -
				SCALE 8:1
				SHEET 1 OF 1
				REV A1