

THIS DRAWING IS UNPUBLISHED. RELEASED FOR PUBLICATION
 © COPYRIGHT - By - ALL RIGHTS RESERVED.

LOC		DIST		REVISIONS			
P	LTR	DESCRIPTION		DATE	DWN	APVD	
	B	UPDATE PER ECO-11-013272		28 JUN 11	CAS	MKS	

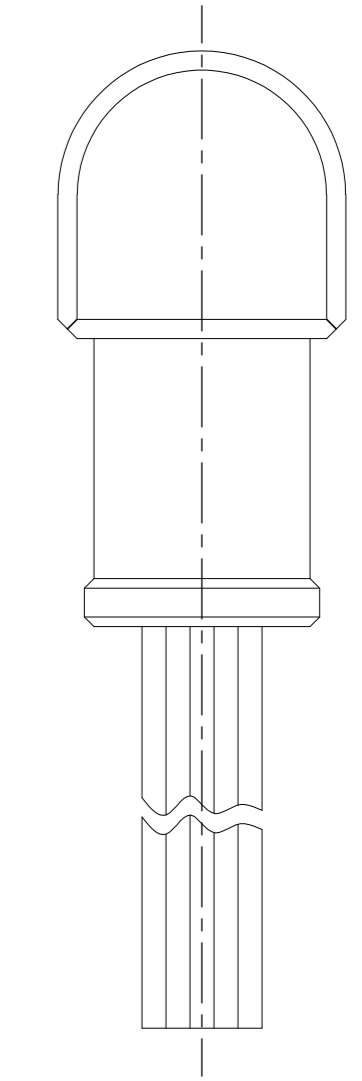
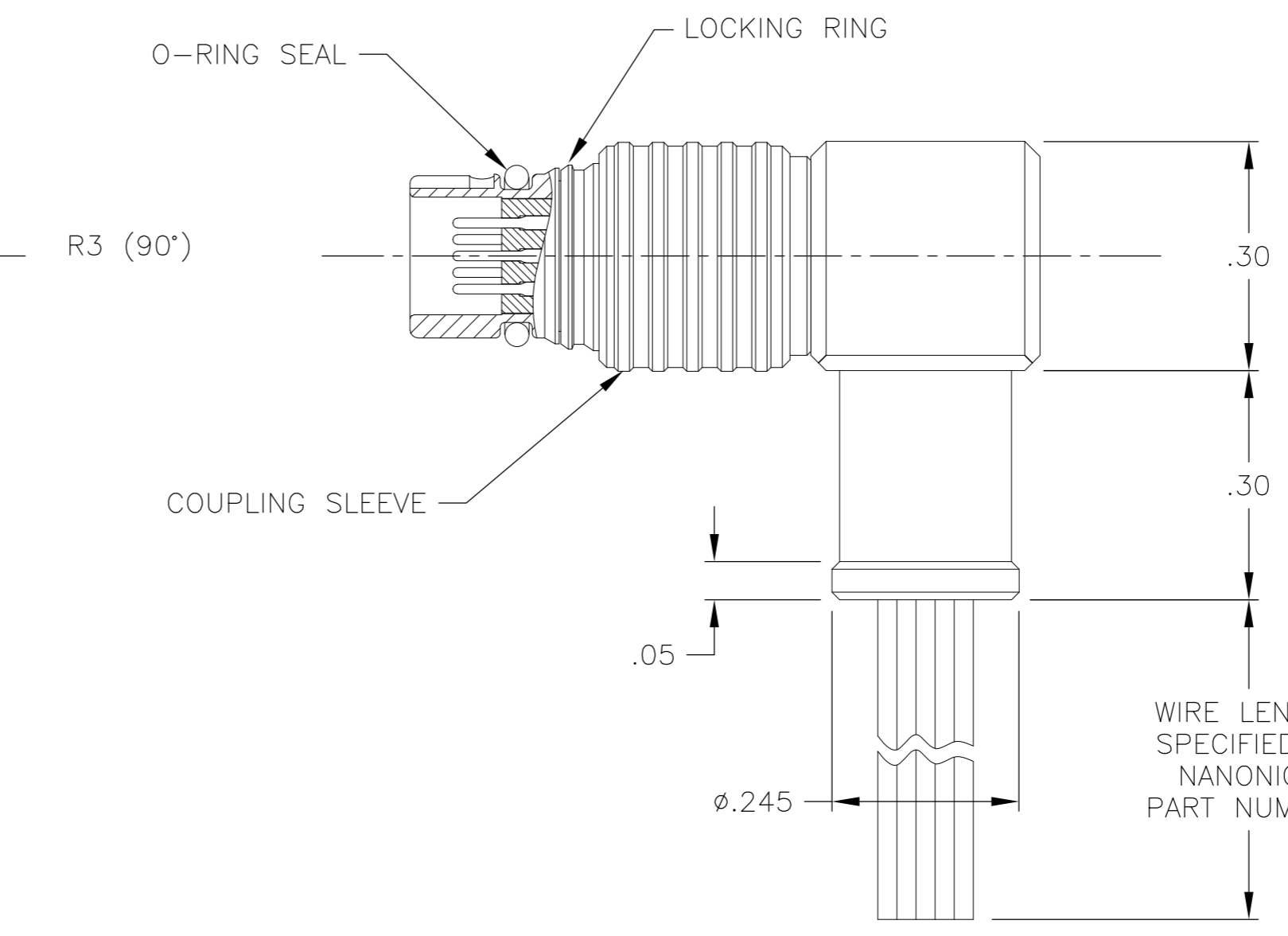
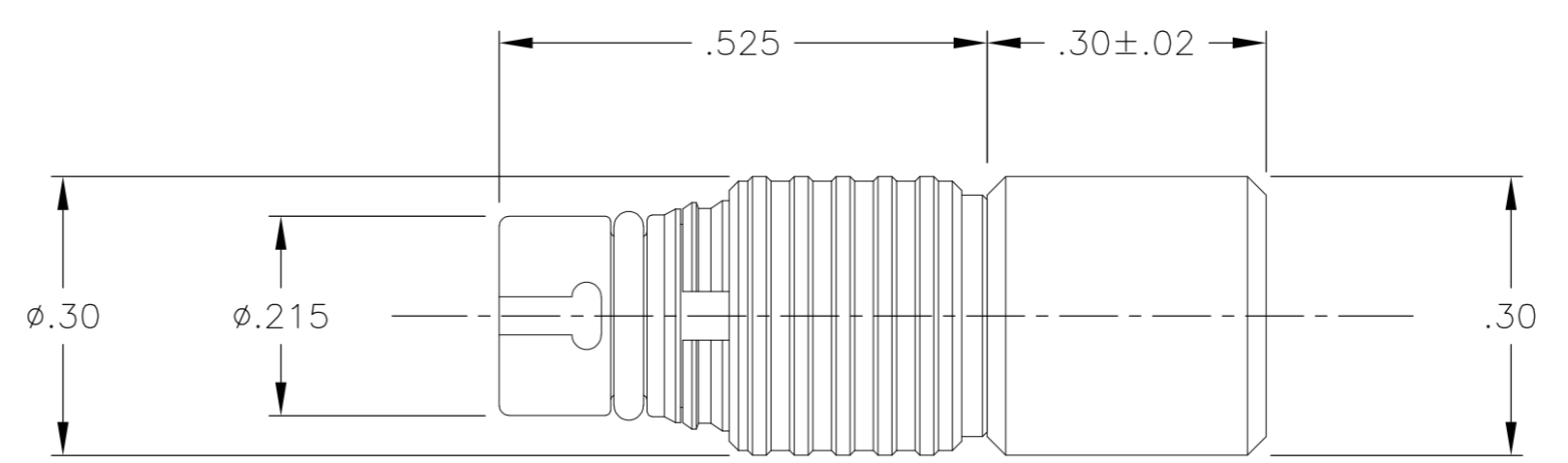
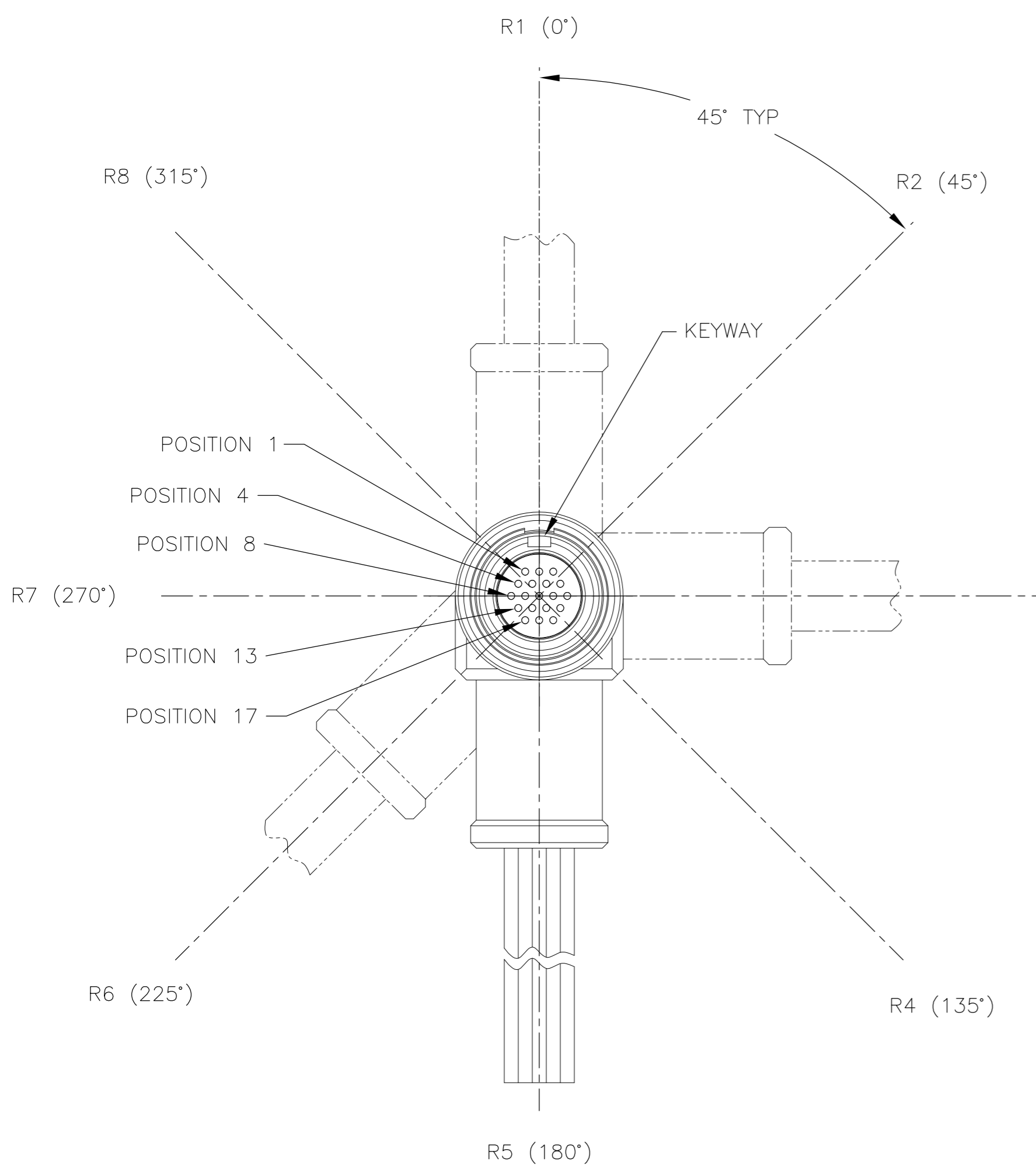

- CONNECTOR BODY, COUPLING SLEEVE & BACKSHELL MATERIAL: 6061-T6 ALUMINUM, ELECTROLESS NICKEL PLATE PER SAE-AMS-C-26074 OR AMS 2404E
 LOCKING RING MATERIAL: BERYLLIUM COPPER, ELECTROLESS NICKEL PLATE PER SAE-AMS-C-26074 OR AMS 2404E
 INSULATOR MATERIAL: LIQUID CRYSTAL POLYMER (LCP) PER ASTM D5138 OR POLYPHENYLENE SULFIDE (PPS) PER ASTM D4067
 O-RING MATERIAL: FLUOROSILICONE
- WIRE TERMINATION: 28AWG SOLID, 30AWG STRANDED WIRE OR SMALLER.
- BONDING RESISTANCE BETWEEN CONNECTOR BODY AND BACKSHELL TO BE 25 MILLIOHMS MAXIMUM. BACKSHELL TO BE BONDED TO PLUG SHELL WITH CONDUCTIVE EPOXY.
- LUBRICATE O-RING WITH PARKER SUPER-O-LUBE PRIOR TO INSTALLATION
- BACKSHELL MAY BE ORIENTED IN THE EIGHT DIRECTIONS SHOWN (R1 THRU R8). POSITION R5 IS CONSIDERED STANDARD. THE BACKSHELL CODE AT THE END OF THE NANONICS PART NUMBER SHALL INDICATE BACKSHELL ORIENTATION.
- THIS DRAWING ALSO IDENTIFIED AS NANONICS 303-0135

THIS DRAWING IS A CONTROLLED DOCUMENT.		DWN D. MORALES 23OCT08		
DIMENSIONS: INCHES		CHK M. STORRY 23OCT08		
TOLERANCES UNLESS OTHERWISE SPECIFIED:		APVD -	NAME	
0 PLC ± - 1 PLC ± - 2 PLC ± .010 3 PLC ± .005 4 PLC ± - ANGLES ± 10°		PRODUCT SPEC -	PLUG ASSEMBLY, CIRCULAR, QUICK DISCONNECT COUPLING, METAL, 19 POSITION W/ 90 DEGREE BACKSHELL	
MATERIAL SEE NOTES		FINISH SEE NOTES	WEIGHT -	RESTRICTED TO -
CUSTOMER DRAWING		SCALE 5:1	SHEET 1 of 1	REV B