

| LOC | DIST | REVISIONS | | | | | |
|-----|------|-----------|-----|------------------|-----------|-----|------|
| GP | 00 | P | LTR | DESCRIPTION | DATE | DWN | APVD |
| | | I | | PROPOSAL DRAWING | 15FEB2012 | OL | SZ |
| | | A | | FIRST RELEASE | 20FEB2012 | OL | SZ |

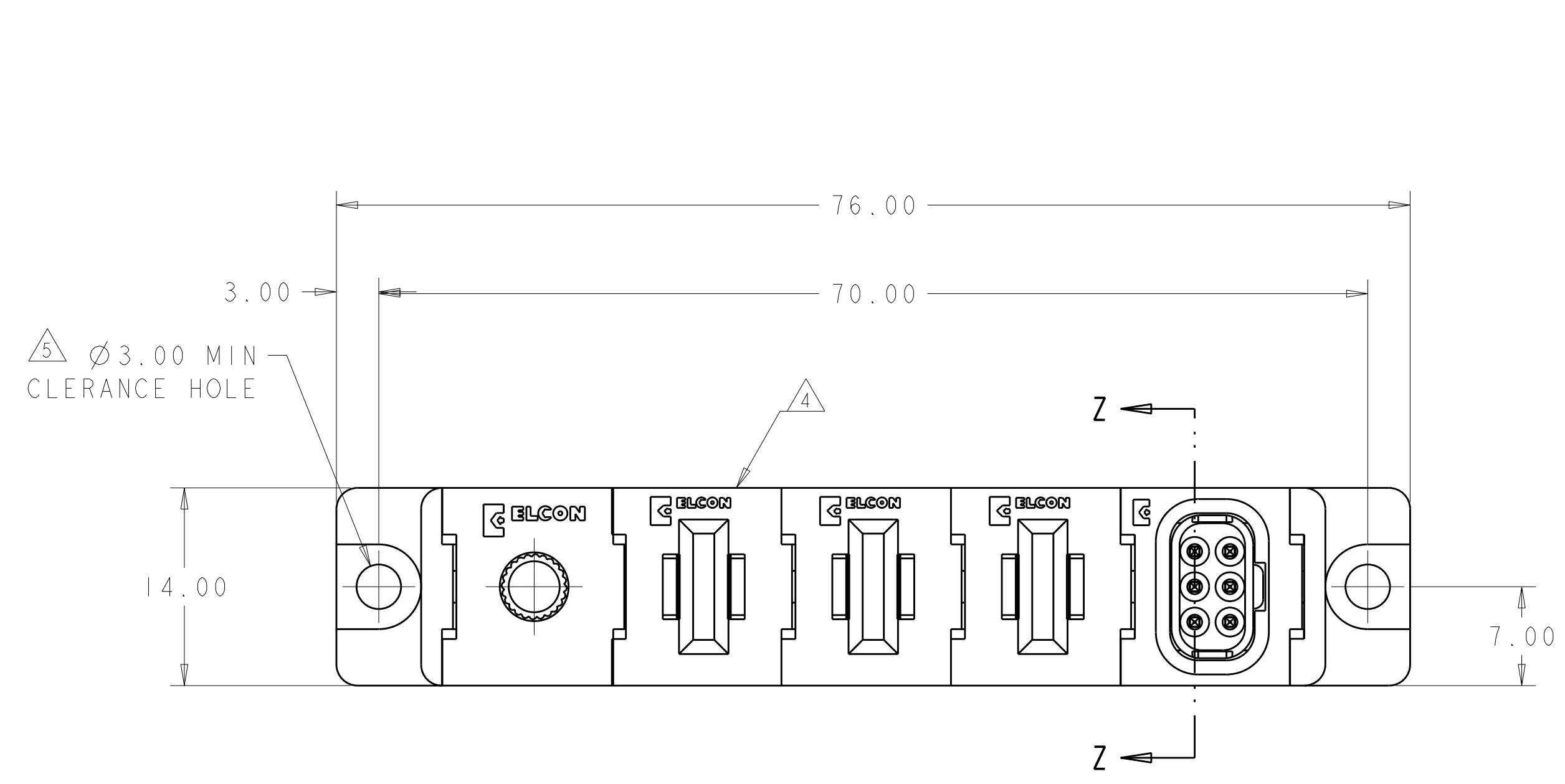

1. PART NUMBER CHANGES AND OR DESIGN CHANGES AFFECTING ITEM INTERCHANGEABILITY REQUIRE PRIOR TYCO ELECTRONICS APPROVAL AND AUTHORIZATION BY REVISION TO THIS DRAWING.
2. MATERIAL:
 INSULATORS - THERMOPLASTIC, GLASS REINFORCED, COLOR: BLACK
 UL94V-0 FLAMMABILITY RATED.
 POWER CONTACTS - PHOSPHOR BRONZE ALLOY,
 COPPER ALLOY
 SOLDER SIGNAL PIN - BRASS ALLOY
 CROWN BAND-BERYLLIUM COPPER ALLOY
 GUIDE PIN-BRASS ALLOY
3. FINISH:
 CONTACTS - GOLD PLATE 0.76µm MIN. THK., OVER
 NICKEL 1.27µm MIN. THK
 SOLDER TAILS, TIN 3.05µm MIN. THK.
 OVER NICKEL 1.27µm MIN. THK
 GUIDE PIN - NICKEL PLATE 1.27µm MIN THK.
4. ITEMS PROVIDED TO THIS SPECIFICATION TO BE PERMANENTLY IDENTIFIED PER THE FOLLOWING IDENTIFIER LABEL
- YEAR WEEK
- TYCO ELECTRONICS P/N DATE CODE (e.g. 0106)
 XXXXXXXX-X XXXX
5. MOUNTING FLANGES ACCEPT M3 OR 4-40 SCREWS (USER SUPPLIED).

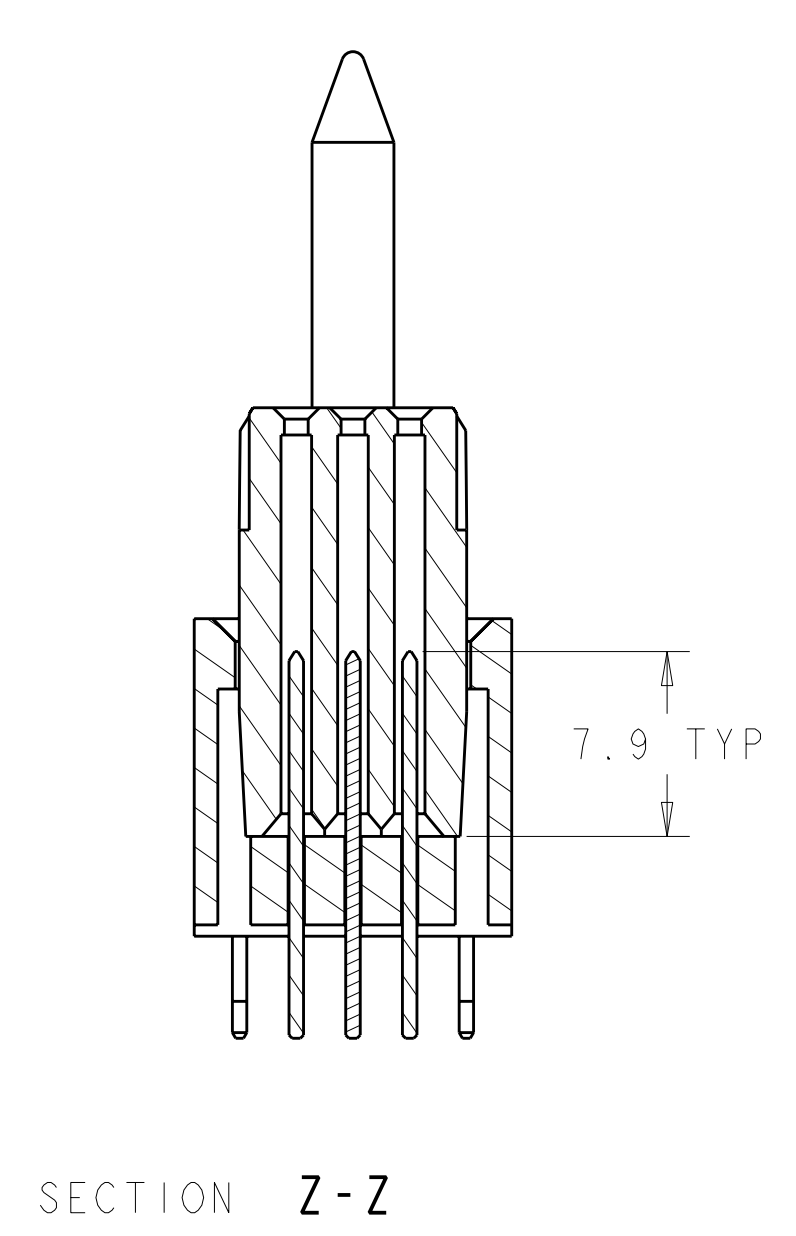
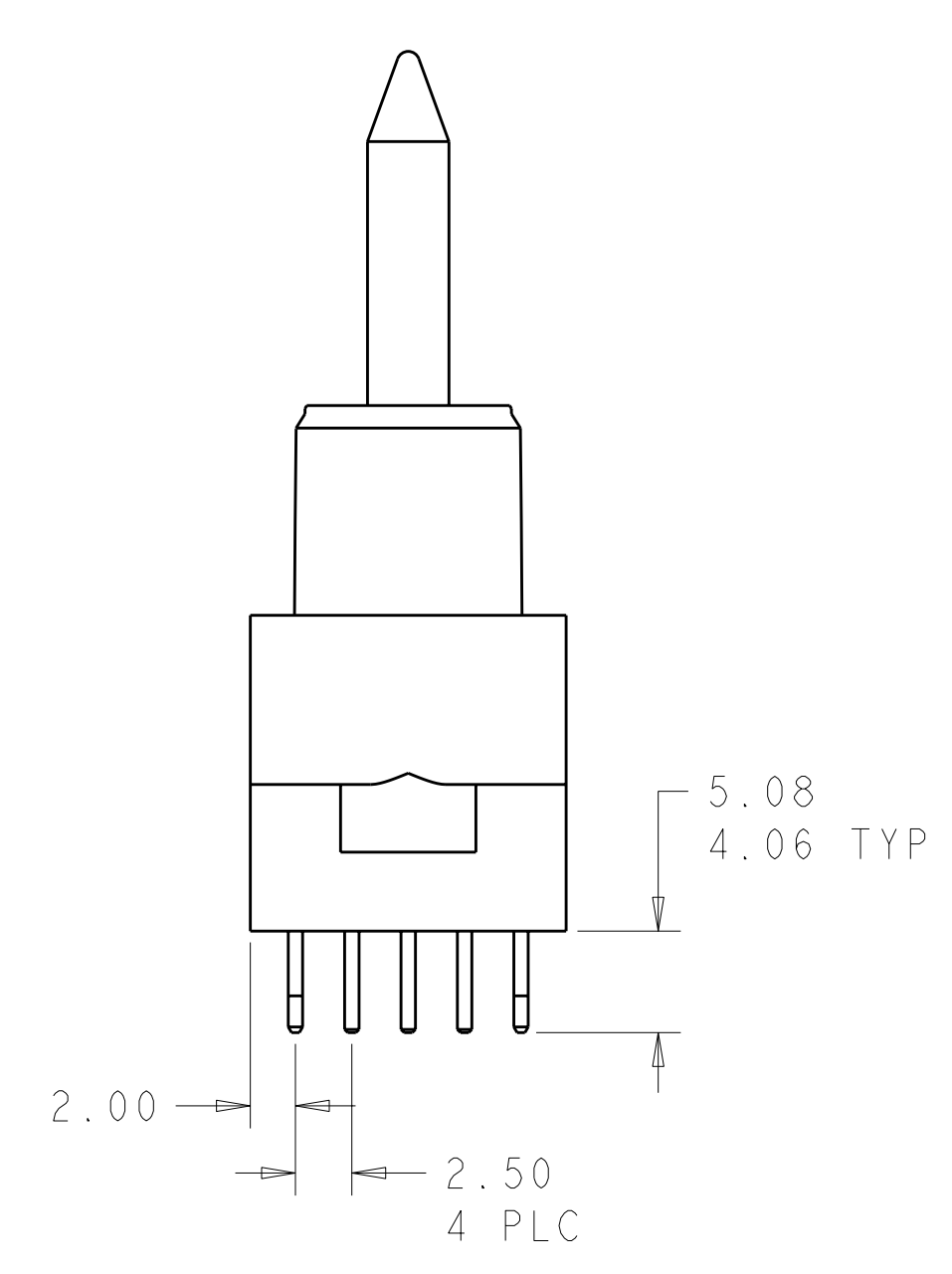
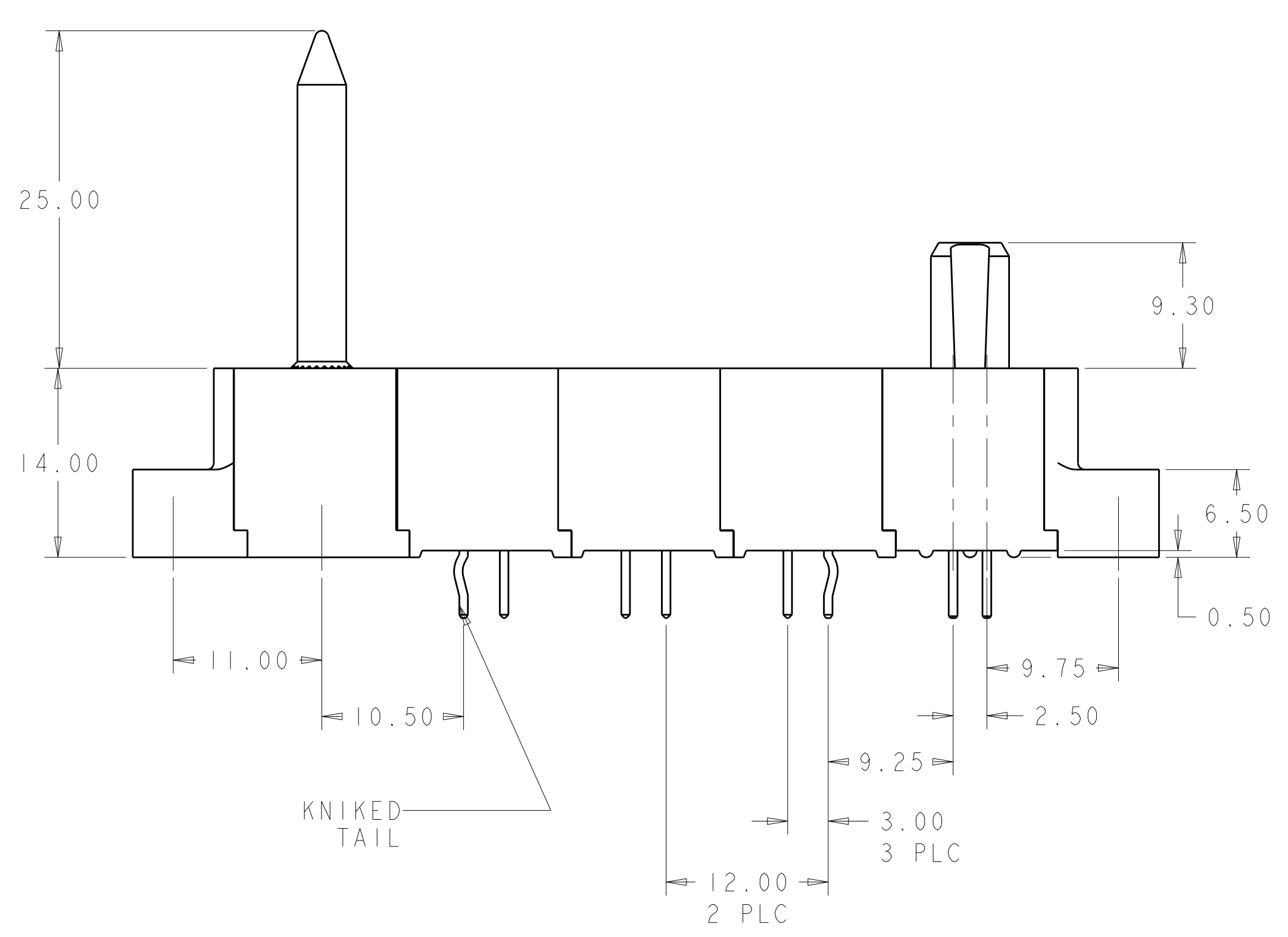

ELCON **FLATPAQ**

| | | | |
|---|--|---|--|
| AS SHOWN | | 1892812-1 | |
| DESCRIPTION | | PART NUMBER | |
| <small>THIS DRAWING IS UNPUBLISHED. RELEASED FOR PUBLICATION 20 BY TYCO ELECTRONICS CORPORATION, ALL RIGHTS RESERVED.</small> DIMENSIONS: mm TOLERANCES UNLESS OTHERWISE SPECIFIED: 9 PLC ±.5 5 PLC ±.25 4 PLC ±.3 ANGLES ±.3 FINISH: - MATERIAL: - | | DWN ORANDO LI 15FEB2012 CBY SUNY ZHAO 15FEB2012 APVD SUNY ZHAO 15FEB2012 PRODUCT SPEC: - APPLICATION SPEC: 114-13284 WEIGHT: - CUSTOMER DRAWING | |
| Tyco Electronics Harrisburg, PA 17105-3608 | | NAME: SOCKET CONNECTOR, STRAIGHT SOLDER TAILS FLATPAQ SIZE: A 00779 C=1892812 SCALE: 3:1 SHEET 1 OF 3 REV A | |

| LOC | DIST | REVISIONS | | | | | |
|-----|------|-----------|-----|-------------|------|-----|------|
| GP | 00 | P | LTB | DESCRIPTION | DATE | DWN | APVD |
| | | - | - | SEE SHEET 1 | - | - | - |

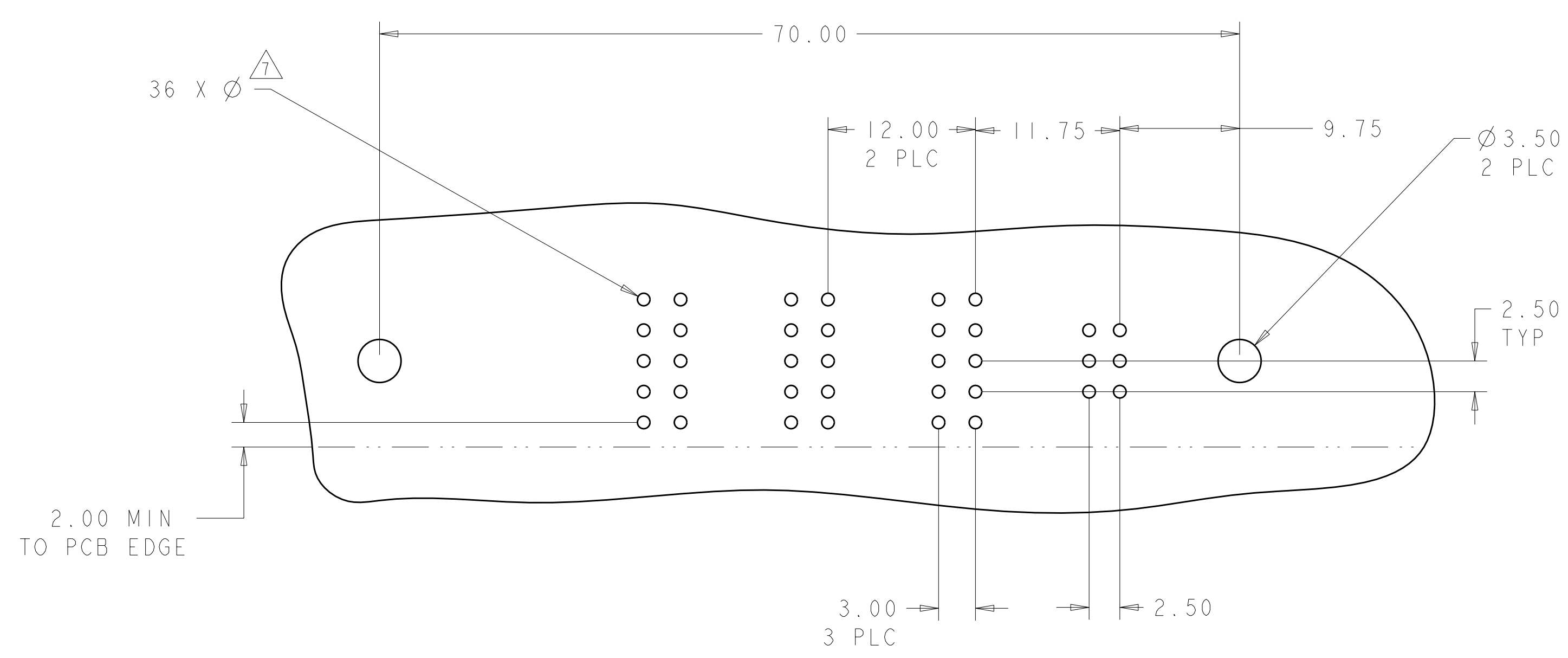

PRINTED CIRCUIT LAYOUT
 COMPONENT SIDE

| CONNECTOR | CATALOG MODULE # | QTY | SIZE NO. | CONTACT QTY | MATING PIN | MAX. CURRENT (PER CONTACT) | CONTACT SPACING | VOLTAGE RATING | |
|-----------|------------------|-----|------------------------|-------------|------------------------------|----------------------------|-----------------|----------------|--|
| SOCKET | FP154 | 3 | 8 | 3 | 1.25 X 7.00 [.049 X .276] | 35 amps | 12.0 [.2953] | 600 VOLTS | |
| | FP313 | 1 | 8 | 6 | .64 [.025] SQ. | 3 amps | 2.50 [.0984] | 125 VOLTS | |
| | FP503 | 1 | GUIDE PIN, PASSIVE | | | | | | |
| | FP500 | 1 | MOUNTING FLANGE, LEFT | | | | | | |
| | FP501 | 1 | MOUNTING FLANGE, RIGHT | | | | | | |

| | | | |
|---|--|--|---|
| <small>THIS DRAWING IS UNPUBLISHED. RELEASED FOR PUBLICATION BY TYCO ELECTRONICS CORPORATION. ALL RIGHTS RESERVED.</small> <small>THIS IS SUBJECT TO CHANGE WITHOUT NOTICE. THE USER SHALL BE RESPONSIBLE FOR VERIFYING THE DIMENSIONS AND TOLERANCES OF THE PARTS AND CONTACTS FOR THE LATEST REVISION.</small> | | DWN: ORLANDO LI 15FEB2012 CHK: SUNY ZHAO 15FEB2012 APVD: SUNY ZHAO 15FEB2012 | Tyco Electronics Harrisburg, PA 17105-3608 |
| DIMENSIONS: mm | TOLERANCES UNLESS OTHERWISE SPECIFIED: 9 PLC ±.5 1 PLC ±.5 2 PLC ±.25 3 PLC ±.25 4 PLC ±.25 ANGLES ±.3 FINISH | NAME: SUNY ZHAO PRODUCT SPEC: APPLICATION SPEC: 114-13284 WEIGHT: | NAME: SOCKET CONNECTOR, STRAIGHT SOLDER TAILS FLATPAQ SIZE: A 00779 C=1892812 SCALE: 3:1 SHEET 2 OF 3 REV A |
| MATERIAL: - | | CUSTOMER DRAWING | |

