

LOC		DIST		REVISIONS			
P	LTN	DESCRIPTION	DATE	DMN	APVD		
A		INITIAL RELEASE	13SEP2013	TV	IS		
B		INCREASE DRAFT INSIDE MATERIAL SAVING	29NOV2017	TV	IS		

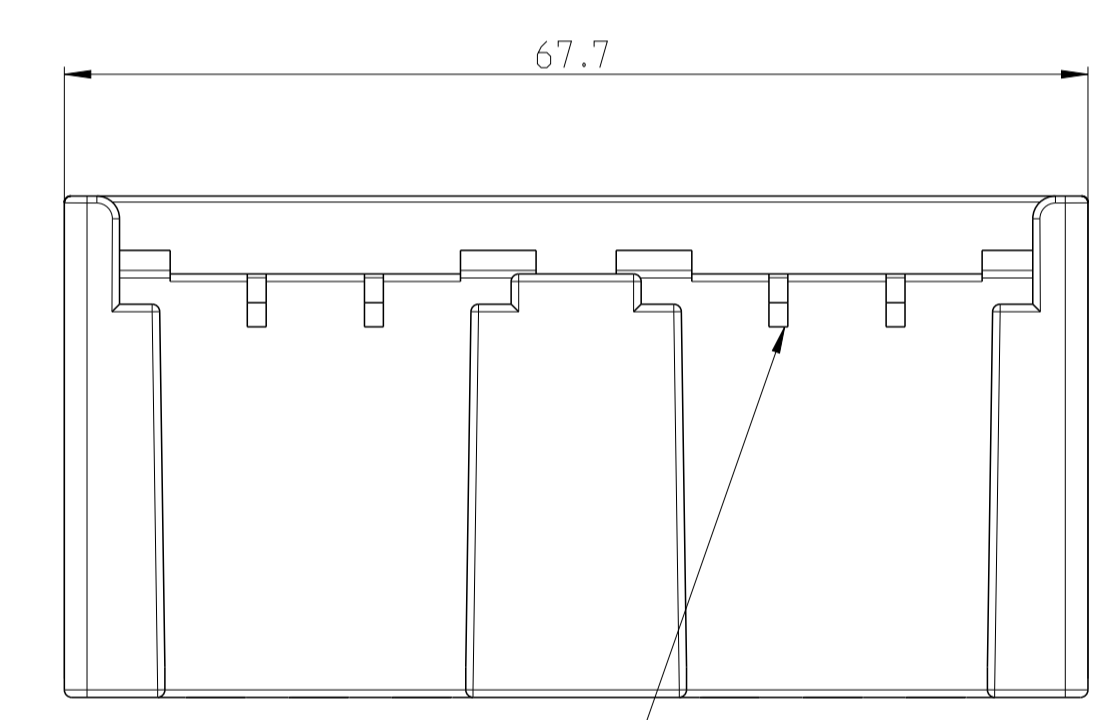

DOUBLE FEMALE BOX LOCKING INTERFACE ACCORDING TO TE INTERFACE DRAWING 1801632

HOLDER LOADING CAPACITY	QUANTITY	10
	DESIGNATION	MINIATURE FUSE

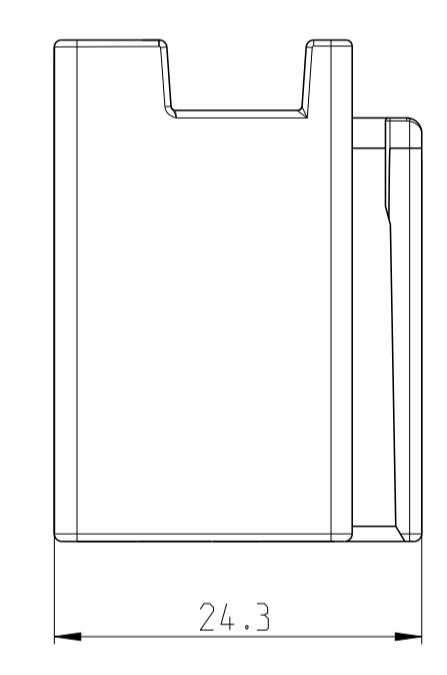
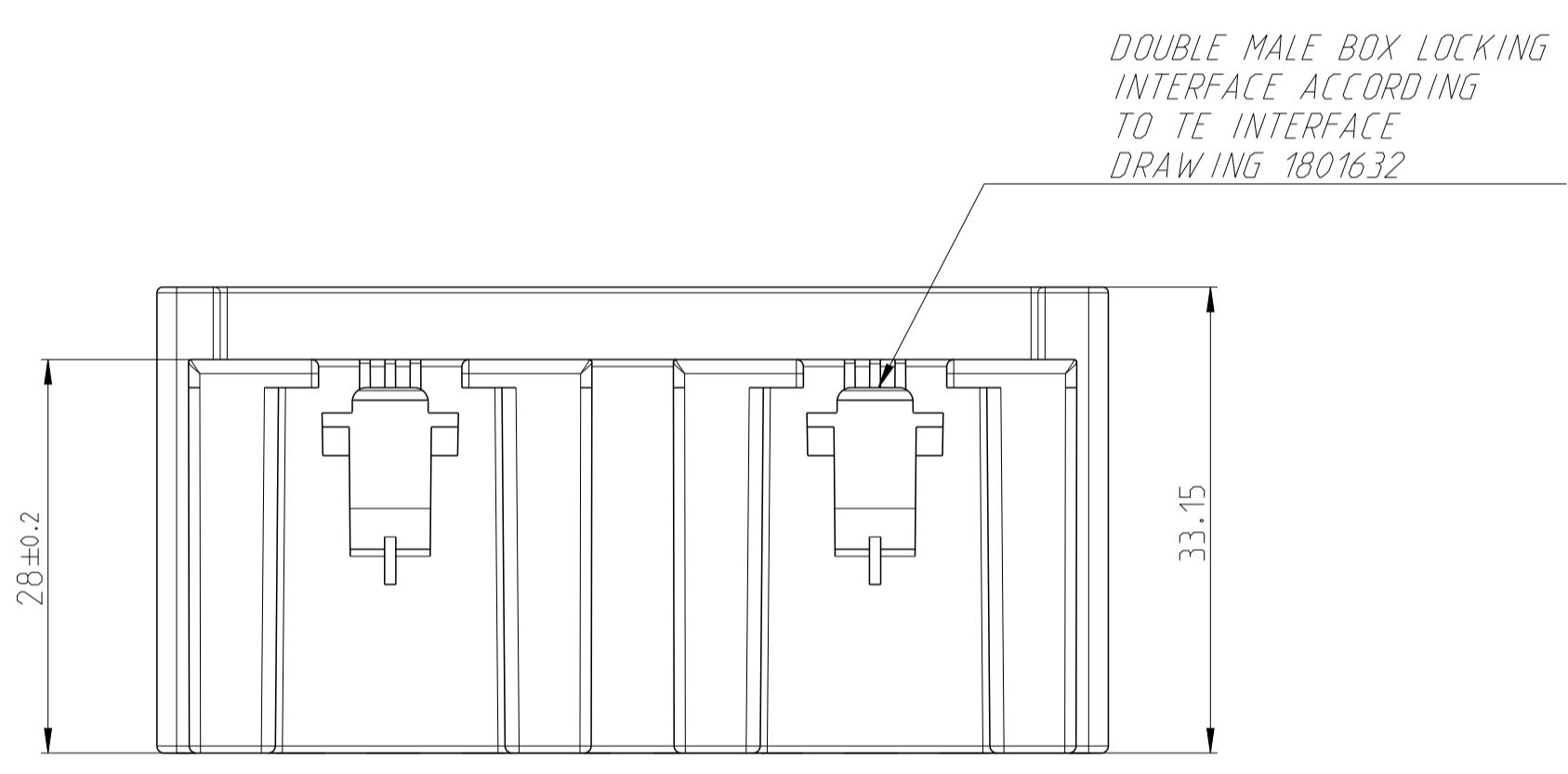
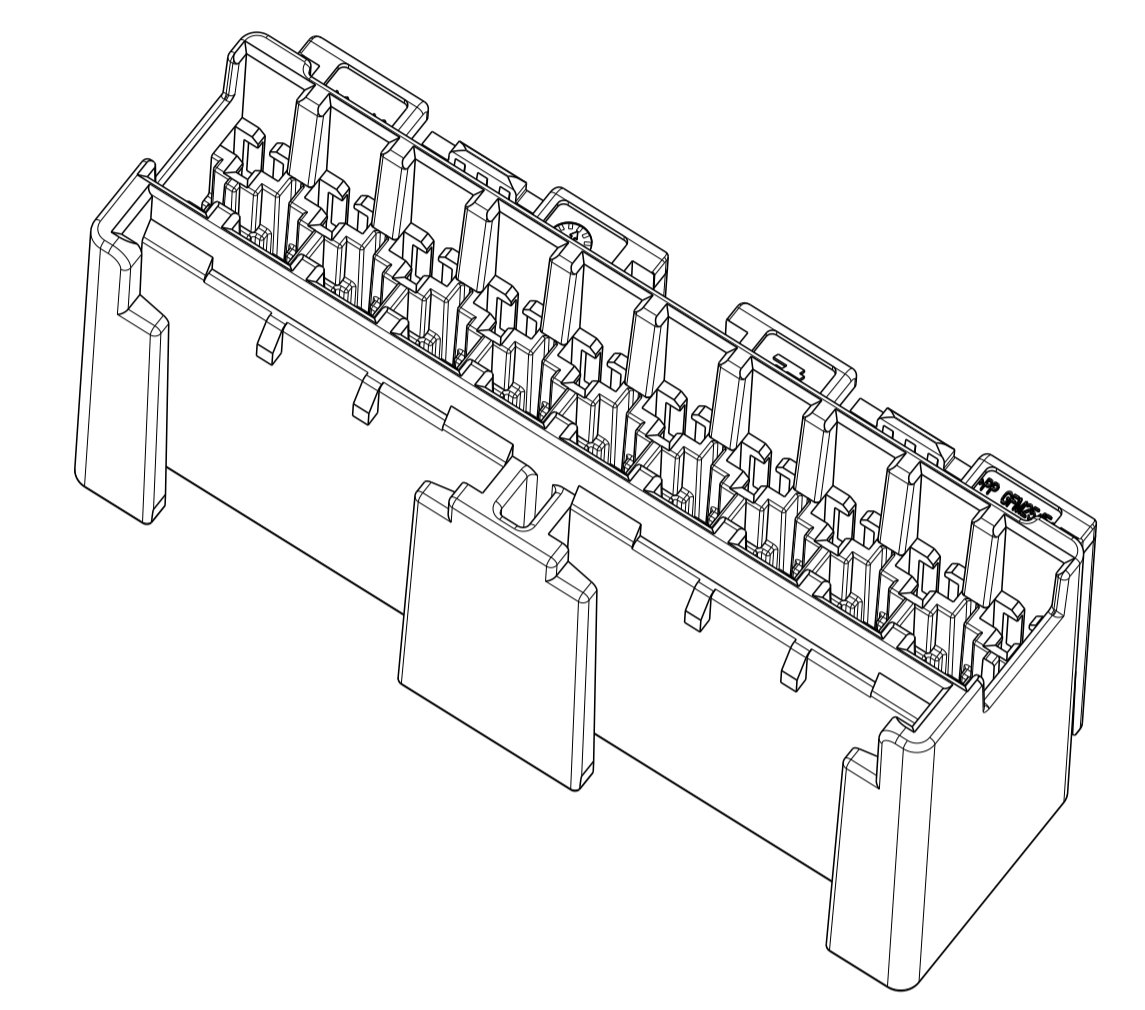
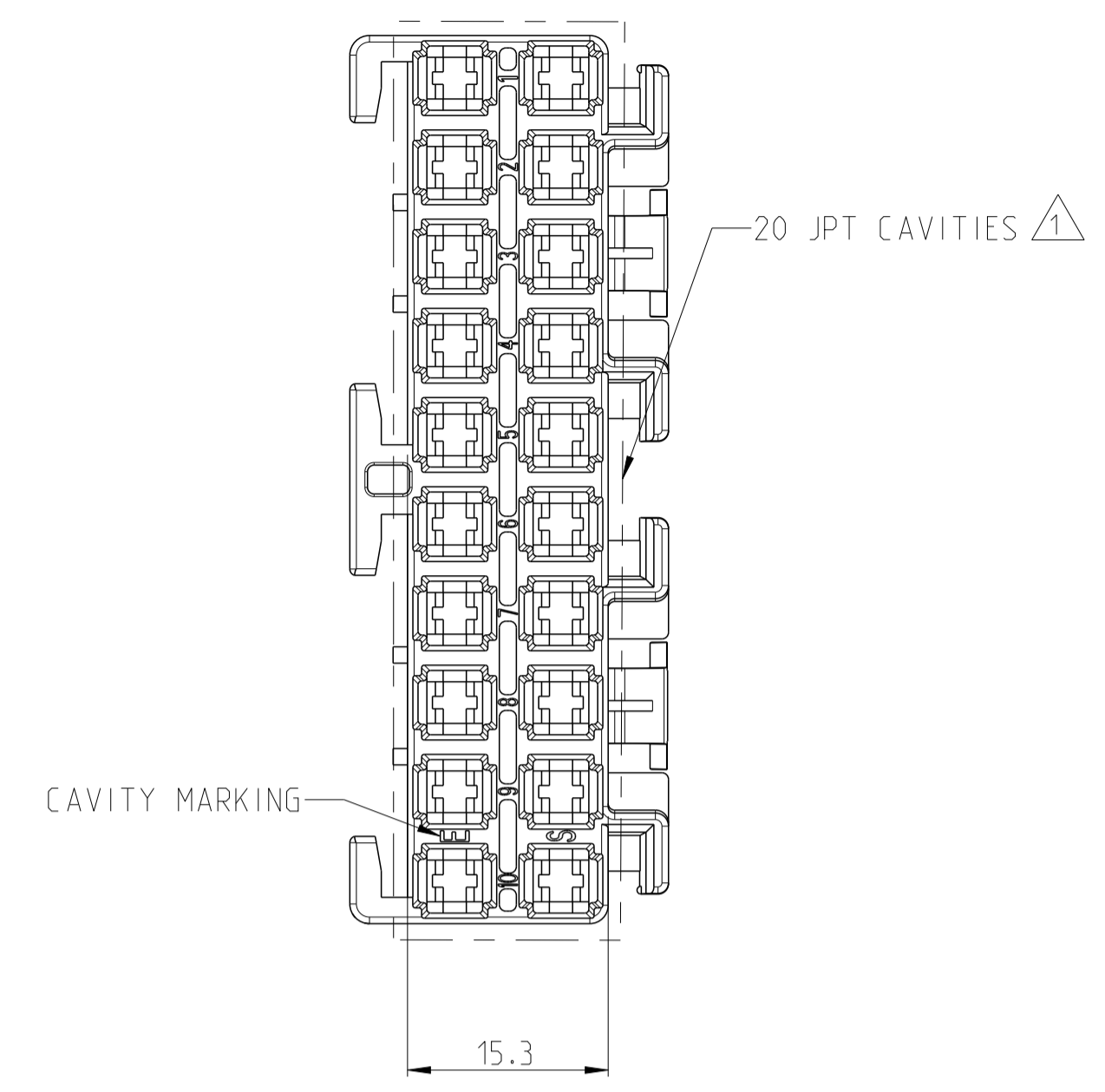
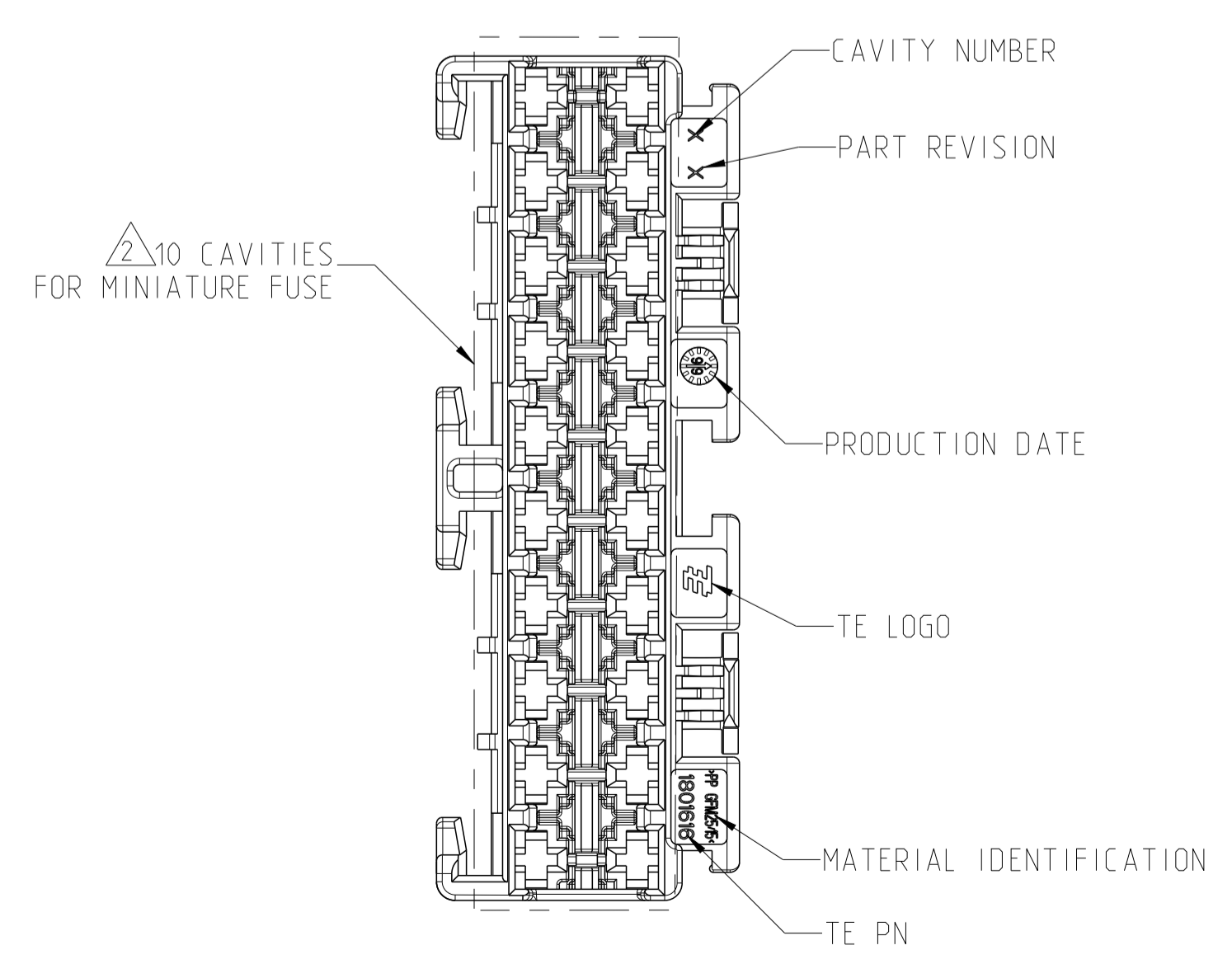

DESCRIPTION	TE PN	COMMENTS
△ JPT 2.5 - 4 mm <sup>2</sup>	0-1241978-2	/
△ JPT 1 - 2.5 mm <sup>2</sup>	0-0965999-2	/
△ JPT 0.5 - 1 mm <sup>2</sup>	0-0964284-2	/
△ JPT 0.2 - 0.5 mm <sup>2</sup>	0-0964280-2	/
MINIATURE FUSE ACCORDING TO ISO 8820-3	/	MINIATURE FUSE-LINKS WITH TABS
APPLIED COMPONENTS		

PP GFM 25/15	BLACK	1801616-1	D (B)
MATERIAL	COLOR	TE PN	TE PRC PART REVISION

THIS DRAWING IS A CONTROLLED DOCUMENT.

DMN: J. DREUX 10SEP2013		NAME: 10 MINIATURE FUSES HOLDER PRODUCT SPEC: - APPLICATION SPEC: -
CHK: T. VERNIER 10SEP2013		
APVD: L. SMIRANI 10SEP2013		
APVD: L. SMIRANI 10SEP2013		

DIMENSIONS: mm	TOLERANCES UNLESS OTHERWISE SPECIFIED:	SIZE: A1	CAGE CODE: 00779	DRAWING NO: C=1801616	RESTRICTED TO: -
0 PLC ±0.4	1 PLC ±0.4	2 PLC ±0.4	3 PLC ±0.4	4 PLC ±0.4	ANGLES ±45°
MATERIAL: SEE TABLE	FINISH: -	WEIGHT: 24g	CUSTOMER DRAWING		

SCALE: 2:1 SHEET 1 OF 1 REV B