

P	LTR	DESCRIPTION	DATE	DWN	APVD
	C3	REVISED PER ECR-19-017851	20NOV2019	SM	DZ
	C4	REVISED PER ECR-24-213430	26JUL2024	MV	CP

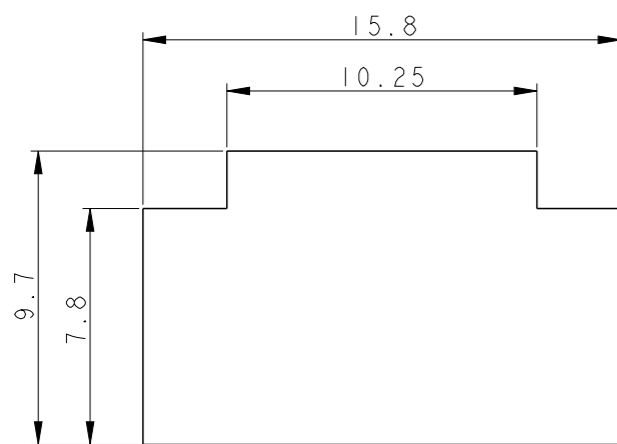

RECOMMENDED PANEL OPENING DIMENSION

TOLERANCES: ±0.13

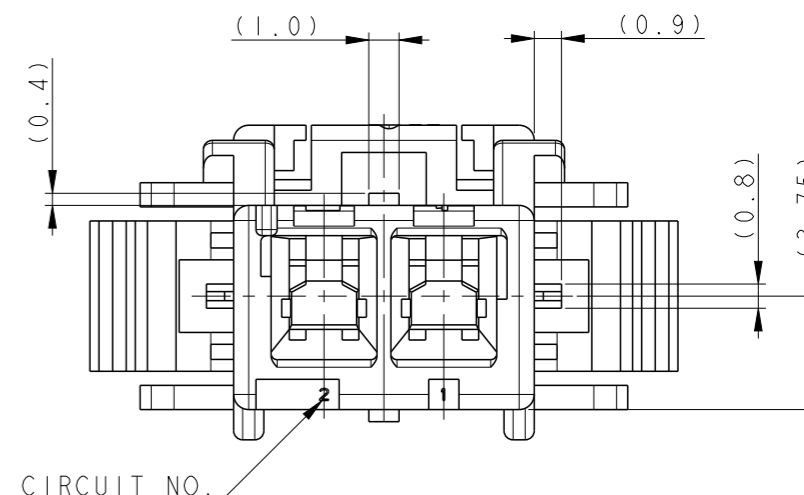
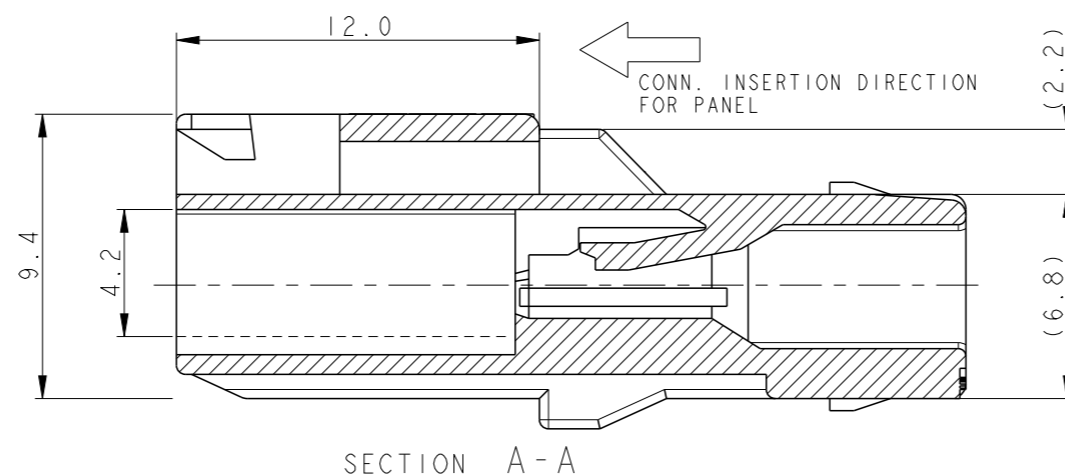
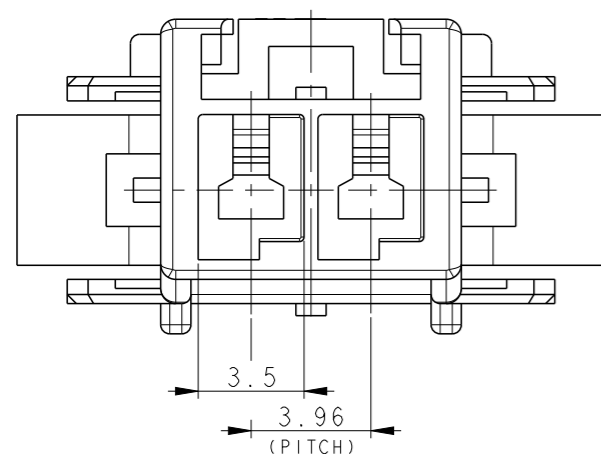
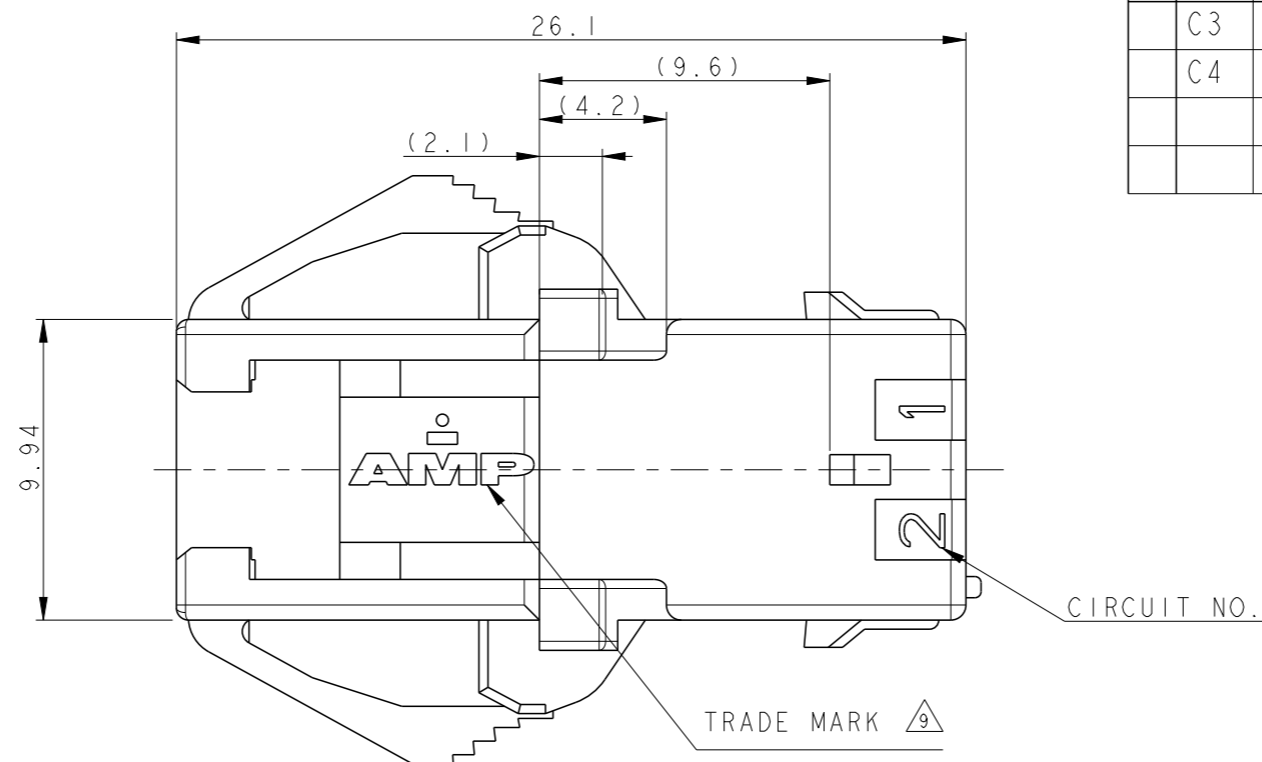

- NOTE;
- PRODUCT SPEC, 108-5410
  - APPLICABLE CONTACT P/N:  
TAB CONTACT: 177917-□ (AWG#16-#20)  
177916-□ (AWG#22-#26)
  - MATING CONN. P/N  
PLUG HSG: 177898-□  
REC CONTACT: 177915-□ (AWG#16-#20)  
: 177914-□ (AWG#22-#26)

- APPLICABLE PLATE: 177918-□
- INSTRUCTION SHEET: 411-5638
- APPLICABLE PANEL THICKNESS: 0.8~2.0 (SEE FIG 1).
- INSERT CONN. FROM PRESS DIRECTION SIDE FOR METAL PANEL.
- EDGE OF THICKNESS MAY MUST NOT ROUND FOR MOLDED PANEL.
- SEE TABLE 1.
- PART 5-177906-1 COMPLY WITH GLOW WIRE REQUIREMENT FOR PARTS OF NON-METALLIC MATERIAL SUPPORTING A CURRENT CARRYING CONNECTION DETAILED IN IEC 60335-1, SECTION 30(GWT)
- APPLICATION SPEC: 114-5175

△(TABLE 1)

TRADE MARK	MANUFACTURING PLACE
-AMP OR AMP	JAPAN
-+AMP OR AMP	CHINA (PRC)
-AMP OR AMP	KOREA

COLOR	Pos	PART NUMBER
NATURAL	2	5-177906-1
BLACK	2	177906-9
BLUE	2	177906-6
YELLOW	2	177906-4
RED	2	177906-2
NATURAL	2	177906-1

THIS DRAWING IS A CONTROLLED DOCUMENT.		DWN M. SUZUKI 09SEPI993												
DIMENSIONS: mm		CHK M. SHINDO 09SEPI993												
TOLERANCES UNLESS OTHERWISE SPECIFIED:		APVD Y. KASHIWA 09SEPI993												
<table border="1"> <tr> <td>0 PLC</td> <td>±0.3</td> </tr> <tr> <td>1 PLC</td> <td>±0.25</td> </tr> <tr> <td>2 PLC</td> <td>±0.2</td> </tr> <tr> <td>3 PLC</td> <td>±</td> </tr> <tr> <td>4 PLC</td> <td>±</td> </tr> <tr> <td>ANGLES</td> <td>±3°</td> </tr> </table>		0 PLC			±0.3	1 PLC	±0.25	2 PLC	±0.2	3 PLC	±	4 PLC	±	ANGLES
0 PLC	±0.3													
1 PLC	±0.25													
2 PLC	±0.2													
3 PLC	±													
4 PLC	±													
ANGLES	±3°													
MATERIAL 6/6 NYLON (UL94V-0)		FINISH	NAME POWER DOUBLE LOCK CONN 3.96mm CAP HOUSING 2P (PANEL MOUNT)											
CUSTOMER DRAWING		WEIGHT	SIZE A3	CAGE CODE 00779										
			DRAWING NO. C-177906	RESTRICTED TO										
			SCALE 4:1	SHEET 1 OF 1										
				REV C4										