

THIS DRAWING IS UNPUBLISHED. RELEASED FOR PUBLICATION 20
 © COPYRIGHT 20 BY - ALL RIGHTS RESERVED.

LOC		DIST		REVISIONS			
P	LTR	DESCRIPTION	DATE	DWN	APVD		
	4	REVISED PER ECO-14-016550	17NOV14	MGM	CT		

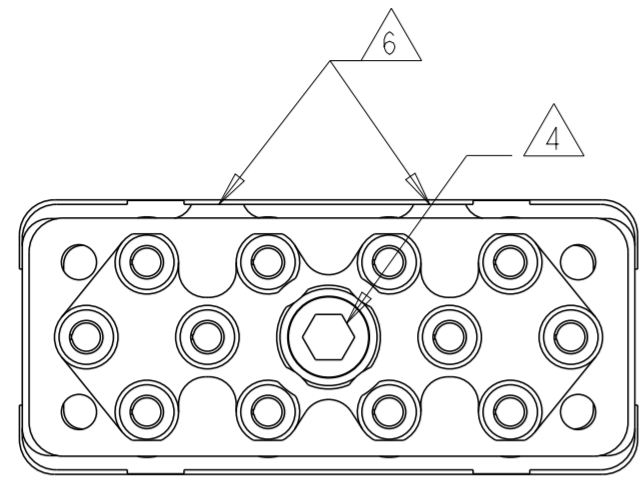

MATING FACE

- 1 FRONT HOUSING, REAR HOUSING, SLEEVE HOLDER: ALUMINUM ALLOY
 TERMINI RETENTION CLIPS: COPPER ALLOY PER ASTM B194
 SLEEVE HOLDER SCREW, HOUSING NUT, REAR RETAINING SCREW: STAINLESS STEEL PER AISI 303.
 REAR GROMMET & INTERFACIAL SEAL: FLUOROSILICONE ELASTOMER PER MIL-R-25988B EXCEPT 4.6.6.1
 SLEEVES: ZIRCONIA
- 2 FRONT HOUSING, REAR HOUSING, SLEEVE HOLDER: CLEAR ANODIZED.
- 3 THE SLEEVE HOLDER IS ALSO AVAILABLE SEPARATELY, TEC P/N 1811769-1.
- 4 HEX KEY SLOT FOR 9/64 ALLEN WRENCH.
- 5 DATE CODE: YEAR & WEEK (YY WW)
 THE PART NUMBER MAY BE LOCATED ON EITHER THE REAR HOUSING OR THE REAR GROMMET.
- 6 KEYING FEATURES: TWO PROTRUSIONS FOR KEYING CODE B
- 7. DESCRIPTIVE PART NUMBER GPRBEF12SB
 THIS INSERT CONTAINS: 12 CAVITIES FOR SIZE 16 ARINC 801 OPTICAL CONTACTS.
- 8. THIS PRODUCT IS SOLD BY TE CONNECTIVITY UNDER A LICENSE FROM RADIAL SA.

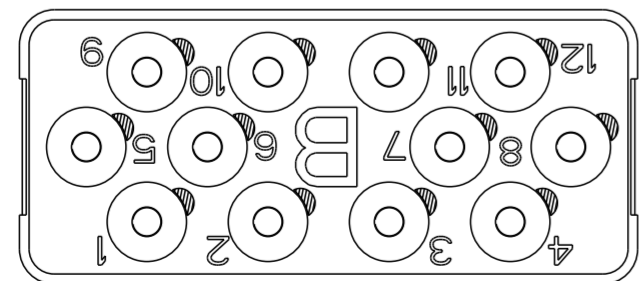
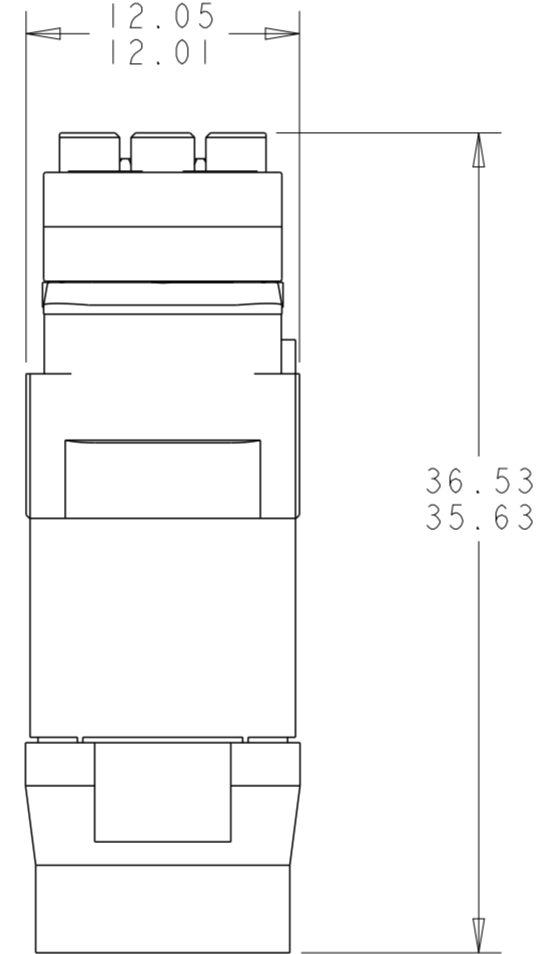
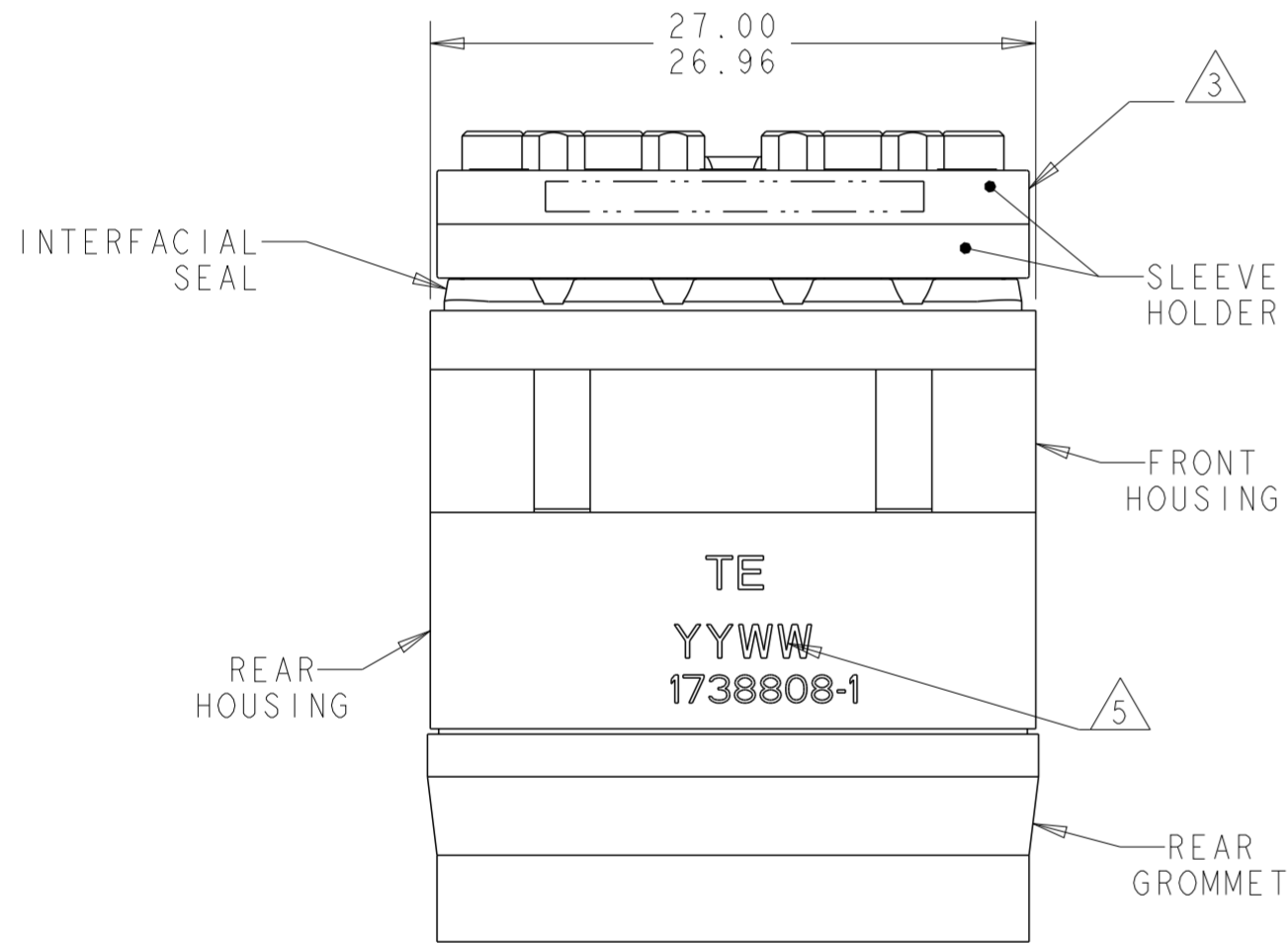

REAR FACE

1738808-1
 PART NUMBER

THIS DRAWING IS A CONTROLLED DOCUMENT. DIMENSIONING AND TOLERANCING PER ASME Y14.5M-2009		DWN BH 18FEB2005	STE TE Connectivity	
DIMENSIONS: mm		CHK JPM 18FEB2005		
TOLERANCES UNLESS OTHERWISE SPECIFIED:		APVD JPM 18FEB2005	NAME INSERT ASSEMBLY, WITH SLEEVE HOLDER, ENVIRONMENTAL, F12, KEY B, GPRB	
0 PLC ±	1 PLC ±0.1	PRODUCT SPEC -	SIZE A2	CAGE CODE 00779
2 PLC ±0.13	3 PLC ±	APPLICATION SPEC -	DRAWING NO C-1738808	RESTRICTED TO -
4 PLC ±	ANGLES ±1	WEIGHT -	SCALE 3:1	SHEET 1 OF 1
MATERIAL 1 -	FINISH 2 -	Customer Drawing	REV 4	