

LOC	DIST	REVISIONS			
P	LTB	DESCRIPTION	DATE	DWN	APVD
A	-	NEW PART, NEW DRAWING	20DEC2007	YA	HR
A1	-	PCN-E-08-027108	26MAY2009	YA	HR
B	-	E-09-026750	08DEC2009	YA	HR

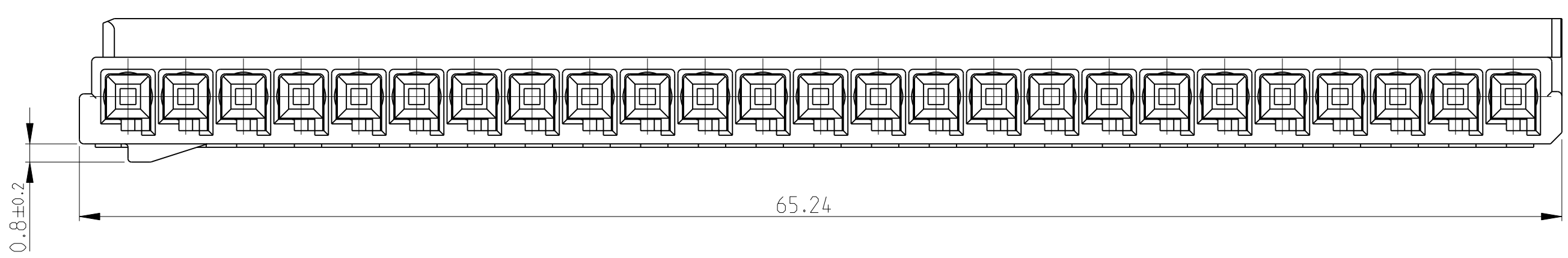
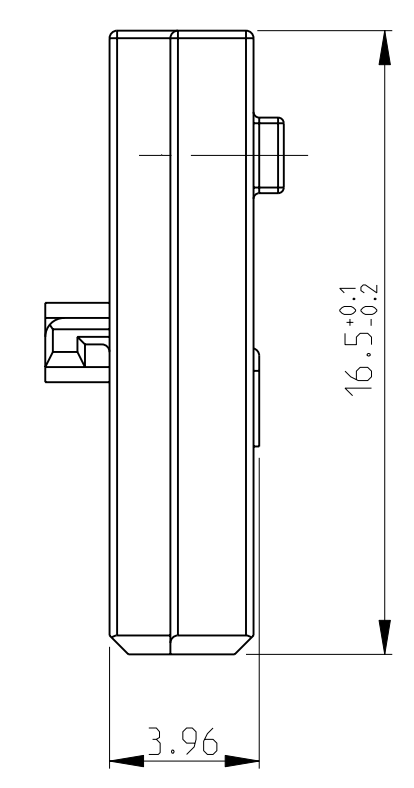
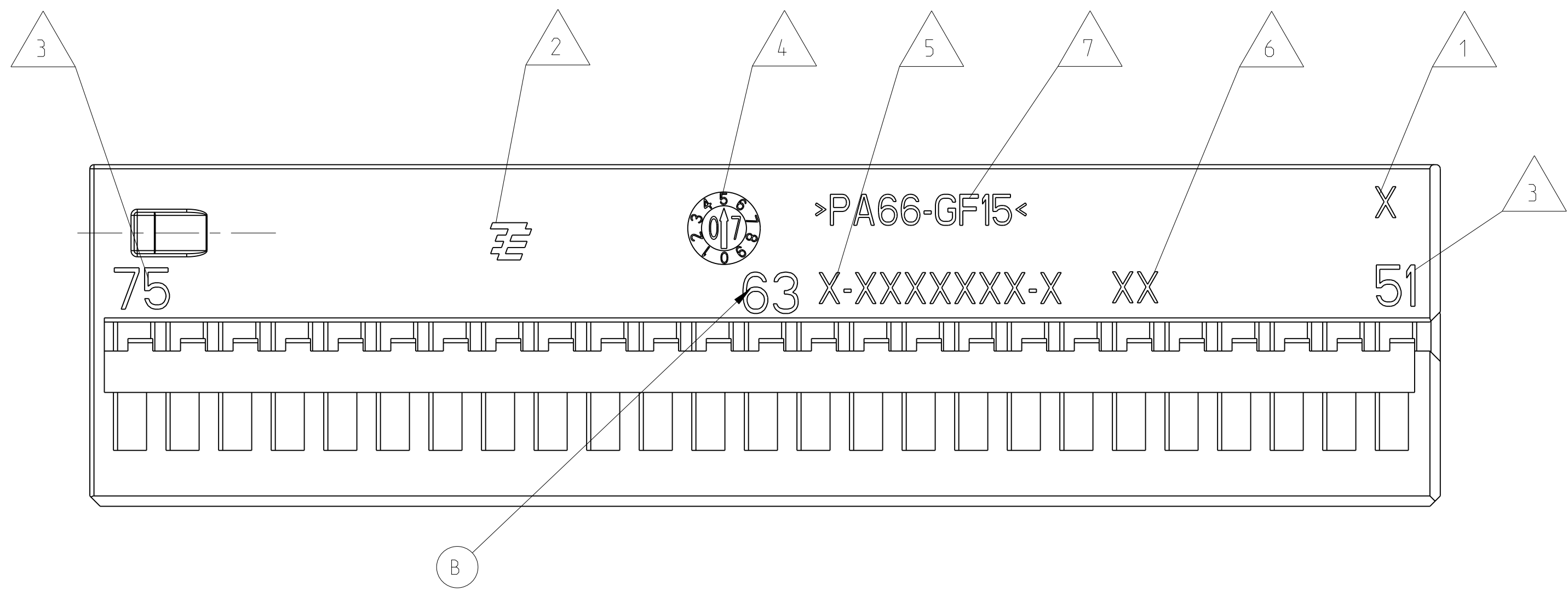
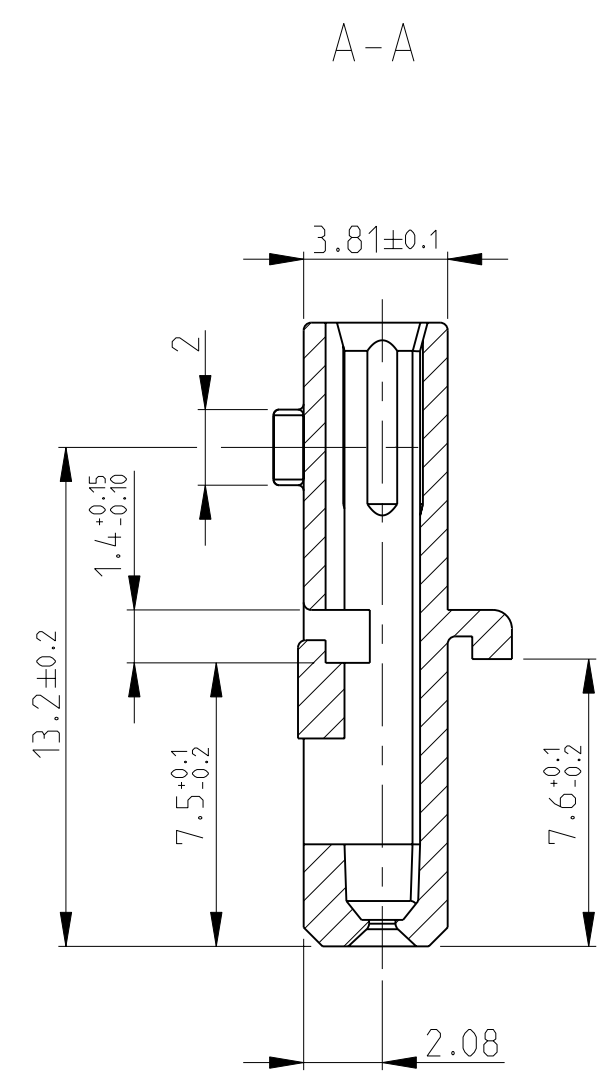
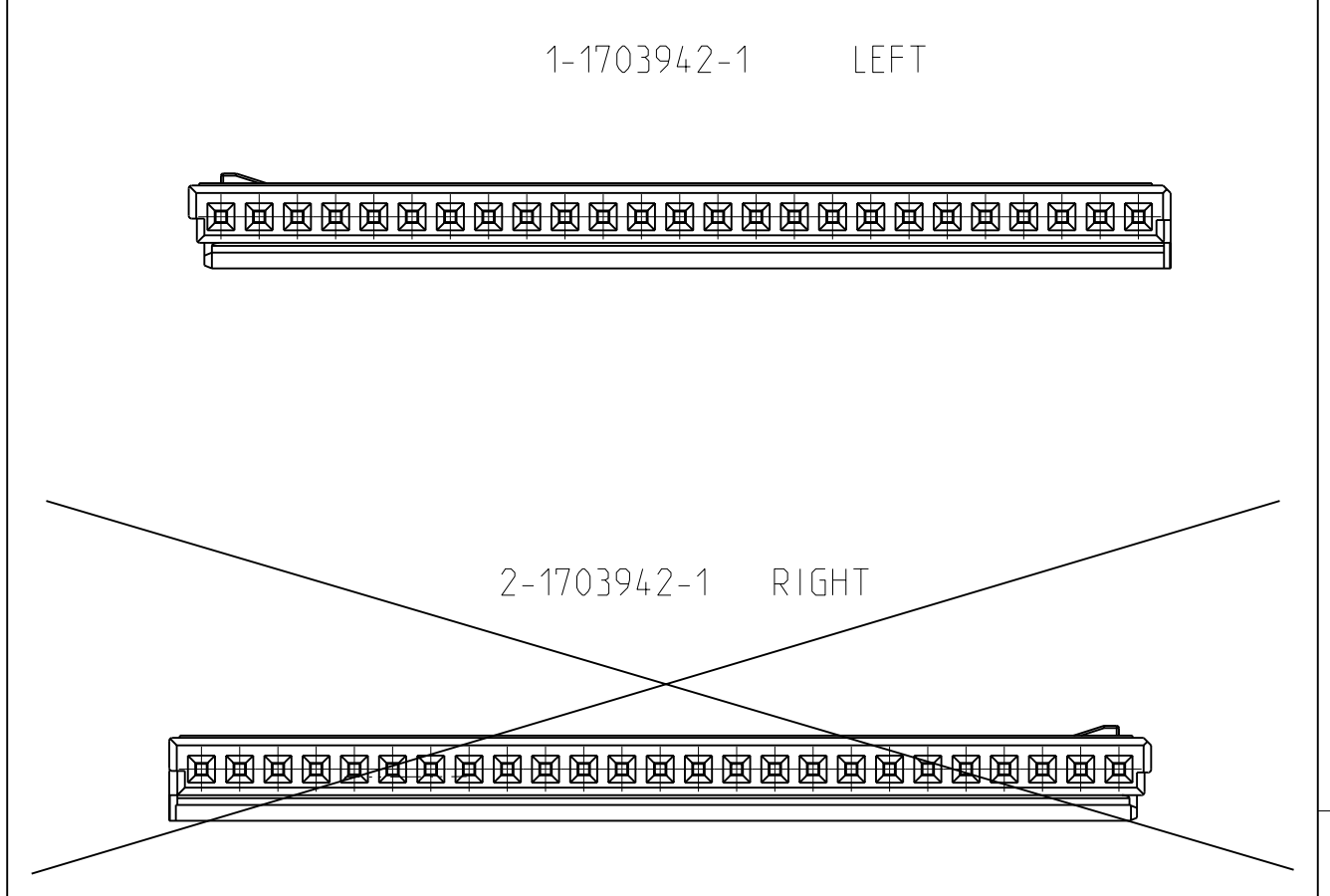
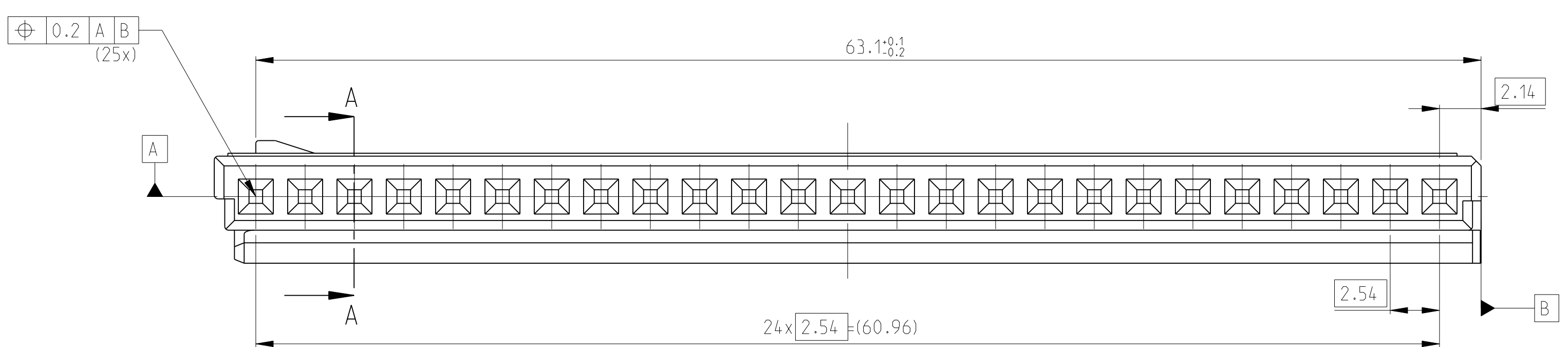

- NOTES:  
Bemerkungen:
- 1 CAVITY MARKING  
Nestmarkierung
  - 2 TE-LOGO  
TE-Logo
  - 3 CONTACT CAVITY NUMBER  
Kontaktkammernummer
  - 4 PRODUCTION DATE  
Produktionsdatum
  - 5 TE PART NO.  
TE Teile Nr.
  - 6 PART REVISION  
Teile Revision
  - 7 MATERIAL IDENTIFICATION  
Werkstoffkennzeichnung
  - 8 BULK PACKAGED  
Verpackt als Schuetztgut
- RECOMMENDED TERMINALS, TE ORDER NO.  
 963715-X WSR 0.5-0.75 (mm<sup>2</sup>), u. 928999-X, WSR 0.25-0.5 (mm<sup>2</sup>)  
 Empfohlene Kontakte, TE Bestellnr.  
 963715-X WSR 0.5-0.75 (mm<sup>2</sup>), u. 928999-X, WSR 0.25-0.5 (mm<sup>2</sup>)
- 1- -1 AS SHOWN  
Wie gezeigt

USEABLE COVER	VERSION	PART NO.	REV.	COLOR	WEIGHT (g)
3-1703938-1	RIGHT	2-1703942-1	B	Black	2.7
1-1703938-1 u. 2-1703938-1	LEFT	1-1703942-1	B	Gray	2.7

DIMENSIONS: mm 		TOLERANCES UNLESS OTHERWISE SPECIFIED: 0 PLC ±0.3 1 PLC ±0.3 2 PLC ±0.3 3 PLC ±0.3 4 PLC ±0.3 ANGLES ±° FINISH -		DWN T. Astour 14DEC2007 CHK H. Ripper 20DEC2007 APVD - NAME - PRODUCT SPEC - APPLICATION SPEC - WEIGHT - CUSTOMER DRAWING -		Tyco Electronics AMP GmbH 0 - 64625 Bensheim MQS, SOCKET HOUSING, 25 POS. MQS, Buchsengehaeuse, 25 pol. SIZE CAGE CODE DRAWING NO RESTRICTED TO A 00779 C=1703942 SCALE 5:1 SHEET 1 OF 1 REV B	
-----------------------	--	---	--	--	--	--	--

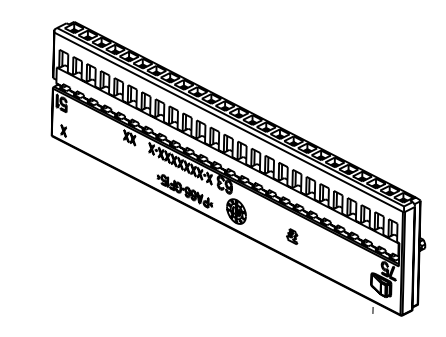

1:1