

THIS DRAWING IS UNPUBLISHED. RELEASED FOR PUBLICATION
 © COPYRIGHT - By - ALL RIGHTS RESERVED.

REVISIONS					
P	LTR	DESCRIPTION	DATE	DWN	APVD
A		NEW DRAWING	28NOV2016	RS	TD

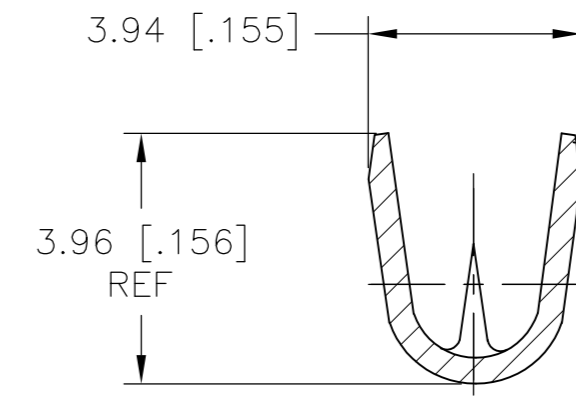

SECTION A-A

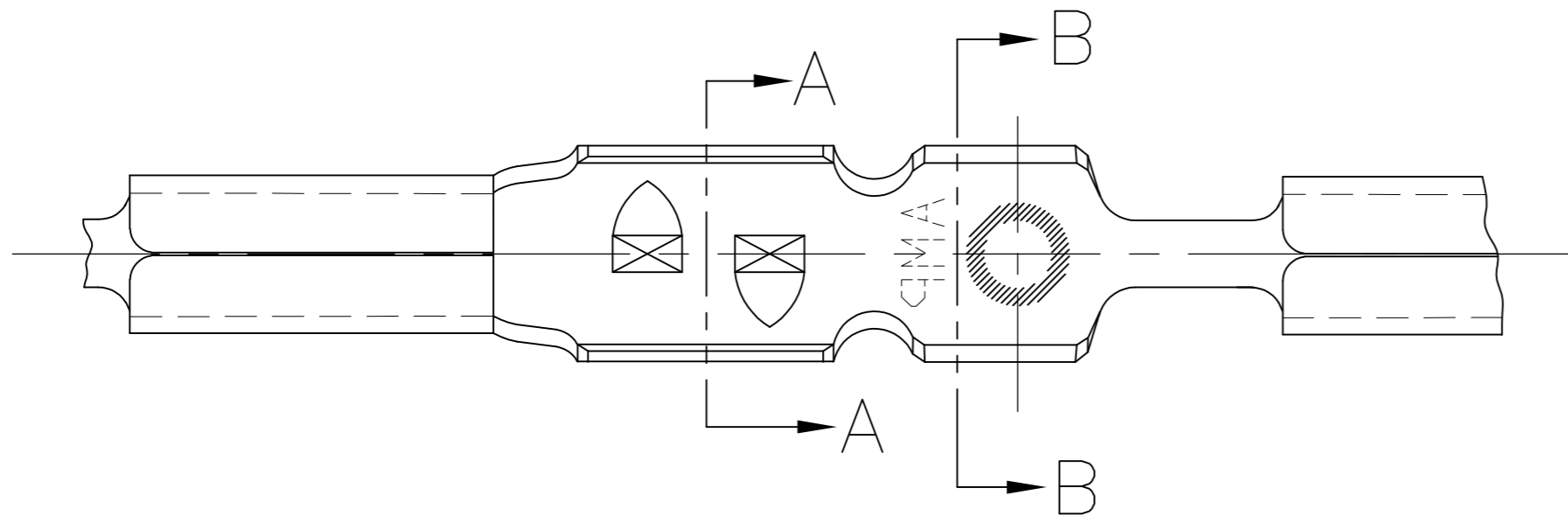
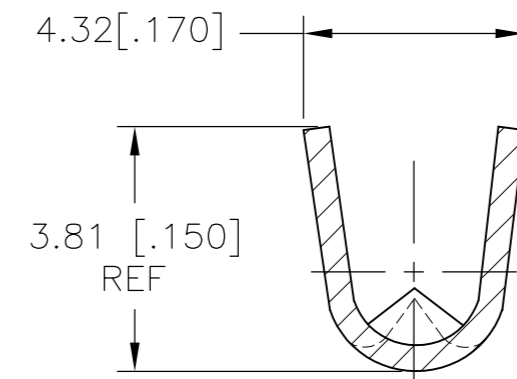
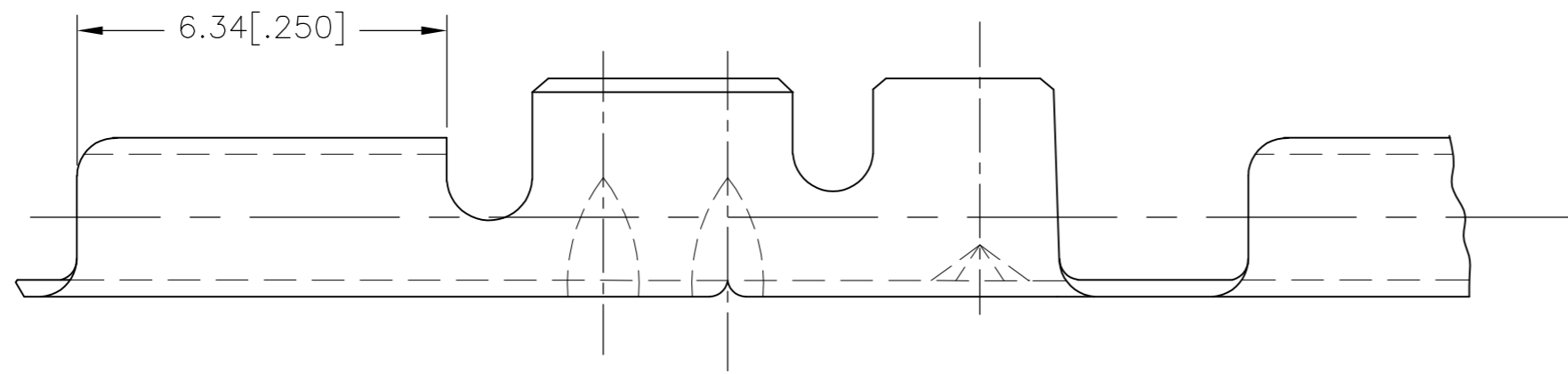
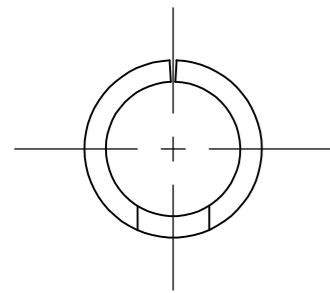

SECTION B-B

STOCK THK: 0.32 [.0126]	
CODE	MATERIAL DESCRIPTION
A	BRASS
B	COPPER
C	STEEL
CODE	PLATING DESCRIPTION
1	PRE-TIN
2	ELECTRO-TIN

APPLICATOR FEED DIRECTION	
THIS DRAWING IS A CONTROLLED DOCUMENT.	
DIMENSIONS: mm [INCHES]	TOLERANCES UNLESS OTHERWISE SPECIFIED:
	0 PLC ± -
	1 PLC ± -
	2 PLC ± 0.40 [.015]
	3 PLC ± 0.40 [.015]
4 PLC ± -	ANGLES ± -
MATERIAL SEE TABLE	FINISH SEE TABLE

WIRE RANGE: TINSEL INS. RANGE: Ø.095-.115	4000 A-1 160461-2 8000 A 160461-1
QTY/REEL	MAT PART NO
 TE Connectivity	
PIN REC.	
SIZE A2	CAGE CODE 00779
DRAWING NO C=160461	RESTRICTED TO -
CUSTOMER DRAWING	SCALE 6:1 SHEET 1 of 1 REV A