

THIS DRAWING IS UNPUBLISHED. RELEASED FOR PUBLICATION
 © COPYRIGHT - By - ALL RIGHTS RESERVED.

REVISIONS					
P	LTR	DESCRIPTION	DATE	DWN	APVD
A		NEW DRAWING	15NOV2016	RS	TD

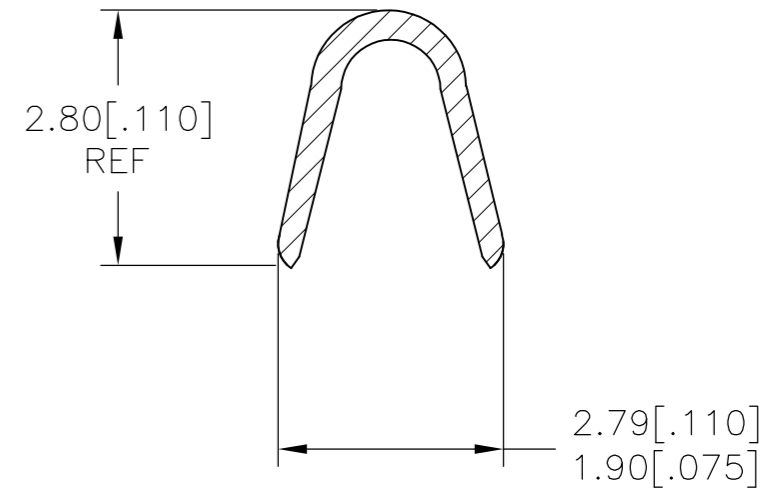

SECTION B-B
SCALE 8:1

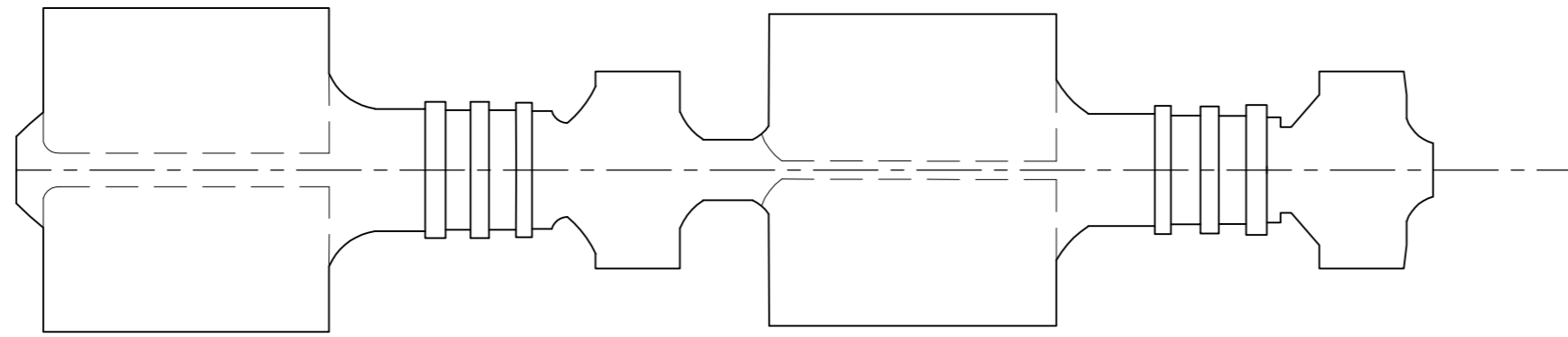
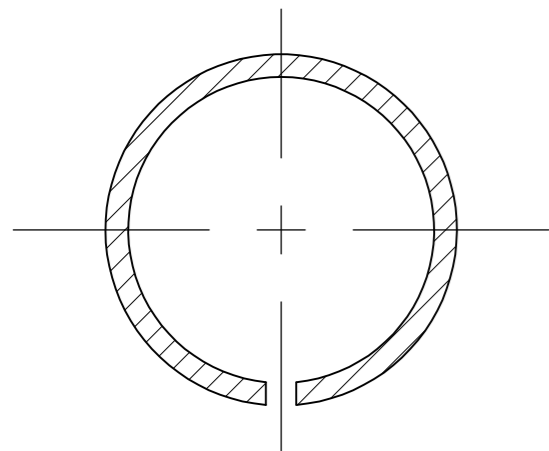

SECTION A-A
SCALE 8:1

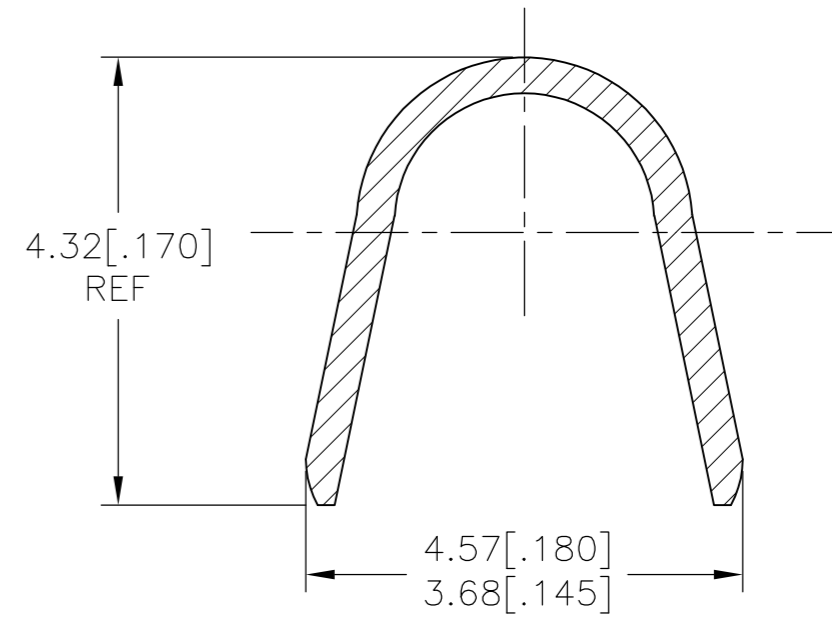
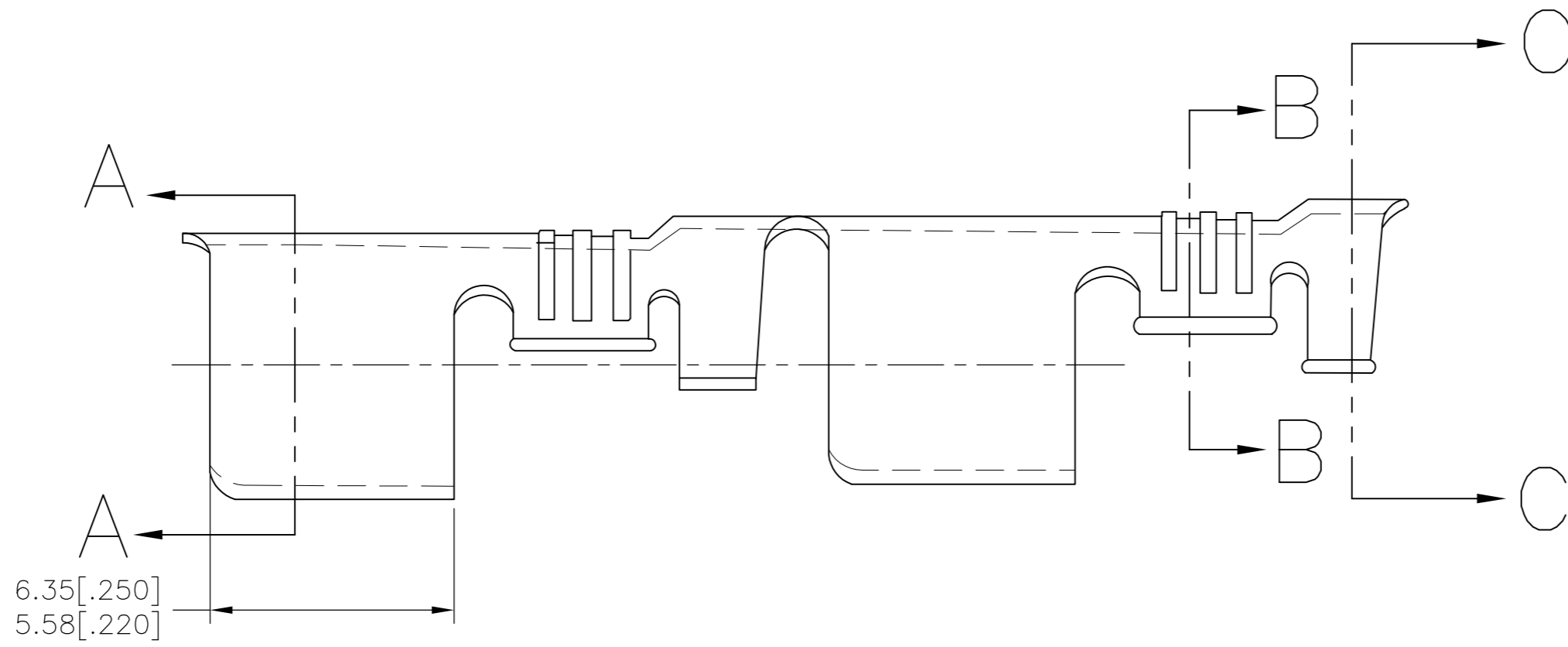

SECTION C-C
SCALE 8:1

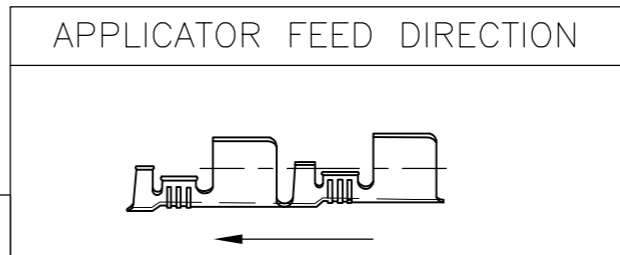

STOCK THK: 0.126 [.0126]	
CODE	MATERIAL DESCRIPTION
A	BRASS
CODE	PLATING DESCRIPTION
1	ELECTRO-TIN

THIS DRAWING IS A CONTROLLED DOCUMENT.	
DIMENSIONS: mm [INCHES]	TOLERANCES UNLESS OTHERWISE SPECIFIED:
0 PLC ± -	1 PLC ± -
2 PLC ± 0.40 [.015]	3 PLC ± 0.40 [.015]
4 PLC ± -	ANGLES ± -
MATERIAL SEE TABLE	FINISH SEE TABLE

WIRE RANGE: 20-18 INS. RANGE: Ø.090-.130		A-1 160217-2 A 160217-1 MAT. PART NO
DWN RAVI S 15NOV2016 CHK LI DAISY 15NOV2016 APVD DING TIM 15NOV2016 PRODUCT SPEC APPLICATION SPEC		TE Connectivity
NAME		PLUG
SIZE A2	CAGE CODE 00779	DRAWING NO C=160217
CUSTOMER DRAWING		RESTRICTED TO -
SCALE 4:1	SHEET 1 OF 1	REV A