

LOC	DIST	REV.	LTN	REVISIONS ÄNDERUNGEN DESCRIPTION BESCHREIBUNG	DATE	DWN	APVD
A1	-	A2		Tab.: Teil-Nr. u. Einzelteil-Nr. korrigiert	11 JUL 2002	GF	BL
		A3		update drawing	09 JAN 2003	PS	BL
		A4		NOTE 1 UPDATE	06 AUG 2003	PS	BL
		A5		NEUTRAL VERSION ADDED	02 NOV 2017	JU	HS

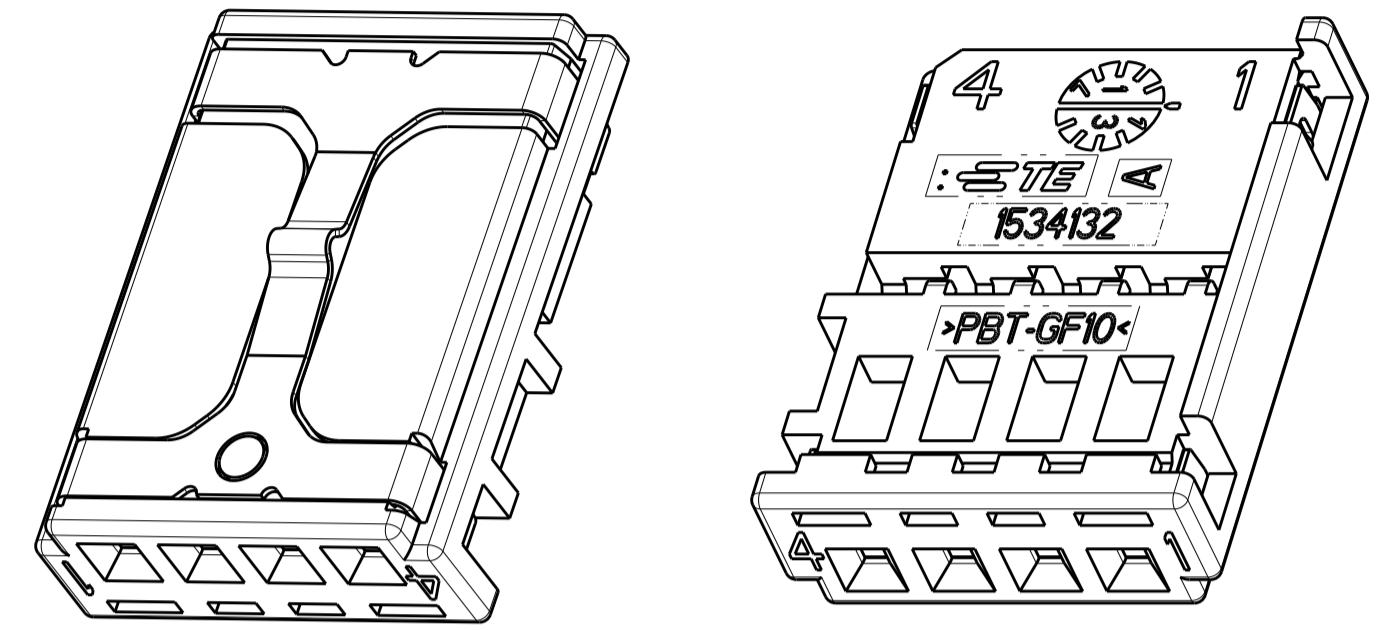

A-A

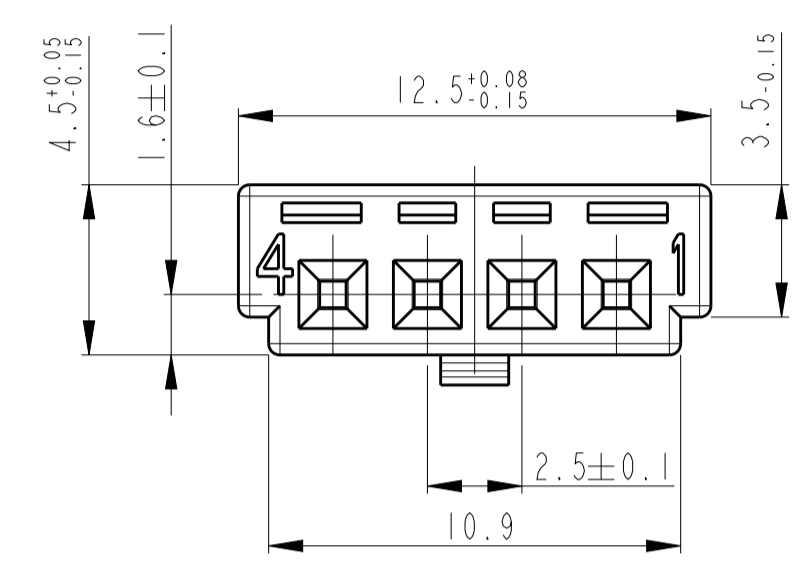
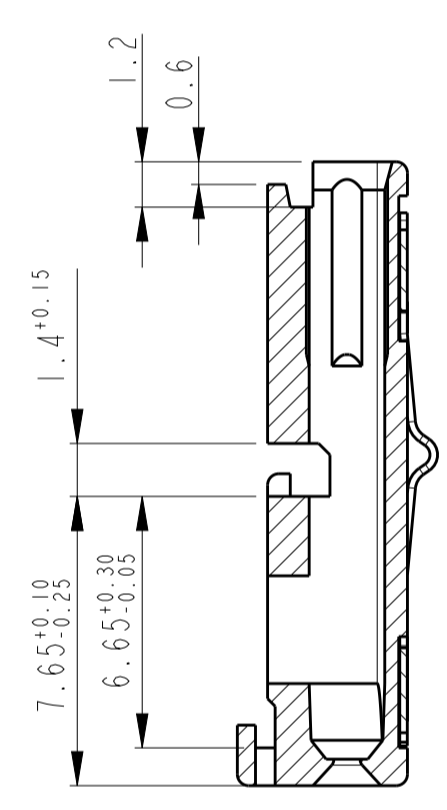
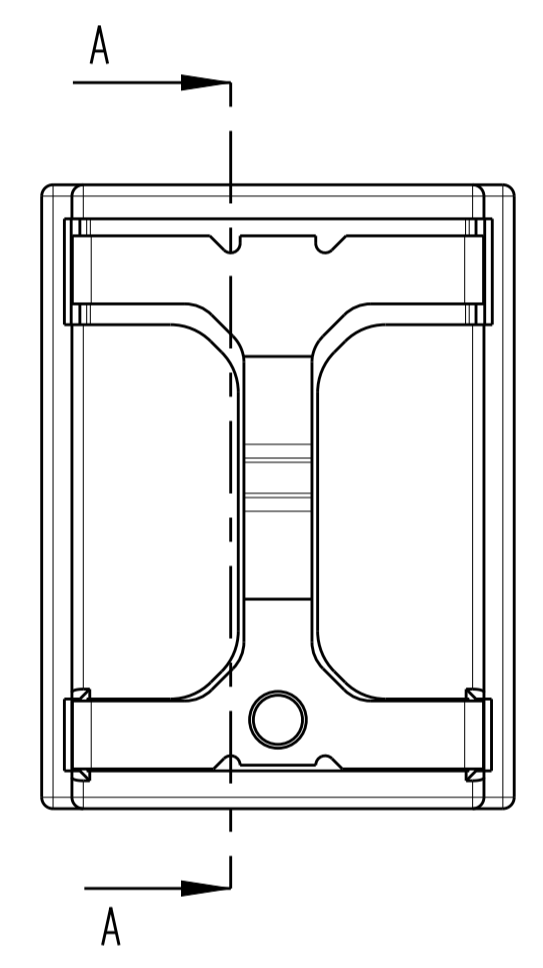
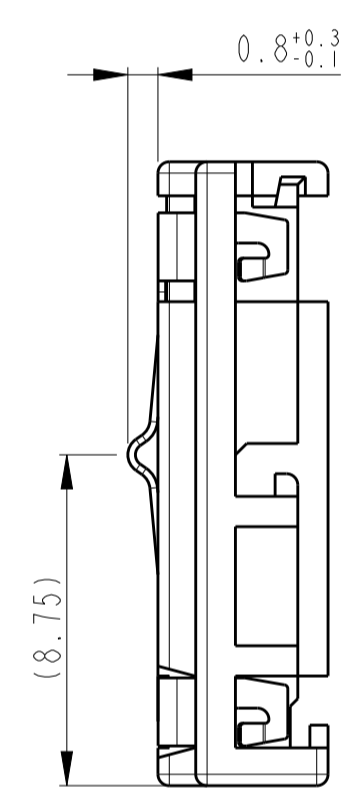
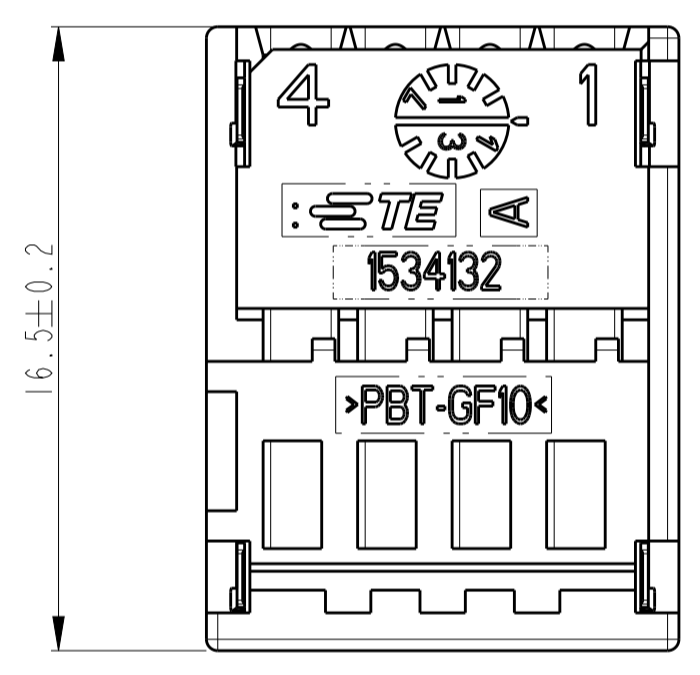
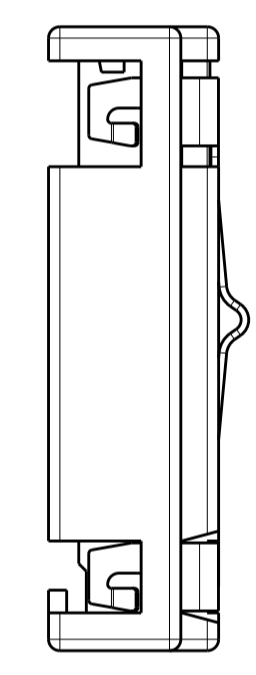

Bemerkungen

- Verwendet mit Verriegelung 1534131 nur fuer Audi  
Passender Gegenstecker 1534167 nur fuer Audi
- Nach dem Bestuecken der Kontaktkammern mit Kontakten werden Buchsengehäuse und Verriegelung zusammengesoben
- Gegenstecker nach Zeichnung 114-18490
- Passende Kontakte 1355717 (DGB 0.14 - 0.22 mm2)  
928999 (DGB 0.20 - 0.50 mm2)  
963715 (DGB 0.75 mm2)

NOTES

- USED WITH RETAINER 1534131 ONLY FOR AUDI  
SUITABLE MATING PART 1534167 ONLY FOR AUDI
- AFTER PROVIDING THE CAVITIES WITH CONTACTS HOUSING AND RETAINER WILL BE PUSHED TOGETHER
- MATING PART EXECUTION ACC. TO DRAWING 114-18490
- SUITABLE CONTACTS 1355717 (WIRE RANGE 0.14 - 0.22 mm2)  
928999 (WIRE RANGE 0.20 - 0.50 mm2)  
963715 (WIRE RANGE 0.75 mm2)

PARTS PROVIDED, BUT TILL NOW NOT ORDERED !  
 Teile vorgesehen, aber noch nicht beauftragt !

ASS'Y NO./ORDER-NO. Teil-Nr./Bestell-Nr.	REV.	ITEM NO.	PART NO. Einzelteil-Nr.	REV.	MATERIAL	COLOUR Farbe	DESCRIPTION Benennung
1-1534130-3	A	1	1534133-2	A	X12CrNi177	-	LOCKING LANCE/Rastfeder
1-1534130-1	A	1	1534132-3	A	PBT-GF10	RED/rot	REC.HSG/Bu-Geh.
			1534133-2	A	X12CrNi177	-	LOCKING LANCE/Rastfeder
			1-1534132-1	A	PBT-GF10	BLACK/schwarz	REC.HSG/Bu-Geh.

DWN	G. Fischer	08JAN02		tyco Electronics AMP GmbH
CHK	B. Kirsch	08JAN02		D - 64625 Bensheim
APVD			NAME	REC.HSG., 4 POSN., MOS, ASSY Buchsengehäuse, 4 pol., MOS, ZSB
			PRODUCT SPEC	
			APPLICATION SPEC	
			SIZE	
			WEIGHT	
			CUSTOMER DRAWING	/KUNDENZEICHNUNG