

THIS DRAWING IS UNPUBLISHED. RELEASED FOR PUBLICATION
 © COPYRIGHT - BY TYCO ELECTRONICS CORPORATION. ALL RIGHTS RESERVED.

LOC	DIST	REVISIONS					
		P	LTR	DESCRIPTION	DATE	DWN	APVD
G	02		H	REV PER ECR 09-020427	28OCT09	JR	TM

AMP
 WIRE RANGE
 22-16 AWG
 SOLID OR STRANDED

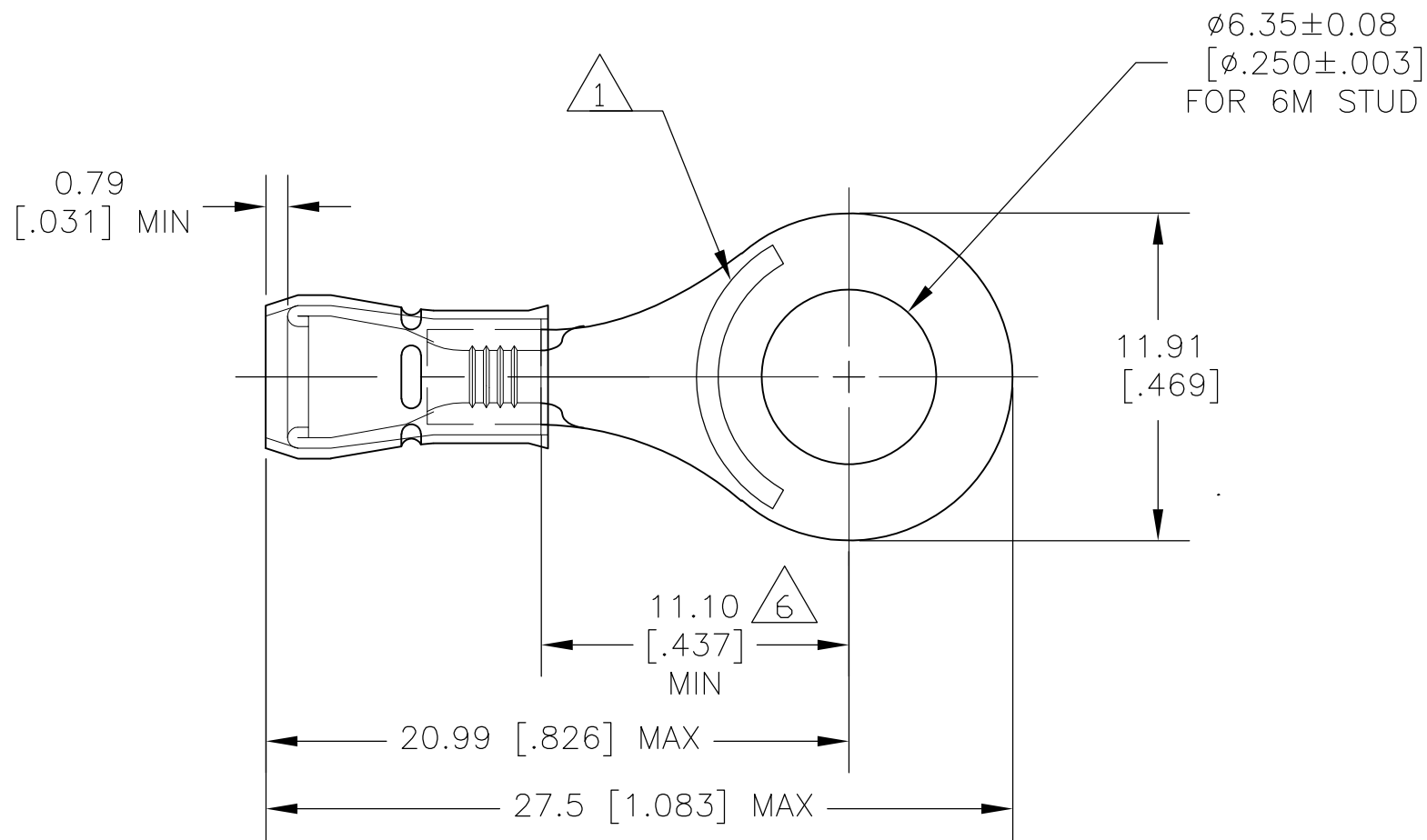

- 1 STAMP "AMP 22-18*" APPROX AS SHOWN, 22-16 TERMINALS ARE STAMPED 22-18 IN ACCORDANCE WITH MILITARY SPECIFICATION MIL-T-7928, COMMERCIAL WIRE RANGE IS 22-16.
- 2 MATERIAL: TERMINAL & SLEEVE- COPPER PER ASTM B-152, ANNEALED. INSULATION - NYLON, COLOR RED
- 3 FINISH: TERMINAL- CADMIUM PLATE PER QQ-P-416 SLEEVE- TIN PLATE PER ASTM B545
- 4 WIRE INSULATION DIA 2.0-3.2 [080-.125]
- 5 TONGUE MATERIAL THK: 0.79±0.05 [.031±.002]
- 6 DIMENSION APPLIES FROM EDGE OF WIRE BARREL TO CENTER OF STUD HOLE.
- 7 MAX RECOMMENDED OPERATING TEMP 105°C [221°F]
- 8 VOLTAGE RATING IS 300 V MAX
- 9 0.26-1.65mm² [509-3,260] CMA, STRANDED

1000	LOOSE PIECE	3	130061
QTY	PACKAGING TYPE	FINISH	PART NO

THIS DRAWING IS A CONTROLLED DOCUMENT.		DWN jr_ruth 28OCT09	Tyco Electronics Corporation Harrisburg, PA 17105-3608	
DIMENSIONS: MM [INCHES]		CHK T MICHELUTTI 28OCT09	NAME	
TOLERANCES UNLESS OTHERWISE SPECIFIED:		APVD T MICHELUTTI 28OCT09	TERMINAL, RING TONGUE, PIDG, WIRE SIZE, 22-16 AWG	
0 PLC ± -		PRODUCT SPEC	-	
1 PLC ± -		APPLICATION SPEC	-	
2 PLC ± -		WEIGHT	-	
3 PLC ± 0.20 [.008]		CUSTOMER DRAWING	SCALE 4:1	SHEET 1 OF 1
4 PLC ± -		FINISH	RESTRICTED TO	
ANGLES ± -		SEE TABLE	REV H	
MATERIAL - 2		SIZE A3	CAGE CODE 00779	DRAWING NO C-130061