

NOTE



All numerical values are in metric units [with U.S. customary units in brackets]. Dimensions are in millimeters [and inches]. Unless otherwise specified, dimensions have a tolerance of ± 0.13 [± 0.005] and angles have a tolerance of $\pm 2^\circ$. Figures and illustrations are for identification only and are not drawn to scale.

1. INTRODUCTION

This specification covers requirements for the application of AMPLIMITE HD-20 Printed Circuit (PC) Board Connectors with ACTION PIN Contacts. Plug connectors are loaded with pin contacts and receptacle connectors are loaded with socket contacts. Each connector type has contact rows that are on 2.85 mm [.112 in.] centers.

The connectors are available in shell sizes of 1, 2, 3, 4, and 5 with respective contact positions of 9, 15, 25, 37, and 50. They can be supplied with internally threaded 4-40 screwlocks or threaded inserts, or with mounting flanges that have no attaching hardware. Plug connectors with Front Metal Shells have grounding indents to enhance electrical continuity with the mating cable receptacle connector. The ACTION PIN contact design features split contact tines that fit into plated-through holes in the pc board to form a friction fit.

Figure 1 provides connector features and terms used throughout this specification. Use these terms when corresponding with TE Connectivity Representatives to facilitate assistance.

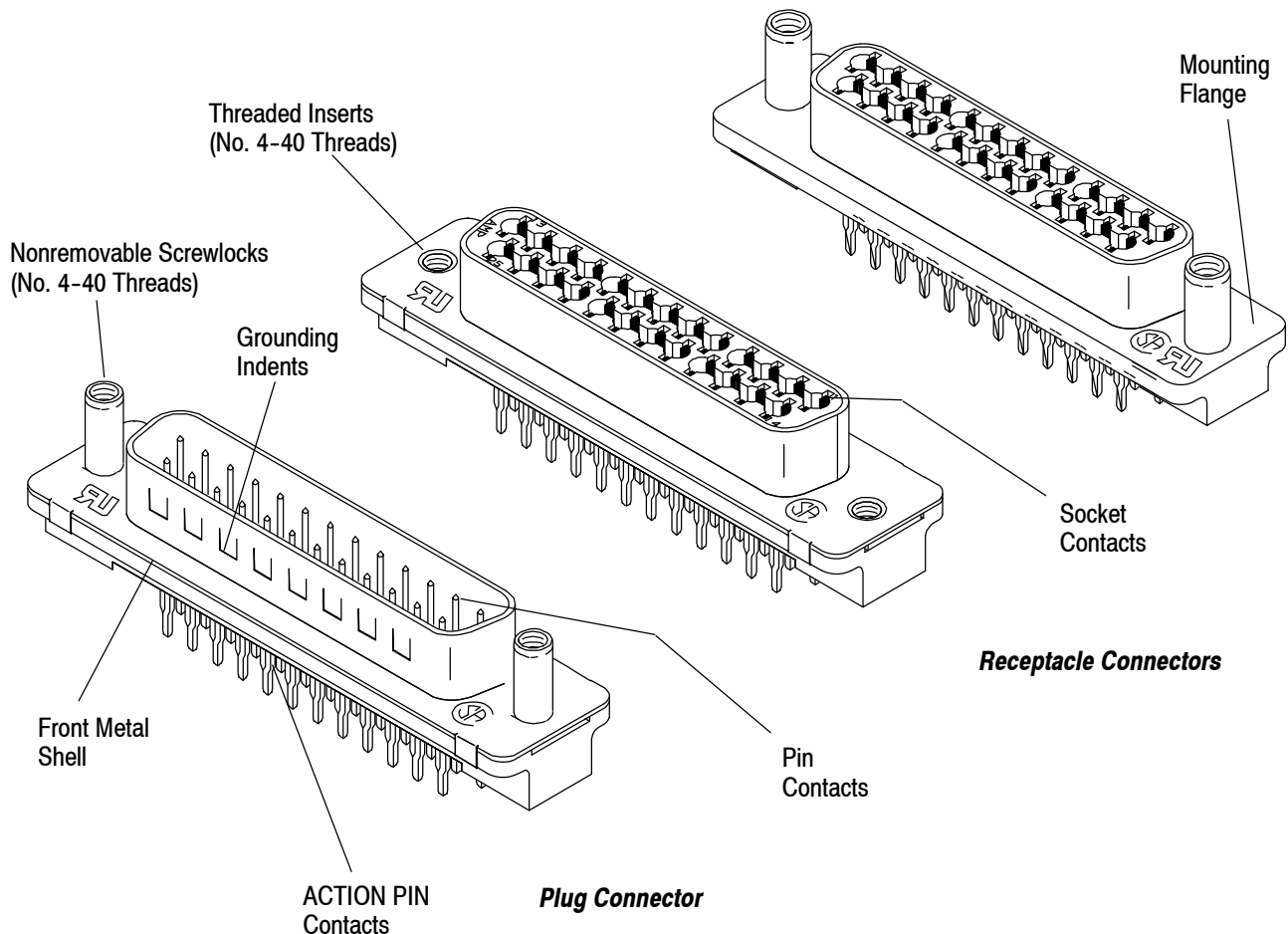

Figure 1

2. REFERENCE MATERIAL

2.1. Revision Summary

This paragraph is reserved for a revision summary covering the most recent additions and changes made to this specification which include the following:

- Changed or deleted text in title, Section 1, Paragraphs 2.2, 3.3, 3.5.A, 3.8, and Sections 4 and 6
- Added new art in Figure 1 and changed table information in Figure 6

2.2. Customer Assistance

Product Part Number 5745922 and Product Code 4913 are representative numbers of AMPLIMITE HD-20 PC Board Connectors with ACTION PIN Contacts. Use of these numbers will identify the product line and expedite your inquiries through a service network established to help you obtain product and tooling information. Such information can be obtained through a local TE Representative or, after purchase, by calling the Tooling Assistance Center or Product Information Center number at the bottom of page 1.

2.3. Drawings

Customer Drawings for product numbers are available from the service network. The information on the customer drawing and this specification takes priority over any other document supplied by TE. If there is a conflict with the information on the customer drawing and this specification call either of the customer service numbers at the bottom of page 1 for assistance.

2.4. Specifications

Product Specification 108-40014 covers test and performance requirements.

2.5. Instructional Material

The following instruction material covers the application and maintenance of tooling that is recommended for seating plug and receptacle connectors on the pc board.

A. Instruction Sheets

- 408-6889 Repair Tool Kit
- 408-9031 Receptacle Seating Tools
- 408-9293 Plug Seating Tools

B. Customer Manuals

- 409-5626 Bench Machine Power Unit
- 409-5567 Floor Model Power Unit

3. REQUIREMENTS

3.1. Storage

A. Ultraviolet Light

Prolonged exposure to ultraviolet light may deteriorate the chemical composition used in connectors.

B. Shelf Life

The connectors should remain in the shipping containers until ready for use to prevent damage. They should be used on a first in, first out basis to avoid storage contamination that could adversely affect signal transmissions.

C. Chemical Exposure

Do not store connectors near any chemicals listed below, as they may cause stress corrosion cracking in the components.

Alkalies	Ammonia	Cittrates	Phosphates Citrates	Sulfur Compounds
Amines	Carbonates	Nitrites	Sulfur Nitrites	Tartrates

3.2. Connector Shell Sizes

There are five industry standard shell sizes available for these connectors. A composite of receptacle shell sizes and the overall dimension for each is provided in Figure 2.

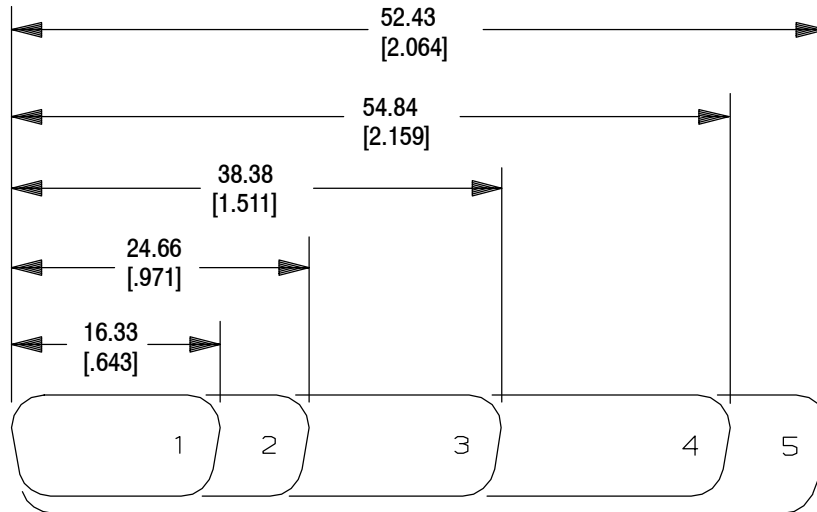

Receptacle Shell Sizes

Figure 2

3.3. Panel Mount Cutout

We recommend panel-mounting for all AMPLIMITE HD-20 PC Board Connectors with ACTION PIN Contacts. Dimensions of correct placement of connectors in a panel are provided in Figure 3.

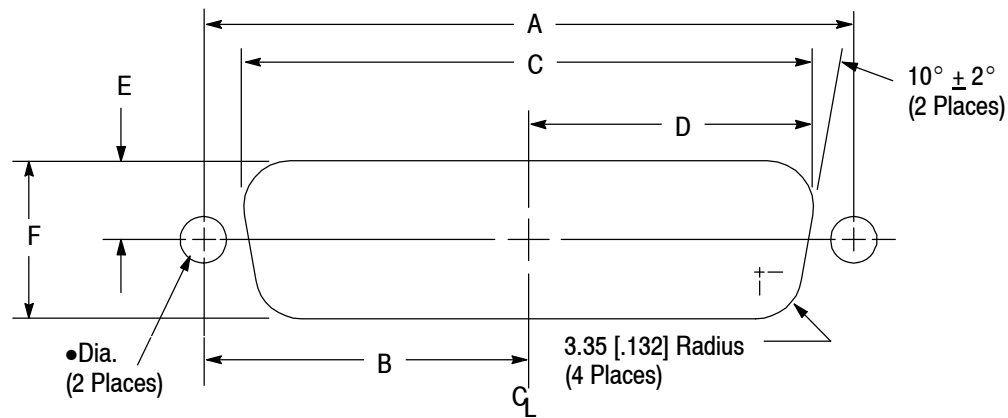

- 4.83 [.190] For Use With Nonremovable Screwlocks; 3.05 [.120] For Use With Removable Screwlocks

SHELL SIZE (NO. of POSITIONS)	DIMENSIONS					
	A	B	C	D	E	F
1 (9)	24.99 [.984]	12.50 [.492]	20.47 [.806]	10.24 [.403]	5.72 [.225]	11.4 [.449]
2 (15)	33.32 [1.312]	16.66 [.656]	28.8 [1.134]	14.4 [.567]	5.72 [.225]	11.4 [.449]
3 (25)	47.04 [1.852]	23.52 [.926]	42.52 [1.674]	21.26 [.837]	5.72 [.225]	11.4 [.449]
4 (37)	63.50 [2.500]	31.75 [1.250]	59.08 [2.326]	29.54 [1.163]	5.72 [.225]	11.4 [.449]
5 (50)	61.11 [2.406]	30.56 [1.203]	56.34 [2.218]	28.17 [1.109]	7.06 [.278]	14.1 [.555]

Figure 3

3.4. Mating

The distance between the mated connector flanges must be considered when determining the method of mounting to assure full mating of the connectors. The panel thickness and mounting hole location on the panel must also be considered to avoid interference when the connector is mounted to a panel. The required dimension between mounting flanges is provided in Figure 4.

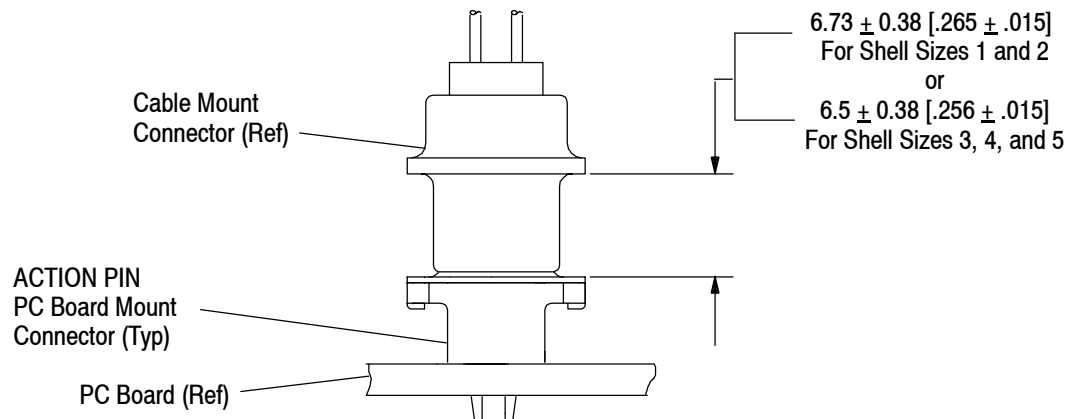

Figure 4

3.5. Printed Circuit Board

A. PC Board Thickness

Connectors are available for use in pc board thicknesses of 1.57 mm [.062 in.] minimum and 2.36 mm [.093 in.] minimum.

B. PC Board Layout

The specific pc board layout for each connector size is provided in Figure 5. The contact holes must be plated through and the connectors seated on the pc board with tooling specifically designed for the connector size. Details of the plated-through holes and tooling references follow the pc board layouts.

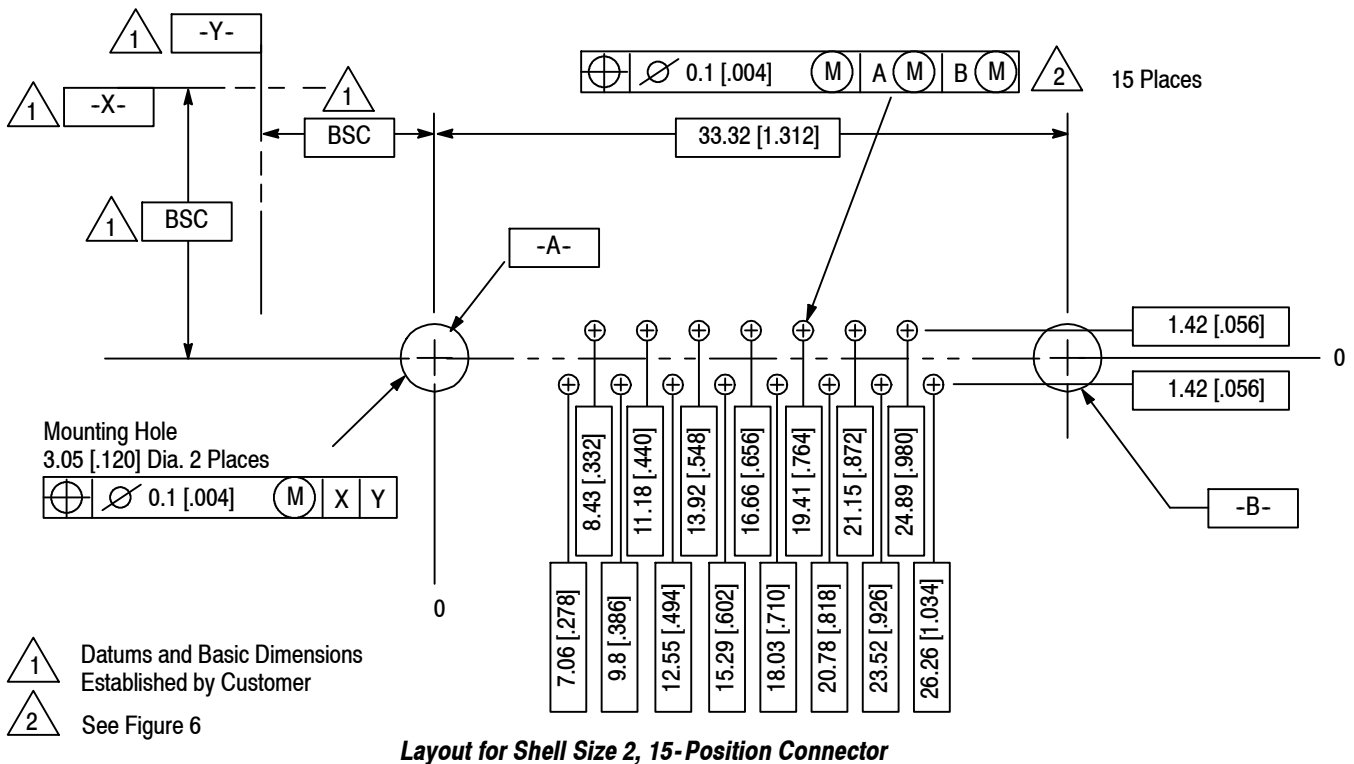
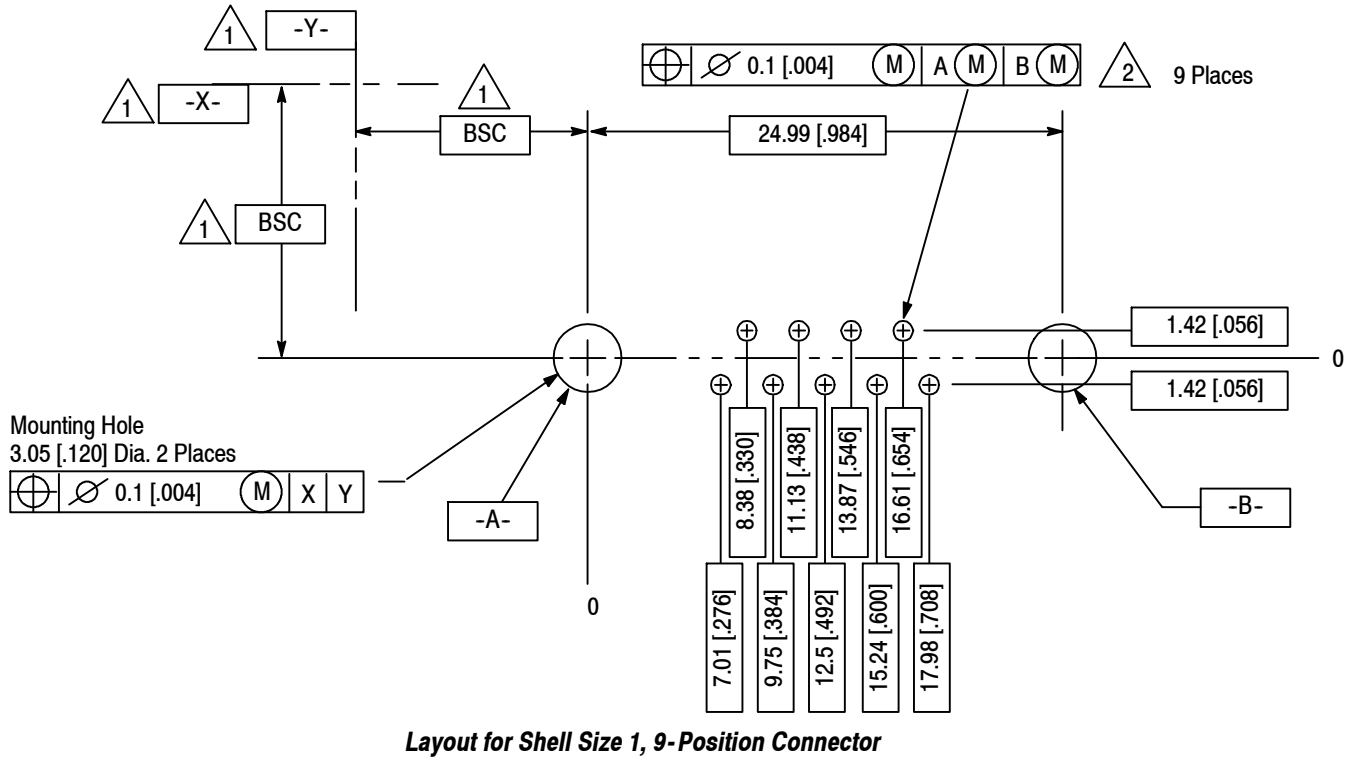
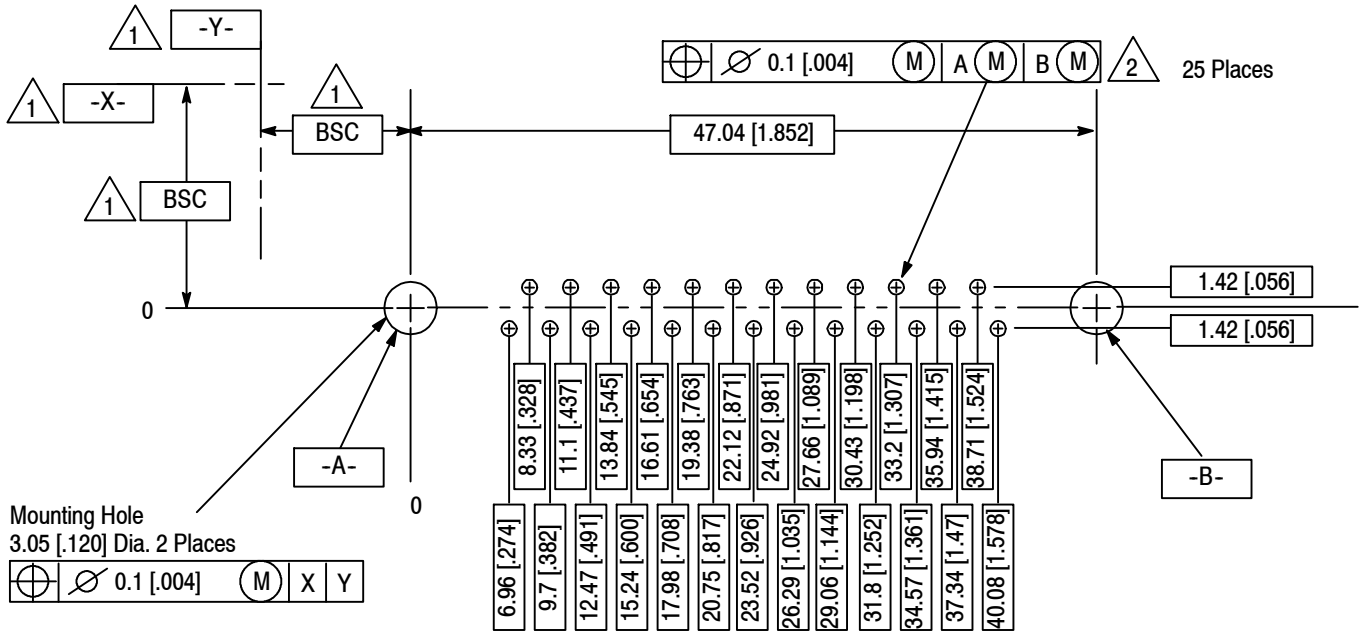
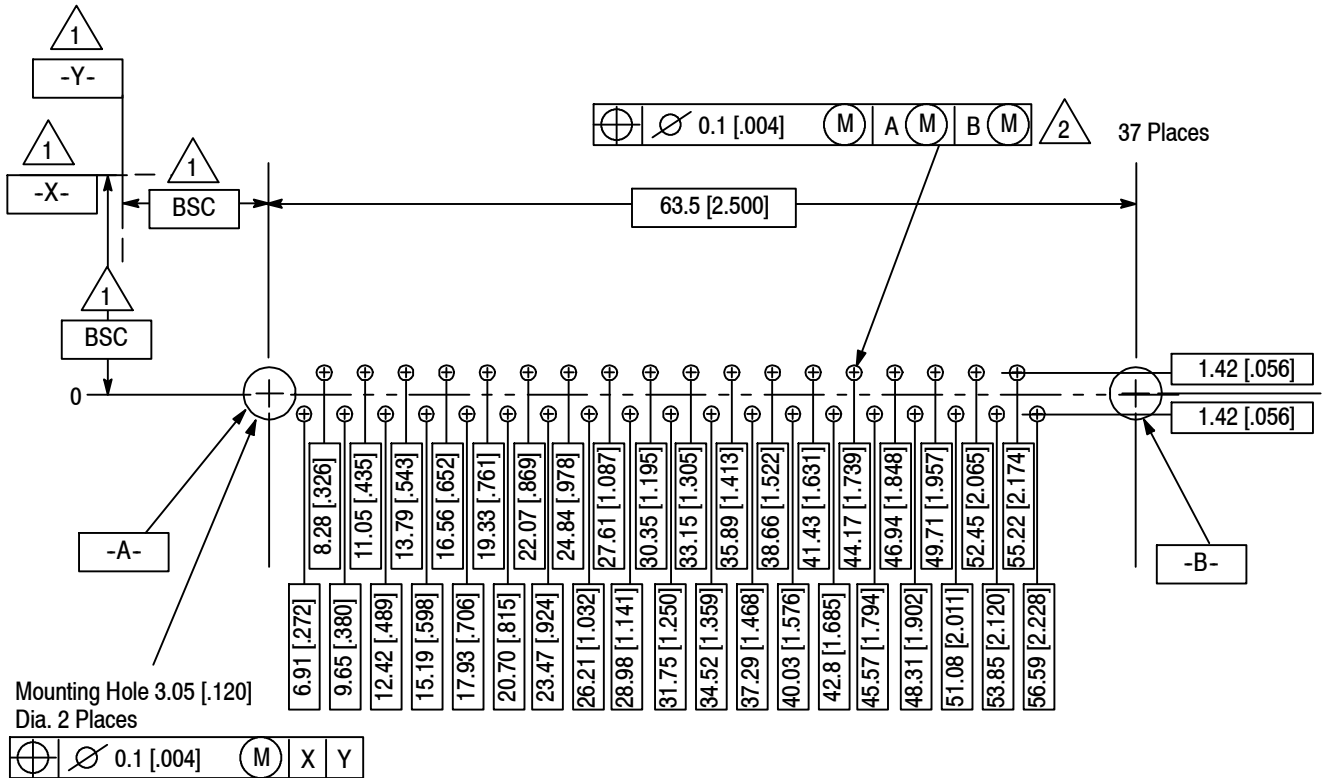

Figure 5 (cont'd)



Layout for Shell Size 3, 25-Position Connector



Layout for Shell Size 4, 37-Position Connector

1 Datums and Basic Dimensions Established by Customer

2 See Figure 6

Figure 5 (cont'd)

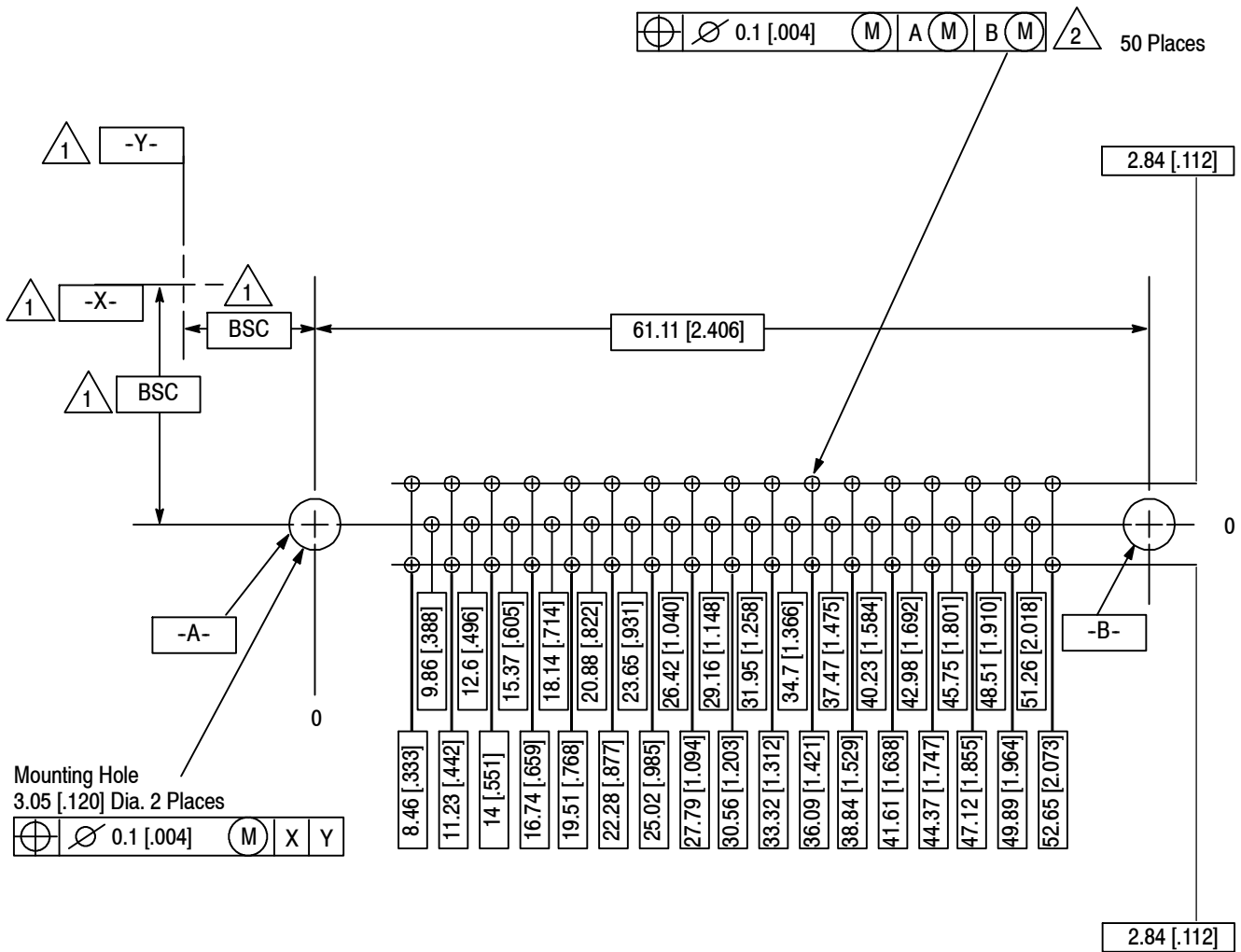

Layout for Shell Size 5, 50-Position Connector

- Datum and Basic Dimensions Established by Customer
- See Figure 6

Figure 5 (end)

C. Plated-Through Hole Dimensions

ACTION PIN Contacts make a gas-tight, press-fit connection when correctly applied in plated-through holes. Accurate hole diameters and plating thicknesses must be maintained to assure optimum performance. Plated-through hole dimensions are provided in Figure 6.

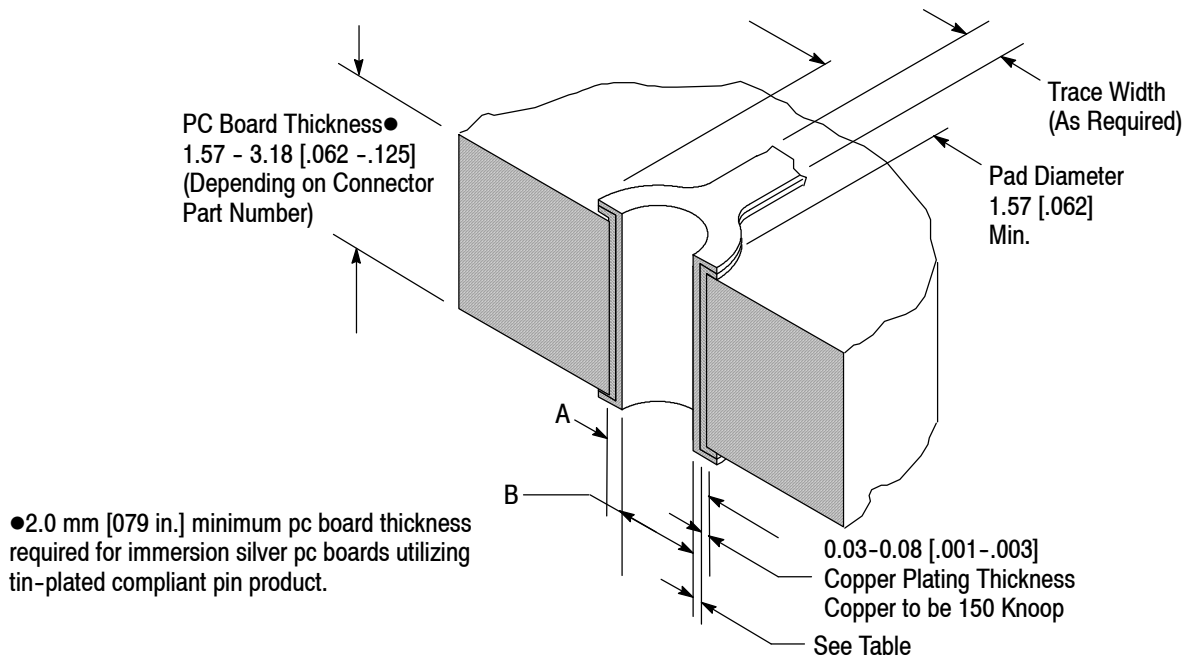

PC BOARD HOLE

DRILLED HOLE DIAMETER A	HOLE DIA AFTER PLATING • (B)	SURFACE FINISH	
		PLATING	THICKNESS
1.151 ±0.025 [0.0453 ±0.0010]	1.02 [0.040]	Hot Air Solder Leveling (HASL) Tin-Lead (Sn-Pb)	0.008 [0.0003] Min
1.151 ±0.025 [0.0453 ±0.0010]	1.02 [0.040]	Immersion Tin (Sn)	0.0005-0.004 [0.000020-.000160]
1.151 ±0.025 [0.0453 ±0.0010]	1.02 [0.040]	Organic Solderability Preservative (OSP)	0.0002-0.0005 [0.000008-.000020]
1.176 ±0.025 [0.0463 ±0.0010]	1.04 [0.041]	Immersion Gold (Au) over Nickel (Ni) (ENIG)	0.0001-0.0005 [0.000004-.000020] Au, 0.00127-0.0076 [0.00005-.00030] Ni
1.151 ±0.025 [0.0453 ±0.0010]	1.02 [0.040]	Immersion Silver (Ag)	0.0001-0.0005 [0.000004-.000020]

•Dimension is provided for reference only. The drilled hole diameter is critical and must be maintained within specified tolerance for proper application.

Figure 6

3.6. Polarizing and Keying

The keystone configuration of this connector's mating face prohibits the accidental inversion of mating connectors. To prevent mismatching of same size connectors, keying plugs may be placed in receptacle connectors as indicated in Figure 7.

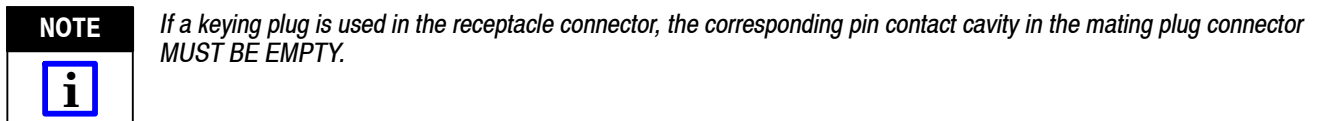

Figure 7

3.7. Hardware

The use of hardware is recommended to ensure mated connectors will remain securely attached under all operating conditions. The torque value for securing hardware will depend on the type of connector attachment. See Figure 8.

A. Connectors with Screwlocks

Mounting hardware used to secure cable connectors to pc board connectors that have screwlocks must not exceed the torque value of 0.23 N•m [2 in-lb].

B. Connectors with Threads in Flanges

Mounting hardware used to secure connectors to pc board mounted connectors that have mounting flanges with threaded inserts must not exceed the torque value of 0.45 N•m [4 in-lb].

Connector with 4-40 Threaded Insert Using Removable Short Female Screwlocks

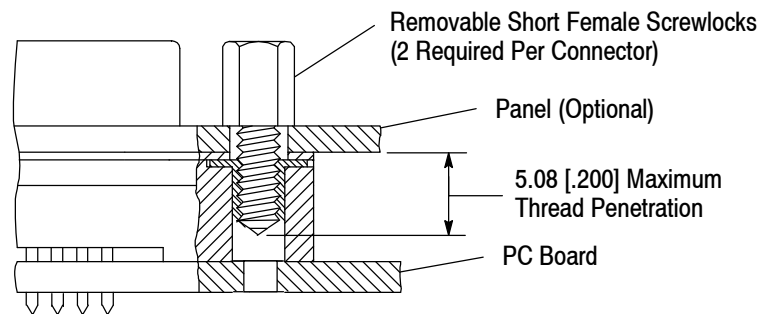

Connector with 4-40 Fixed Female Screwlocks

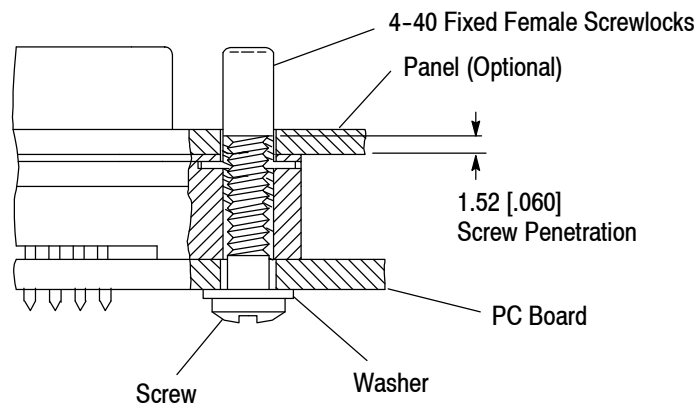

Connectors With Integral Hardware

Connector with Standard Mounting Holes Using Removable Long Female Screwlock Kit

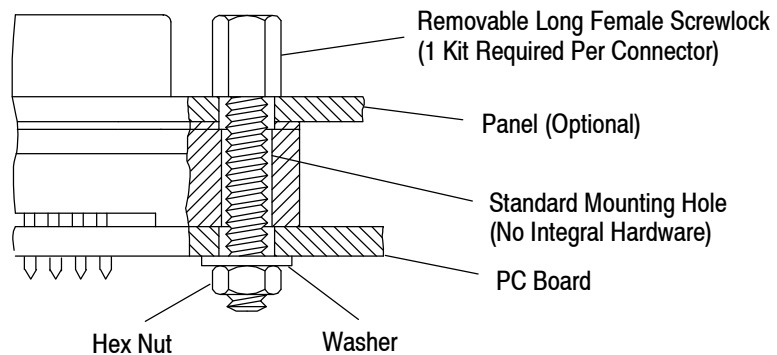

Connectors Without Integral Hardware

Figure 8

3.8. Shielding

Tin plated connectors with Front Metal Shells provide continuity for EMC (Electromagnetic Compatibility) applications.

When AMPLIMITE HD-20 Front Metal Shell PC Board Connectors with ACTION PIN Contacts are mated with corresponding metal shell connectors, grounding continuity and shielding are achieved. Use of screws and nuts through connector flanges into the pc board provide additional electrical continuity.

4. QUALIFICATIONS

The AMPLIMITE HD-20 PC Board Connectors containing ACTION PIN Contact are Listed in Underwriters Laboratories Inc. (UL), File E81956; and are Certified by CSA International in File LR 7189.

5. TOOLING

A connector specific seating tool and a pc board support are the basic tools needed to install these connectors into a pc board. The power source used to install the connectors must be capable of providing 178 Newtons [40 pounds] of force for each contact to be installed. TE has existing seating tools and power units to apply these connectors. Part numbers of available tools and the applicable instructional material are provided in Figure 9.

5.1. Seating Tool

Seating tools are designed to push evenly on the connector and force the ACTION PIN Contacts into the pc board. There are two basic designs; one design is for plug connectors and the other is for receptacle connectors. Each of the basic designs is available in five sizes to accommodate the five connector shell sizes. See Figure 9.

5.2. PC Board Support

A pc board support (customer supplied) must be used to prevent bowing of the pc board during insertion of the connectors. It should have a flat surface with holes or a channel large enough to receive the ACTION PIN contacts during installation. See Figure 9.

5.3. Arbor Frame Assembly

Manually operated, commercially available arbor frame assemblies capable of providing 178 Newtons [40 pounds] of force per contact can be used with the seating tools and support plate to install small quantities of connectors.

5.4. SM-3 Bench Machine Power Unit

Power operated SM-3 Bench Machines can be used with the seating tools and support plate to install connectors into pc boards within the size of 457.2 x 609.6 mm [18 x 24 in.].

5.5. H-Frame Power Unit

Power operated H-Frame Floor Model Machines can be used with the seating tools and support plate. It can be used to install large quantities of connectors in pc boards of all sizes and shapes.

5.6. Repair Tool

A repair tool kit consisting of a spring-loaded impact tool handle assembly, a removal tip, and a replacement tip is available for removing damaged compliant pin contacts and replacing them with new ones. The housing must be supported and the contact must be free to back out of housing with a suitable housing support that will not damage housing.

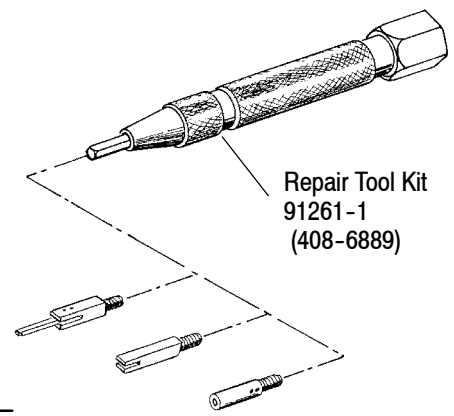
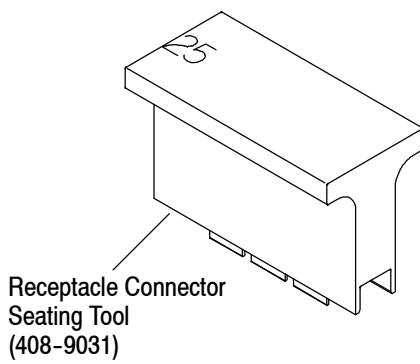
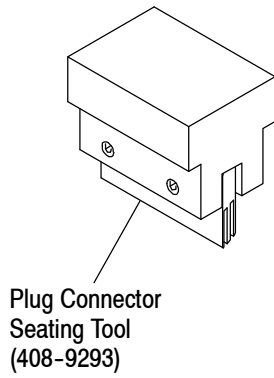

SHELL SIZE	NO. OF POSITIONS	CONNECTOR SEATING TOOLS	
		RECEPTACLE	PLUG
1	9	91164-2	58274-3
2	15	91165-2	58274-6
3	25	91168-2	58274-1
4	37	91166-2	58274-5
5	50	91167-2	58273-1

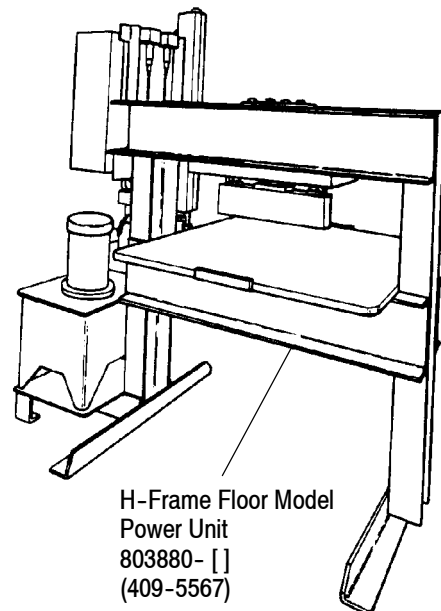
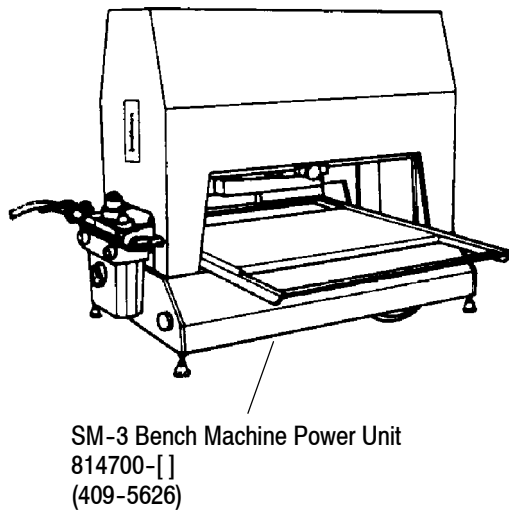
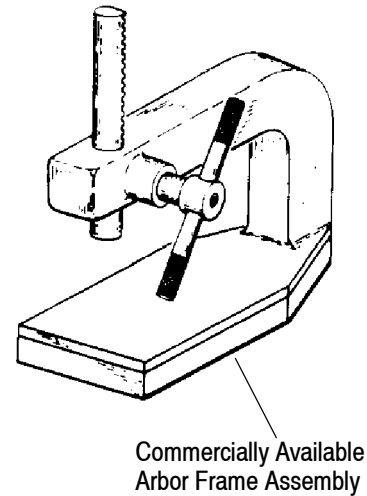
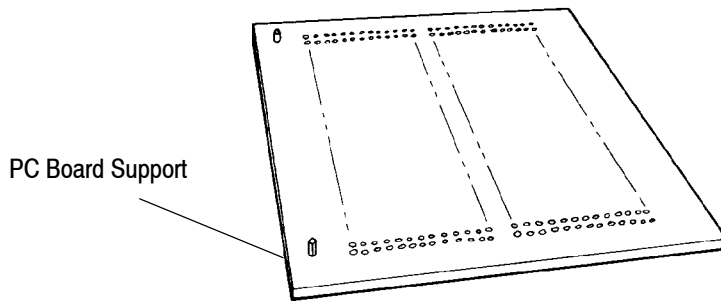

Figure 9

6. VISUAL AID

Figure 10 shows a typical installation application of AMPLIMITE HD-20 Connectors with ACTION PIN Contacts and should be used by production personnel to ensure a correctly applied product. Applications which DO NOT appear correct should be inspected using the information in the preceding pages of this specification.

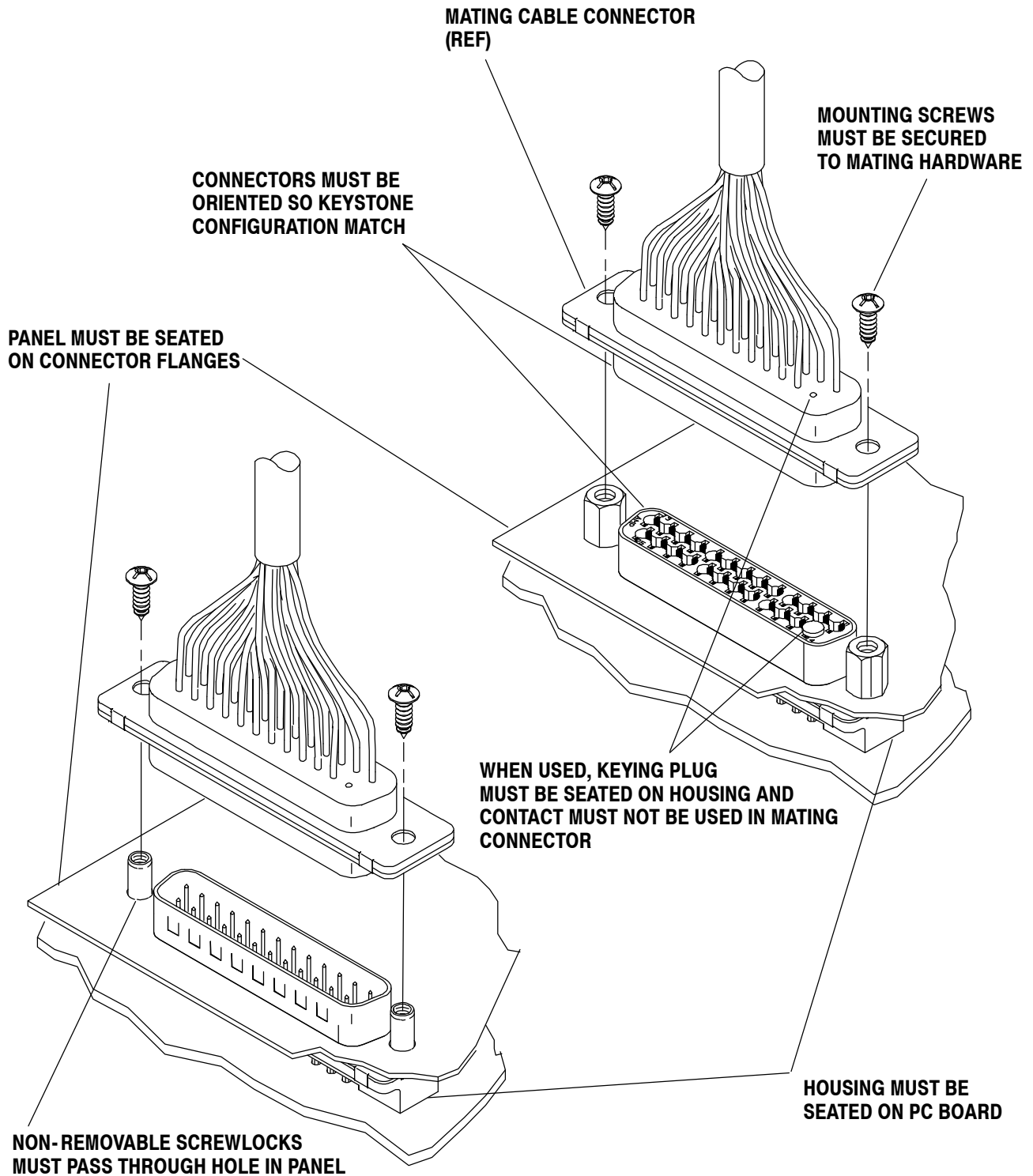

FIGURE 10. VISUAL AID