



NOTE

All numerical values are in metric units [with U.S. customary units in brackets]. Dimensions are in millimeters. Unless otherwise specified, dimensions have a tolerance of ± 0.13 and angles have a tolerance of $\pm 2^\circ$. Figures are for identification only and are not drawn to scale.

1. INTRODUCTION

This specification covers the requirements for application of the LUMAWISE Z50 (Type LK) LED holder for Philips Lumileds LUXEON K LED with 12 or 16 emitter arrays. The LED holder allows direct attachment of the LED to a cooling device using two customer-supplied M3x6-mm (minimum depth) or No. 4-40 mounting screws and provides poke-in termination to electrically connect the LED. The LED holder is available in low profile and Zhaga-compliant form-factor profile.

The LED holder contains two poke-in contacts that each accept stranded, solid, or fused wire sizes 22, 20, and 18 AWG and two LED contacts. The LED holder features an LED opening with two tear-drop shaped clamp features, two wire entrance holes, and two screw holes that each accept a screw for mounting. The LED opening accepts the LED, and the clamp features hold it in place. LED polarity indicators that correspond to each wire entrance hole are embossed on the top and bottom of the LED holder to indicate the orientation of the LED. The two optic attachments enable direct attachment of secondary optics.

When corresponding with personnel, use the terminology provided in this specification to facilitate your inquiries for information. Basic terms and features of this product are provided in Figure 1.

LED Holder (Zhaga-Compliant Form-Factor Profile Shown)

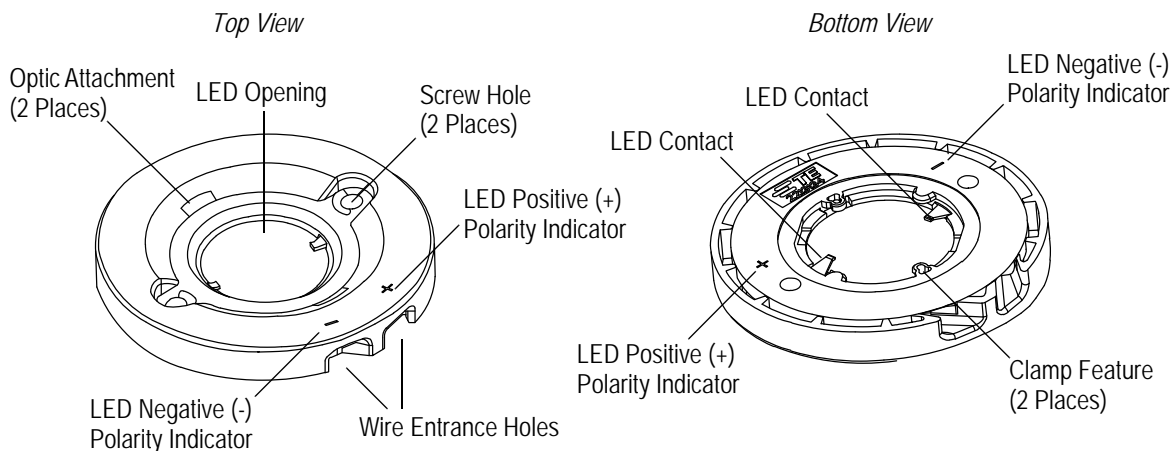

Figure 1

2. REFERENCE MATERIAL

2.1. Revision Summary

Revisions to this application specification include:

- Added name to product
- Added Paragraph 3.4 and Figure 3, and modified current Paragraph 3.6
- Added Step 4 to current Paragraph 3.7, and added file number to Section 4

2.2. Customer Assistance

Reference Product Base Part Number 2213134 and Product Code L836 are representative of LUMAWISE Z50 (Type LK) LED holder for Philips Lumileds LUXEON K LED. Use of these numbers will identify the product line

Zhaga is a trademark.

and help you to obtain product and tooling information. Such information can be obtained through a local Representative, by visiting our website at www.te.com, or by calling PRODUCT INFORMATION or the TOOLING ASSISTANCE CENTER at the numbers at the bottom of page 1.

2.3. Drawings

Customer Drawings for product part numbers are available from the service network. If there is a conflict between the information contained in the Customer Drawings and this specification or with any other technical documentation supplied, call PRODUCT INFORMATION at the number at the bottom of page 1.

2.4. Specifications

Product Specification 108-133009 provides product performance and test information.

2.5. Instructional Material

Instruction Sheets (408-series) provide product assembly instructions. There are no instruction sheets available that pertain to this product.

3. REQUIREMENTS

3.1. Safety

Do not stack product shipping containers so high that the containers buckle or deform.

3.2. Storage

The LED holder should remain in the shipping container until ready for use to prevent deformation to the contacts. The LED holders should be used on a first in, first out basis to avoid storage contamination that could adversely affect performance.

3.3. Wire Selection and Preparation

The LED holder accepts stranded, solid, or fused wire sizes 22, 20, and 18 AWG. It is recommended to use Underwriters Laboratories Inc. (UL) Appliance Wiring Material (AWM) Style 1007. The wire must be stripped within the dimensions provided in Figure 2.



CAUTION

Wire conductors must not be nicked, cut, or scrapped during or after the stripping operation.

For stranded wire, it is recommended to NOT twist the strands after stripping the insulation.



CAUTION

Stranded wire should be straight (or slightly twisted), as when the wire was manufactured, for ease in inserting the wire into the socket wire entrance hole.

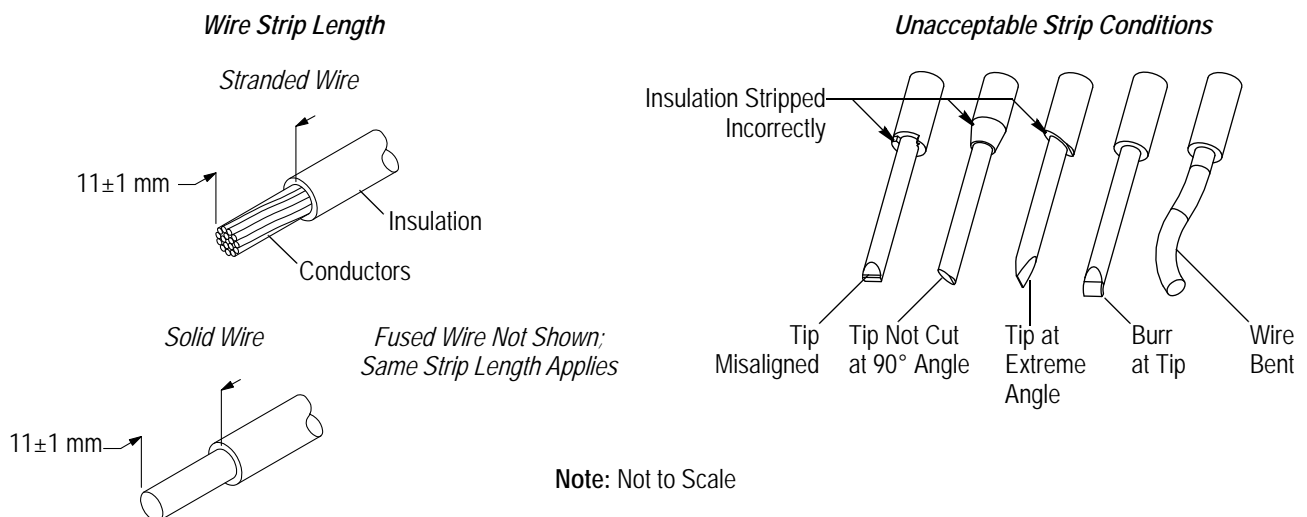

Figure 2

3.4. Customer-Supplied Thermal Interface Material (TIM) and LED

For this LED holder, it is recommended to install a paste or phase-change type TIM. For optimal TIM selection, the physical behavior at extreme temperature, mechanical versus thermal performance, heat sink choice and quality, and thermal requirements from the LED manufacturer must be considered. In addition, the TIM and LED must meet the following requirements:

- the TIM must cover the area between the LED and heat sink
- the LED protrusion, including the TIM, must not be less than 0.05 mm and not more than 0.35 mm (refer to Figure 3)

i **NOTE**
It is permissible for the LED holder to bend slightly due to the protrusion.

- the TIM and LED must have a total stack be between 0.85 and 1.5 mm (depends on selected TIM and LED)

After the LED holder is assembled, the TIM can be placed on the LED holder or on the cooling device.

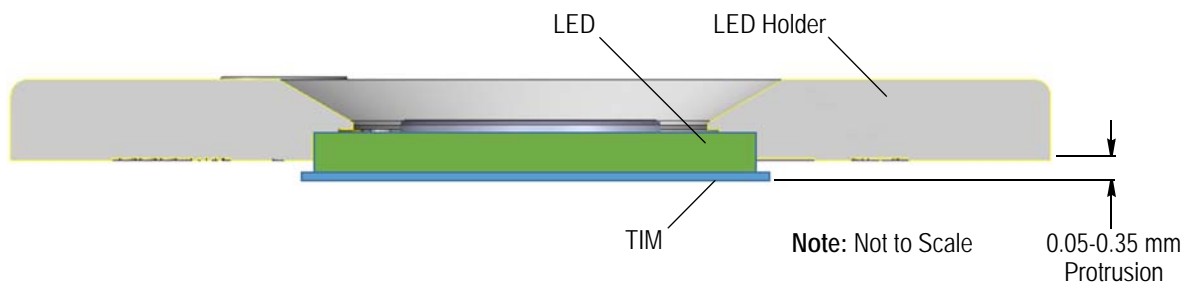

Figure 3

3.5. Customer-Supplied Mounting Screws

The mounting screws must be size M3x6-mm (minimum depth) or No. 4-40. It is recommended using screws having a head shape as the ones given in Figure 4. The flat head and oval head, which have no horizontal contact zone toward the LED holder, must not be used.

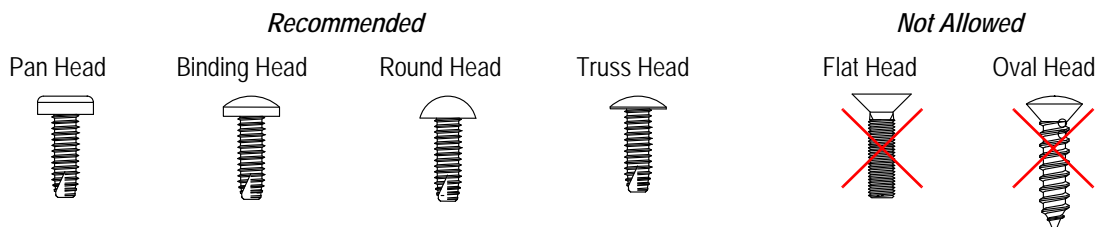
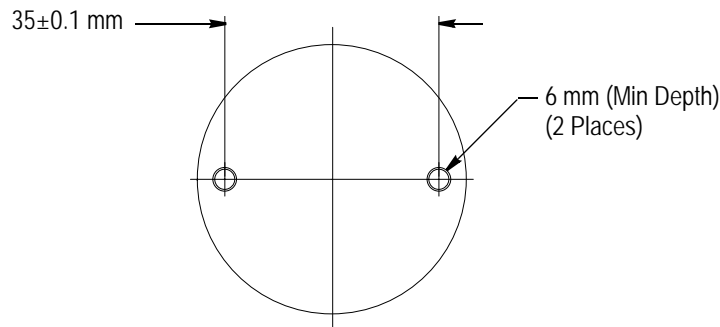

Figure 4

3.6. Mounting Hole Pattern

The cooling device must be clean and flat with no crowns or peaks in the mounting area. The recommended mounting hole pattern (not to scale) is provided on the customer drawing for the LED holder and is shown in Figure 3.

After the holes are drilled and tapped, the surface must be cleaned with isopropyl alcohol. A thermal interface material must be applied to the LED area of the cooling device according to instructions provided by Philips Lumileds.



Note: Not to Scale

Figure 5

3.7. Assembly



CAUTION

The LED holder is designed for use in a ventilated environment that allows volatile organic compound (VOC) escaping. To avoid damage to the LED, reflection of LED light from a diffuser directly onto the surface of the LED holder must be prevented as much as possible.

1. The LED must be positioned in the LED opening from the bottom side of the LED holder so that the edges of the LED are against the clamp features. The LED polarity indicators must be observed when orienting the LED into the LED opening. Then, the LED must be inserted until the clamp features hold it in place. See Figure 6, Details A and B.



CAUTION

To avoid damage to the LED, the LED must be properly positioned and seated in the LED holder. If not, the LED could crack when mounting the LED holder to the cooling device.

2. The LED holder (bottom side) must be placed on the cooling device so that the screws holes align over the holes in the cooling device. The LED holder must be secured to the cooling device using two customer-supplied mounting screws. Each mounting screw should be tightened to a torque between 0.4 and 0.6 Nm [3.54 and 5.31 in.-lb]. See Figure 6, Detail C.
3. The stripped end of each wire must be inserted into a wire entrance hole of the LED holder until it bottoms in the LED holder. See Figure 6, Details D and E.
4. If using a TIM, place the TIM on the LED holder or cooling device.

3.8. Removal

The LED holder can be removed from the cooling device by removing the customer-supplied mounting screws.

3.9. Replacement and Repair

Defective or damaged LED holders must not be used. The LED holder must not be re-used by removing the wires. The maximum removal cycle for the mounted LED holder is 5 times without removing the wires from the LED holder.

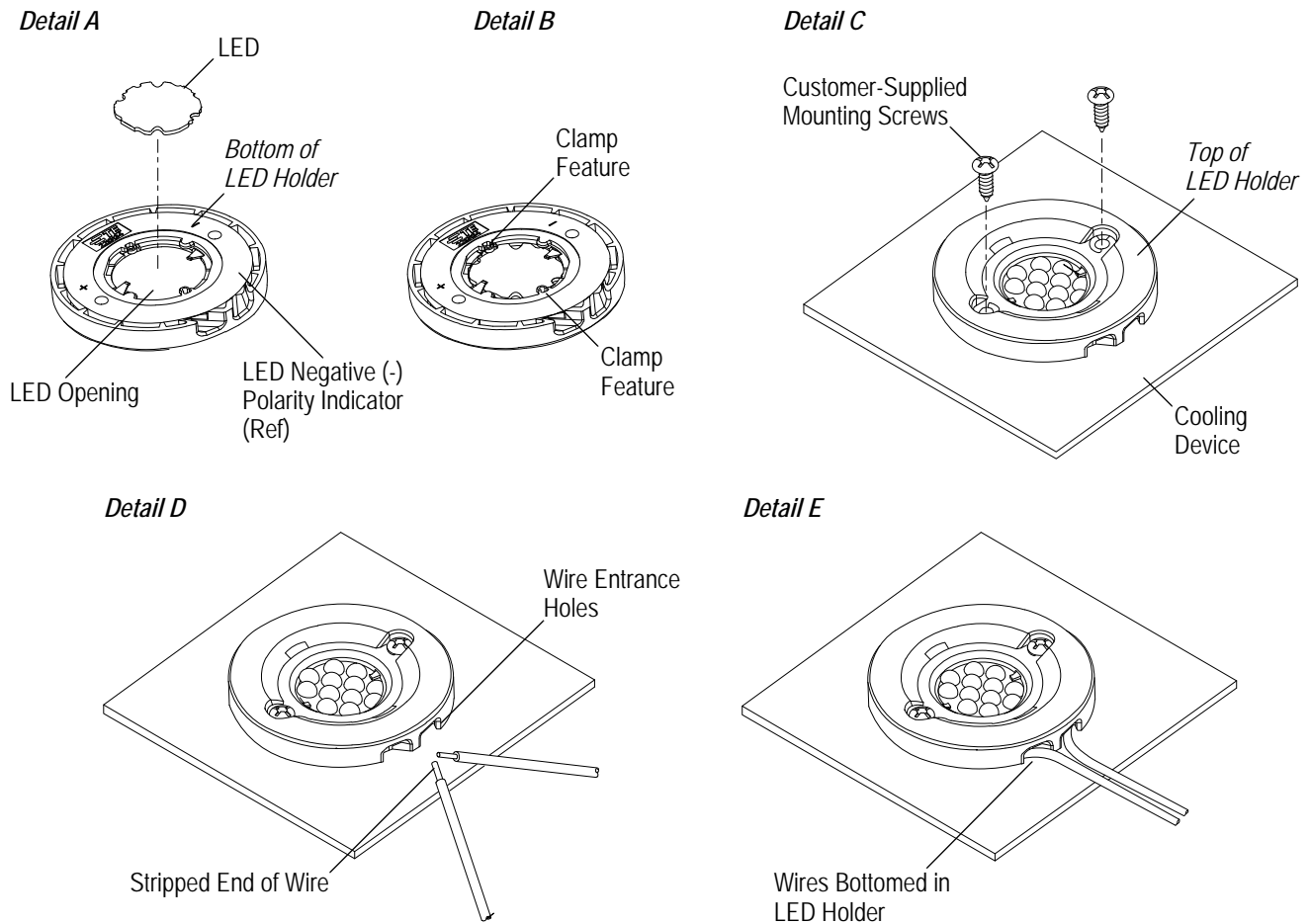

Figure 6

4. QUALIFICATION

LUMAWISE Z50 (Type LK) LED holder is Listed by Underwriters Laboratories Inc. (UL) in File E28476.

5. TOOLING

A standard screwdriver is required to tighten the customer-supplied mounting screws for mounting the LED holder to the cooling device.

6. VISUAL AID

The illustration below shows a typical application of LUMAWISE Z50 (Type LK) LED holder for Philips Lumileds LUXEON K LED. This illustration should be used by production personnel to ensure a correctly applied product. Applications which DO NOT appear correct should be inspected using the information in the preceding pages of this specification and in the instructional material shipped with the product or tooling.

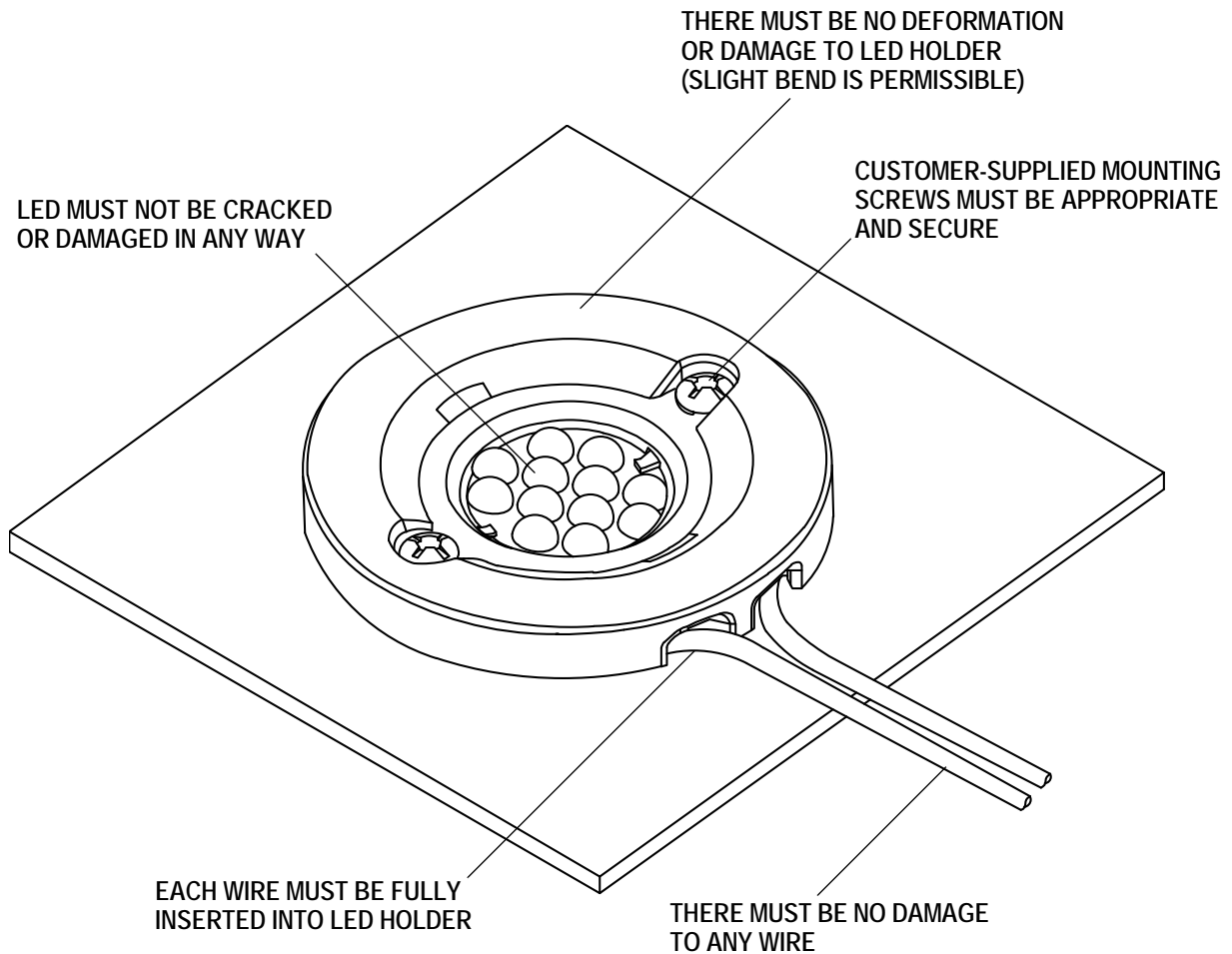

FIGURE 7. VISUAL AID