

Universal Retention Modules
NOTE

All numerical values are in metric units [with U.S. customary units in brackets]. Dimensions are in millimeters [and inches]. Unless otherwise specified, dimensions have a tolerance of ± 0.13 [± 0.005] and angles have a tolerance of $\pm 2^\circ$. Figures and illustrations are for identification only and are not drawn to scale.

1. INTRODUCTION

This specification covers the requirements for application of Universal Retention Modules (URM) for 1 mm [.039 in.] Standard Edge Connectors on 1 mm [.039 in.] centers of a printed circuit (pc) board. These folding modules are used for mechanical support for the Single Edge Contact Cartridge (SECC and SECC2); and the Single Edge Processor Package (SEPP). The modules have folding extensions for shipment of pc boards. The modules can be used without the extensions for SECC2 or SEPP processors.

The modules are attached to a pc board using plastic locking pins for 4.04 mm [.159 in.] holes; stepped plastic locking pins for 3.56 mm [.140 in.] holes; number 4 self-tapping screws for 3.56 and 4.04 mm [.140 and .159 in.] holes; and number 6 machine screws for 0.20 mm [.008 in.] through holes.

When corresponding with Tyco Electronics Personnel, use the terminology provided on this specification to help facilitate your inquiry for information. Basic terms and features of components are provided in Figure 1.

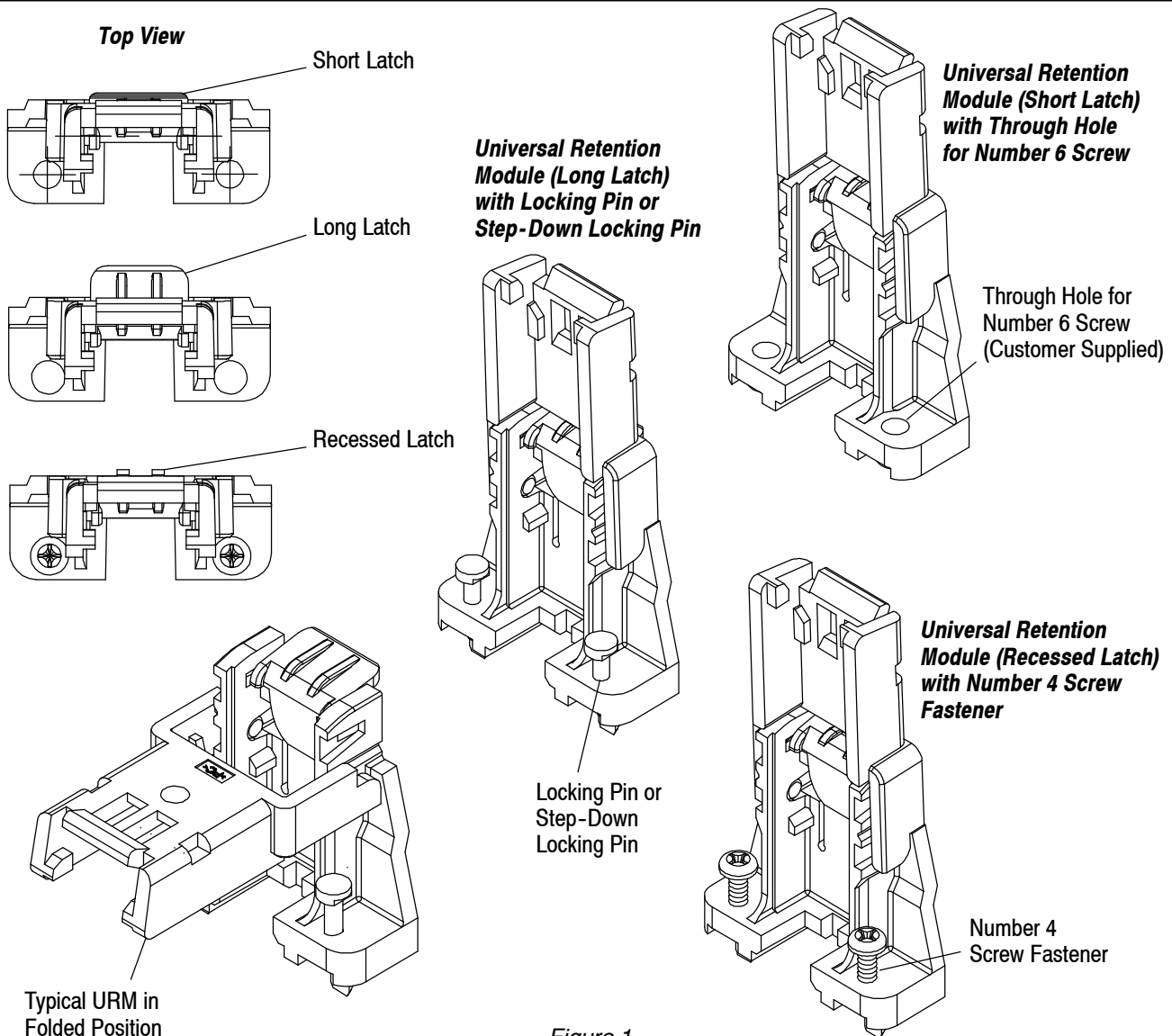

Figure 1

2. REFERENCE MATERIAL

2.1. Revision Summary

- Updated document to corporate requirements
- New logo and format

2.2. Customer Assistance

Reference Part Number 145380 and Product Code 2157 are representative numbers of Universal Retention Modules. Use of these numbers will identify the product line and expedite your inquiries through a service network established to help you obtain product information. Such information can be obtained through a local Tyco Electronics Representative or, after purchase, by calling the Tooling Assistance Center or the Product Information Center number at the bottom of page 1.

2.3. Drawings

Customer Drawings for retention modules are available from the service network. The information contained in Customer Drawings takes priority if there is a conflict with this specification or with any technical documentation supplied by Tyco Electronics.

2.4. Specifications

Product Specification 108-1826 provides product performance requirements and test information.

3. REQUIREMENTS

3.1. Storage

A. Ultraviolet Light

Prolonged exposure to ultraviolet light may deteriorate the chemical composition used in the retention module material.

B. Shelf Life

To prevent damage to the retention modules, they should remain in the shipping containers until ready for installation. Also, to prevent possible storage contamination, the modules should be used on a first in, first out basis.

3.2. Keep- Out Zones

Figure 2 provides keep-out zone dimensions for application of Universal Retention Modules. These dimensions should be observed if proper insertion and removal of the connector is to be maintained without obstruction.

NOTE

Careful consideration to the tolerances must be observed when more than one pair of modules is to be used on pc boards. See Figure 2. Tolerance build-up on the pc board in conjunction with the tolerances associated with placing the connectors could cause a stress load on the solder joints of the connectors which could affect their reliability.

**Keepout Zone for Universal Retention Modules with Short, Long, and Recessed Latch
(All Other System Components Must Be Located Outside of the Areas Occupied by the Module)**

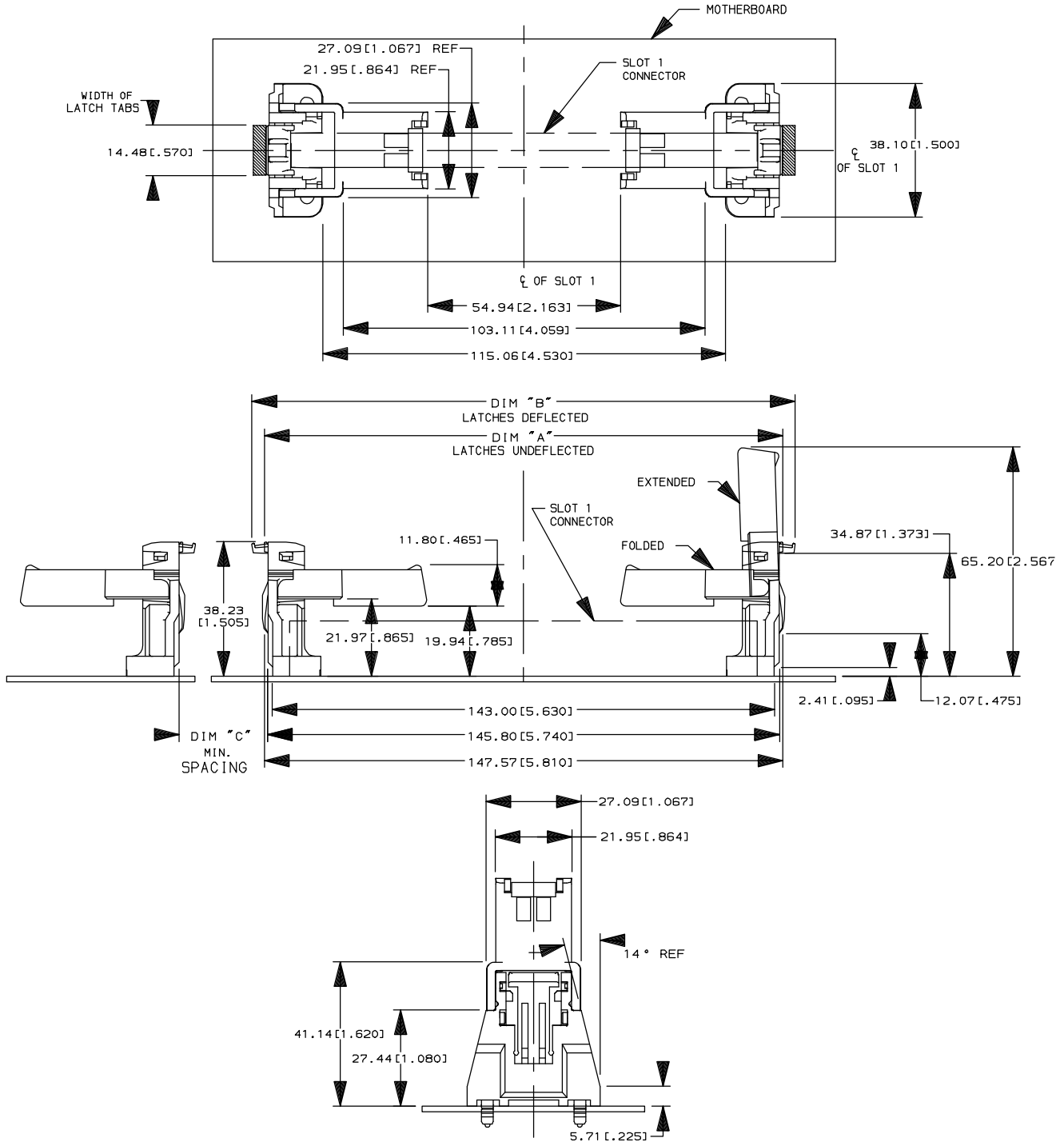

MODULE VERSION	DIMENSION		
	A	B	C
Short Latch	147.83 [5.820]	155.19 [6.110]	10.16 [1.400]
Long Latch	154.94 [6.100]	162.31 [6.390]	17.27 [1.680]
Recessed Latch	143.76 [5.660]	151.13 [5.950]	6.35 [1.250]

Figure 2

3.3. PC Board Requirements

A. Material and Thickness

The pc board material shall be glass epoxy (FR-4 or G-10). The thickness of the pc board should be 1.60 ±0.15 mm [.063 ±.006 in.] thick to ensure retention and stability for which the modules are designed. Consult Tyco Electronics for suitability of other materials.

B. PC Board Layout

Recommended pc board pattern for module installation is provided in Figure 3.



Figure 3 represents a **typical** pc board layout for this product. For dimensions and hold pattern layout for specific product, obtain the appropriate customer drawing through your Tyco Electronics Representative or refer to the telephone numbers at the bottom of page 1.

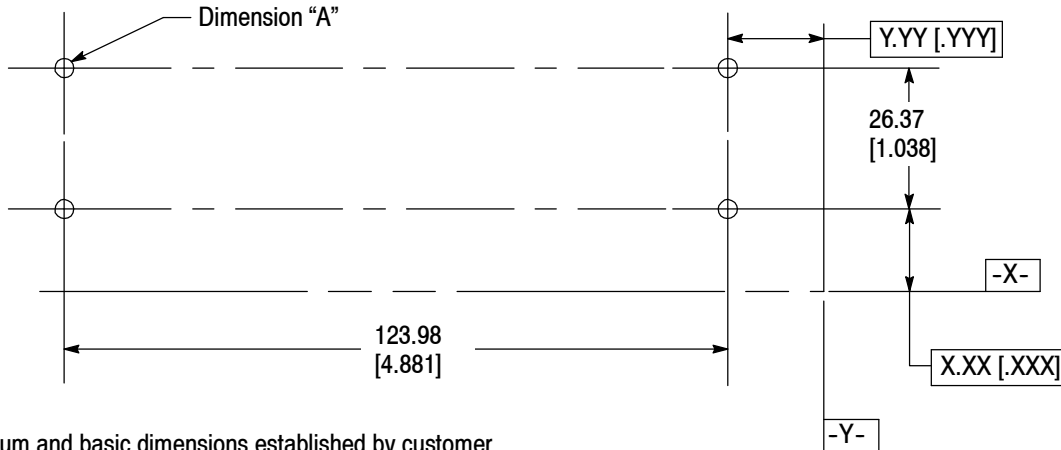

NOTE: Datum and basic dimensions established by customer.

MOUNTING TYPE	DIMENSION A
THROUGH HOLE (ESTABLISHED BY CUSTOMER) FOR NUMBER 6 SCREWS	$\varnothing X.XX [.XXX]$ 4 PLC
LOCKING PIN	$\varnothing 4.04 +0.05/-0.02 [.159 +.002/-0.001]$ 4 PLC
STEP-DOWN LOCKING PIN	$\varnothing 3.56 +0.05/-0.02 [.140 +.002/-0.001]$ 4 PLC
NUMBER 4 SCREW	$\varnothing 4.04 +0.05/-0.02 [.159 +.002/-0.001]$ or $\varnothing 3.56 +0.05/-0.02 [.140 +.002/-0.001]$ 4 PLC

Figure 3

3.4. Module Insertion and Seating

The retention module must seat on the pc board to the dimensions shown in Figure 4. The retention module must be located with the pc board layout holes and fastened securely. If locking pins are used, the straight locking pin requires an insertion force of 66 N [12 lbs], and the stepped locking pin requires an insertion force at 102 N [23 lbs]. If a number 4 screw is used, it requires a torque of .339 N•m [3 in.-lb]. Testing has shown that the insertion forces varies depending on circuit board thickness and board hole diameter.

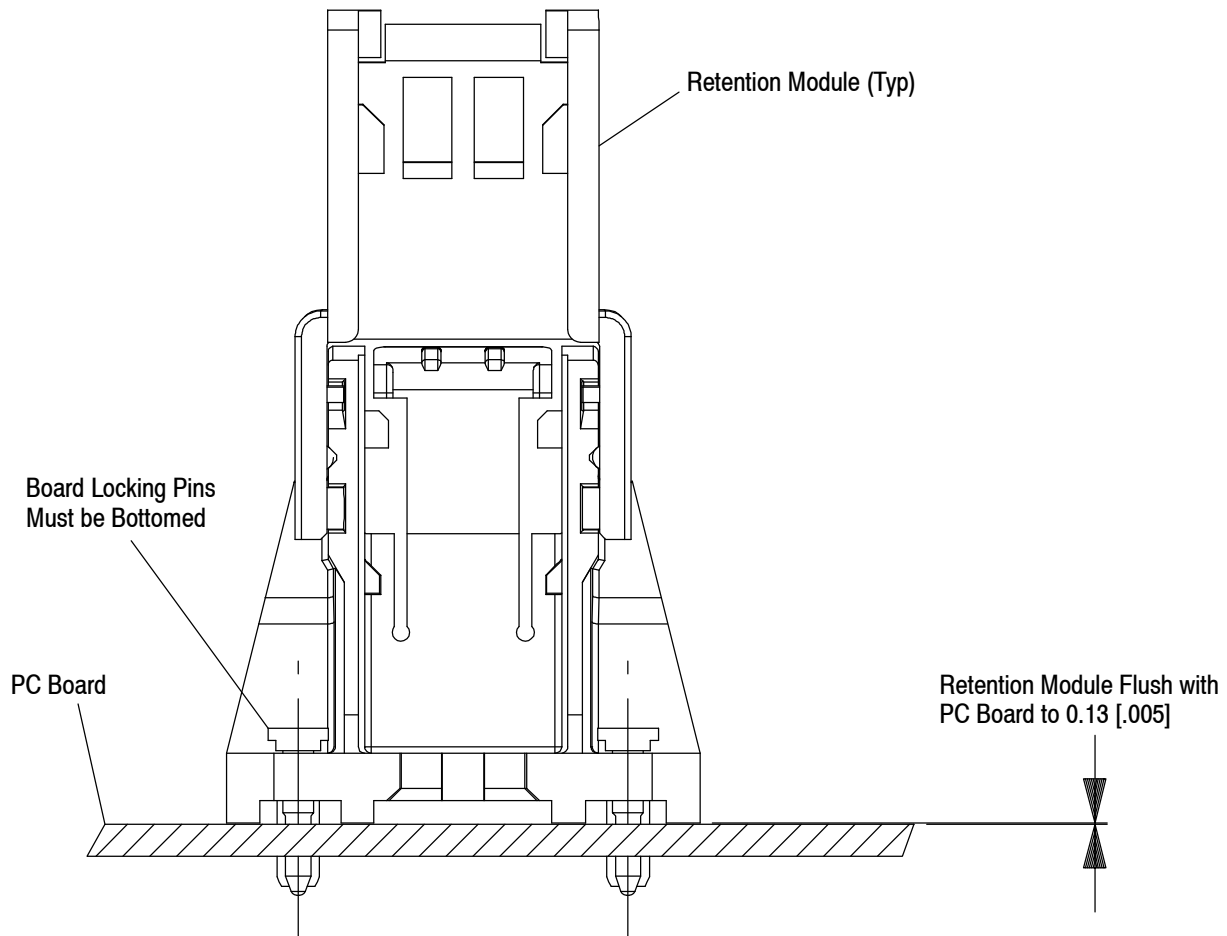

Figure 4

3.5. Repair/Replacement

Retention Modules must be replaced if damaged or broken. Remove retention modules before the connector. Unseat the locking pins from top, or unscrew the self-tapping screws or machine screws; then remove modules from the pc board.

4. QUALIFICATIONS

Universal Retention Modules for 1 mm Standard Edge Connectors are not required to be agency approved.

5. TOOLING

No specific tooling is required for the insertion or application of Retention Modules except a standard number 1 cross-recessed screwdriver for self-tapping number 4 screws or a number 2 cross-recessed screwdriver for number 6 machine screws.

6. VISUAL AID

Figure 5 shows a typical application of Universal Retention Modules for 1 mm Standard Edge Connectors. This illustration should be used by production personnel to ensure a correctly applied product. Applications which DO NOT appear correct should be inspected using the information in the preceding pages of this specification and in the instructional material shipped with the product or tooling.

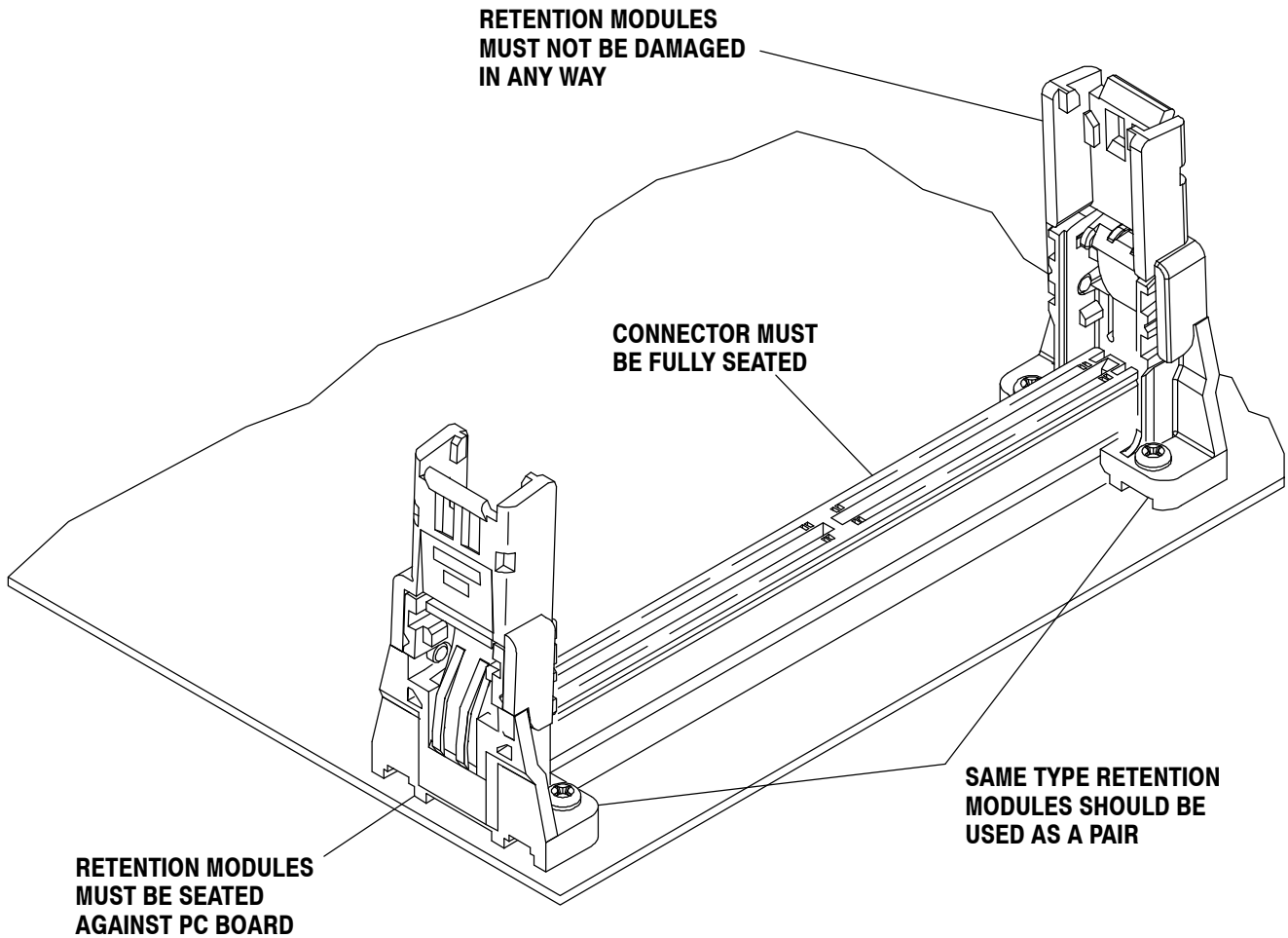

FIGURE 5. VISUAL AID