

**Bus Bar Connection System**
*Restricted to Emerson Network Power*
**NOTE**

All numerical values are in metric units [with U.S. customary units in brackets]. Dimensions are in millimeters. Unless otherwise specified, dimensions have a tolerance of  $\pm 0.13$  and angles have a tolerance of  $\pm 2^\circ$ . Figures and illustrations are for identification only and are not drawn to scale.

**1. INTRODUCTION**

This specification covers the requirements for application of the Bus Bar Connection System. This system is designed to provide a configurable power distribution for DC powered equipment inside a stationary rack.

The Bus Bar Connection System consists of connection components as shown in Figure 1. Main component is the bus bar: an extruded profile holding two solid copper conductor bars. Power is supplied to the conductor bars with 50 mm<sup>2</sup> or 95 mm<sup>2</sup> wires and RAPID LOCK\* Right-Angle Sockets or Ring Tongue terminals. A Circuit Breaker Connector (CBC) can be mated onto the bus bar on any location along the length of the bus bar. The CBC accepts industry standard flange mount circuit breakers with tab terminals. A Positive Lock output cable assembly connects the CBC to the power supply equipment.

When corresponding with Tyco Electronics Personnel, use the terminology provided on this specification to help facilitate your inquiry for information. Basic terms and features of components are provided in Figure 1.

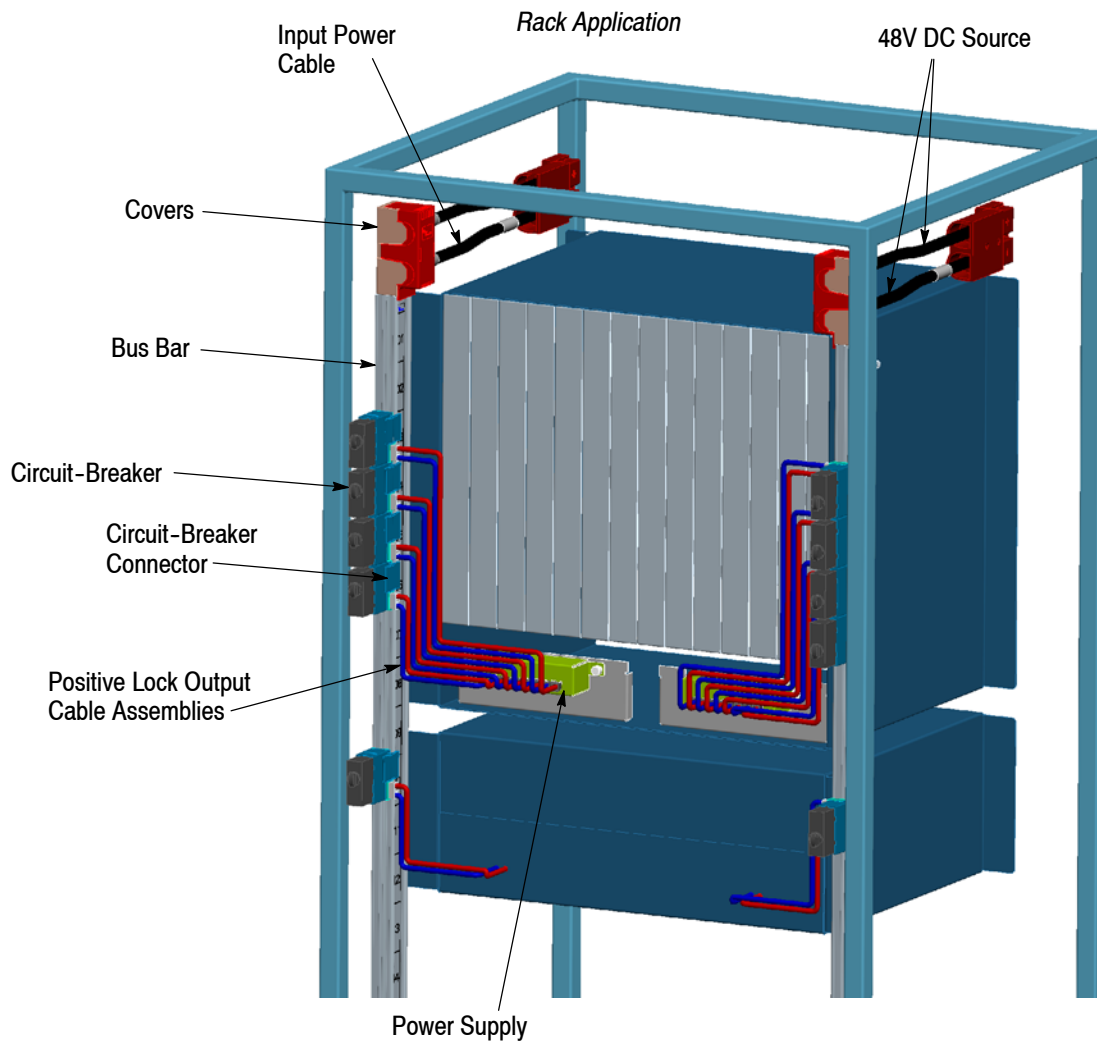

Figure 1

## 2. REFERENCE MATERIAL

### 2.1. Revision Summary

- Updated document to corporate requirements
- Changed artwork in Figures 1 and 7
- Updated text in Section 1, INTRODUCTION

### 2.2. Customer Assistance

Reference Base Part Numbers 1551791, 1551683, and Product Code D040 are representative numbers of the Bus Bar Connection System. Use of these numbers will identify the product line and expedite your inquiries through a service network established to help you obtain product and tooling information. Such information can be obtained through a Tyco Electronics Representative or, after purchase, by calling the Product Information Center at the number at the bottom of page 1.

### 2.3. Drawings

Customer Drawings for product part numbers are available from the service network. If there is a conflict between the information contained in the Customer Drawings and this specification or with any other technical documentation supplied, call the Product Information Center at the number at the bottom of this page.

### 2.4. Specifications

Product Specification 108-19299 provides product performance and test information.

## 3. REQUIREMENTS

### 3.1. Storage

#### A. Ultraviolet Light

Prolonged exposure to ultraviolet light may deteriorate the chemical composition used in the contacts.

#### B. Shelf Life

The connectors and contacts should remain in the shipping containers until ready for use to prevent deformation to the contacts and/or damage to the housings. The contacts should be used on a first in, first out basis to avoid storage contamination that could adversely affect signal transmissions.

#### C. Chemical Exposure

Do not store contacts near any chemicals listed below, as they may cause stress corrosion cracking in the contacts.

Alkalies	Ammonia	Citrates	Phosphates	Citrates	Sulfur Compounds
Amines	Carbonates	Nitrites	Sulfur	Nitrites	Tartrates

### 3.2. Characteristics

The total maximum current load is 300A for the RAPID LOCK and ring tongue connections. This means that with a circuit-breaker of 25A (max) in each CBC, a maximum of 12 circuit-breakers can be added to the system in order to avoid overload. The CBC connection can handle 30A (max - absolute limit), but then only ten CBCs can be used at the same time. If 15A circuit-breakers are used, then 20 CBCs can be added to the system.

The connection between CBC and power unit is made with a cable assembly with positive lock connectors. The main advantage of positive lock is that if the cable is pulled, the connector cannot be disconnected. The user must pull on the housing to disconnect the cable.

### 3.3. Mating Parts

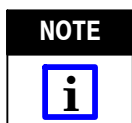

*Bus bar assembly 1551791 consists of Bus Bar 1551683 and DC Power input cable assembly 2142119. Bus Bar 1857561 and 1551683 are designed as a connector pair with CBC 1551796-1. CBC 1551796-1 and special keyed positive lock housing 1969364-1 of cable assembly 1820539-2 are designed as a connector pair. No other connectors should be mated unless approved by Tyco Electronics Engineering.*

**3.4. Bus Bar Mounting** (Figure 2)

The bus bar should be mounted accordingly:

1. The bus bar is mounted in the cabinet with the M5 thread ends of the fixed slide nuts in the rear.
2. The torque to be applied to the M5 mounting nuts is 1.5 Nm [13.28 lbf-in.] max.
3. The mounting surface of the bus bar should be flat and straight, and provide sufficient support.
4. All M5 nuts and washers must be mounted.
5. The base cover is to be mounted before attaching the RAPID LOCK (Figure 2A) or ring tongue connectors (Figure 2B).
6. Base cover can be slid on from the top in -Z direction or snapped on in +Y direction (see Figure 2).
7. To facilitate installation, the cover can be installed before mounting of the bus bar into the cabinet.
8. After snapping on the base cover, the RAPID LOCK (Figure 2A) or ring tongue (Figure 2B) connectors can be mated.
9. The top cover can be installed in a -Y direction.
10. Both latches of the top cover should be fully engaged.
11. Covers can be used in four different cable exit configurations: left-front, right-front, left-rear, right-rear (see Figure 4).

2A (Bus Bar Mounting - RAPID LOCK Connectors)

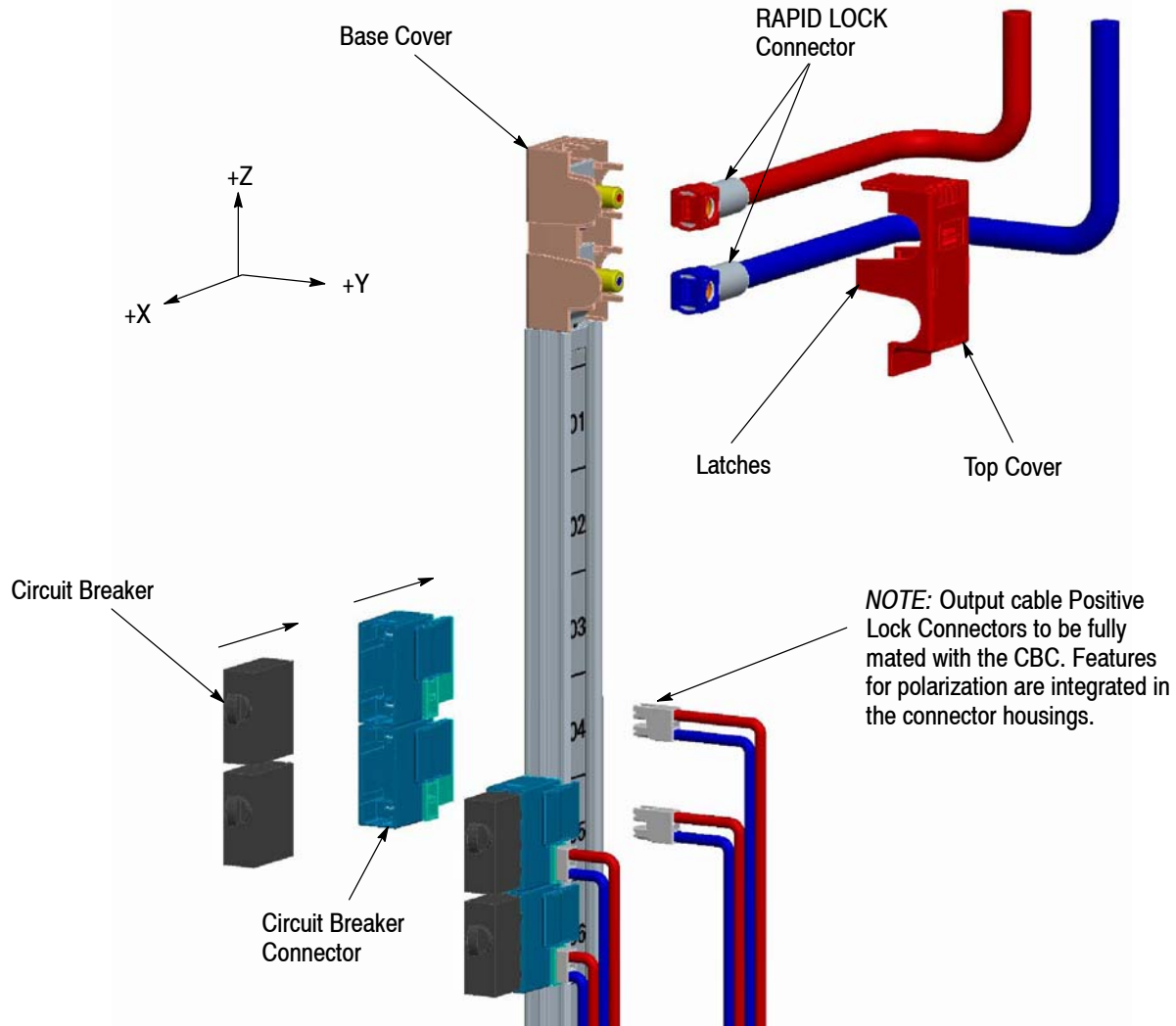

Figure 2 (cont'd)

2B (Bus Bar Mounting - Ring Tongue Connectors)

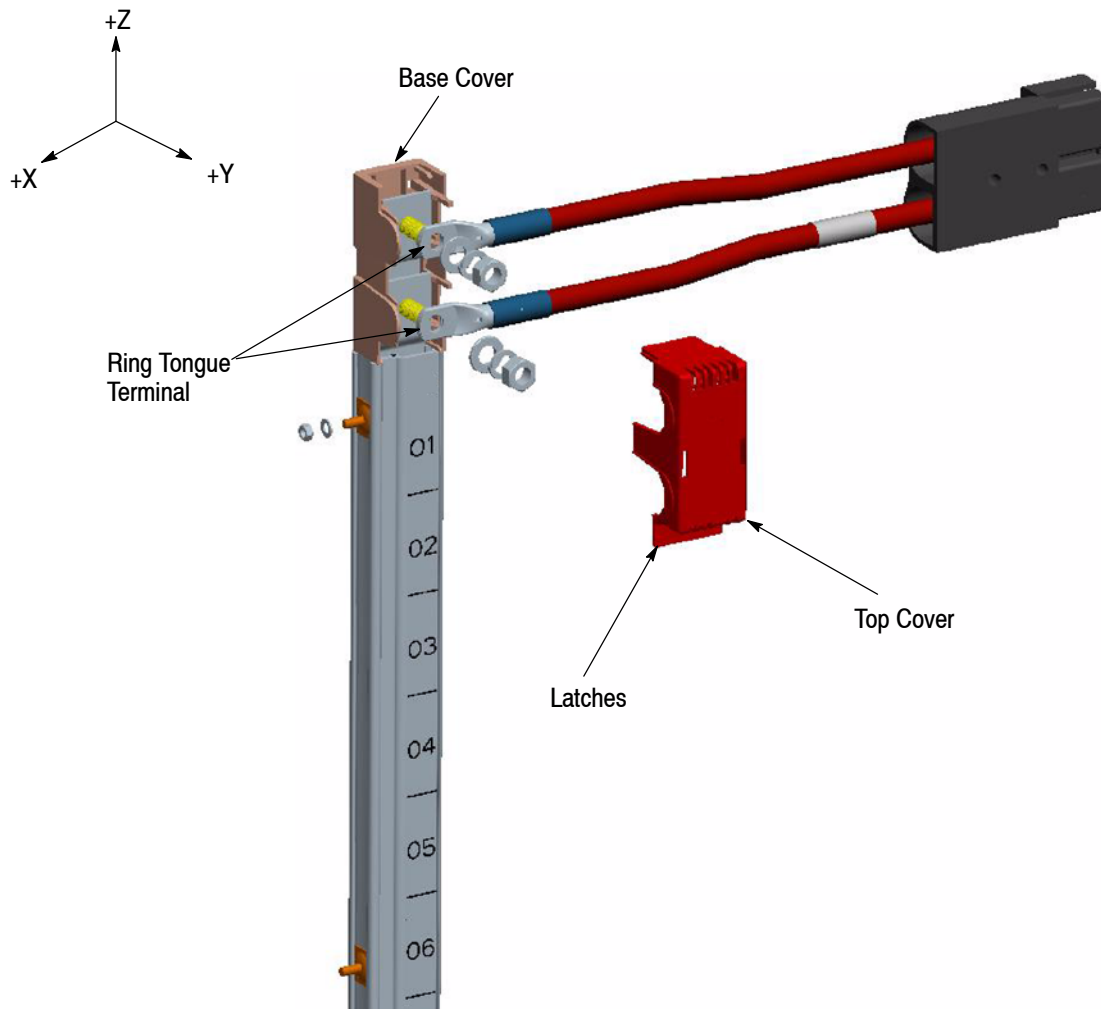

Figure 2 (end)

**3.5. RAPID LOCK and Ring Tongue Connector Mating**

**A. RAPID LOCK Connectors** (Figure 3)

Mating of the RAPID LOCK connector shall be in -Y direction as shown in Figure 2A. The RAPID LOCK connector is to be pushed fully down on the 12 mm pin. The pin should extend approximately 2.0 mm above the surface as shown in Figure 3.

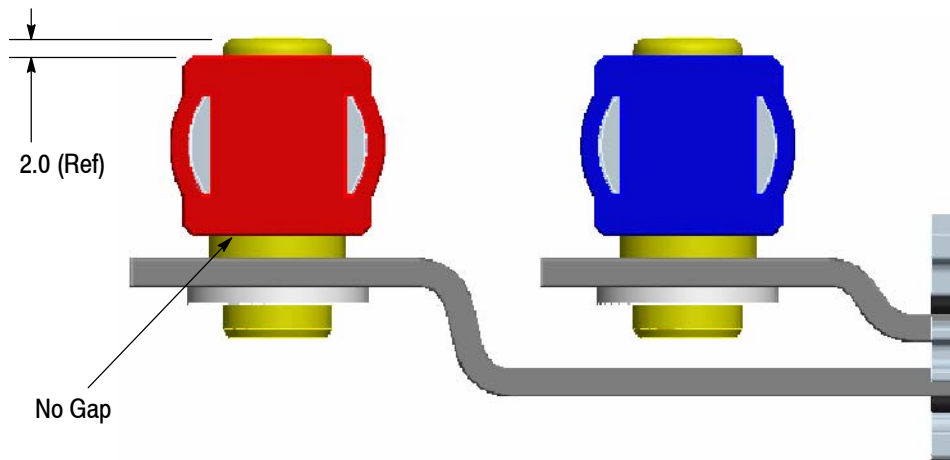

Figure 3

High-stranded cable is advised, in order to prevent forces due to bending of the cable onto the RAPID LOCK connection. The covers provide a secondary securing of the RAPID LOCK connectors, and guidance for front or rear exit.



*Great care should be taken not to damage the connector when using tools to unlock the RAPID LOCK connector. Do not unmate by applying an asymmetrical load, causing jamming.*

**B. Ring Tongue Mating (Factory Connected) (Figure 4)**

Mating of the ring tongue connector shall be as shown in Figure 2B. A washer, spring-washer and M10 nut is added and torqued to a maximum of 10.4 N•m [92.05 lbf-in.].

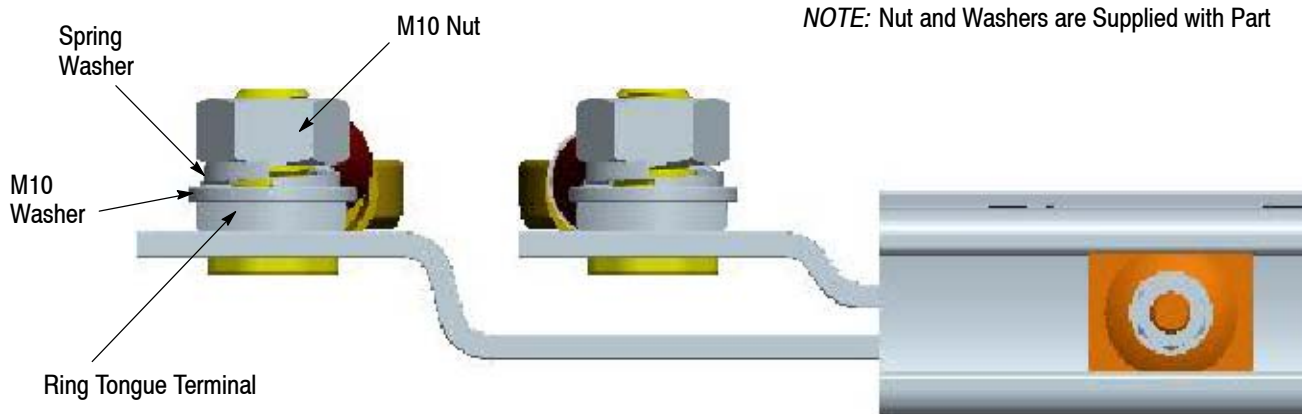

Figure 4

High-stranded cable is advised, in order to prevent forces due to bending of the cable onto the ring tongue connection. The covers provide a secondary securing of the ring tongue connectors, and guidance for front or rear exit.

**3.6. Cover Configurations**

Covers can be installed in four different cable exit configurations: left-front, right-front, left-rear, right-rear (see Figure 5).

*Ring Tongue Connectors Bus Bar Assembly  
(Mounting Hardware Supplied)*

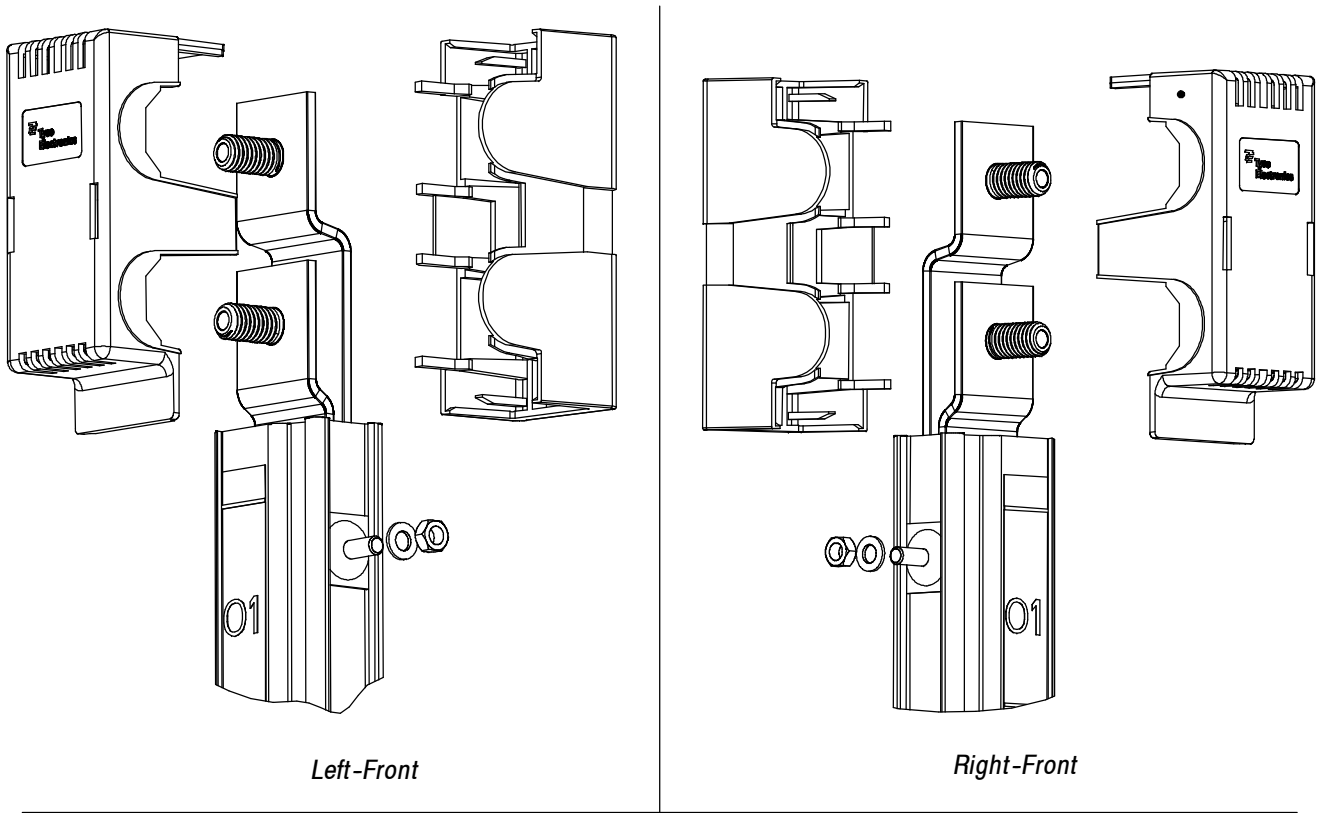

*RAPID LOCK Connectors Bus Bar Assembly  
(Mounting Hardware Supplied)*

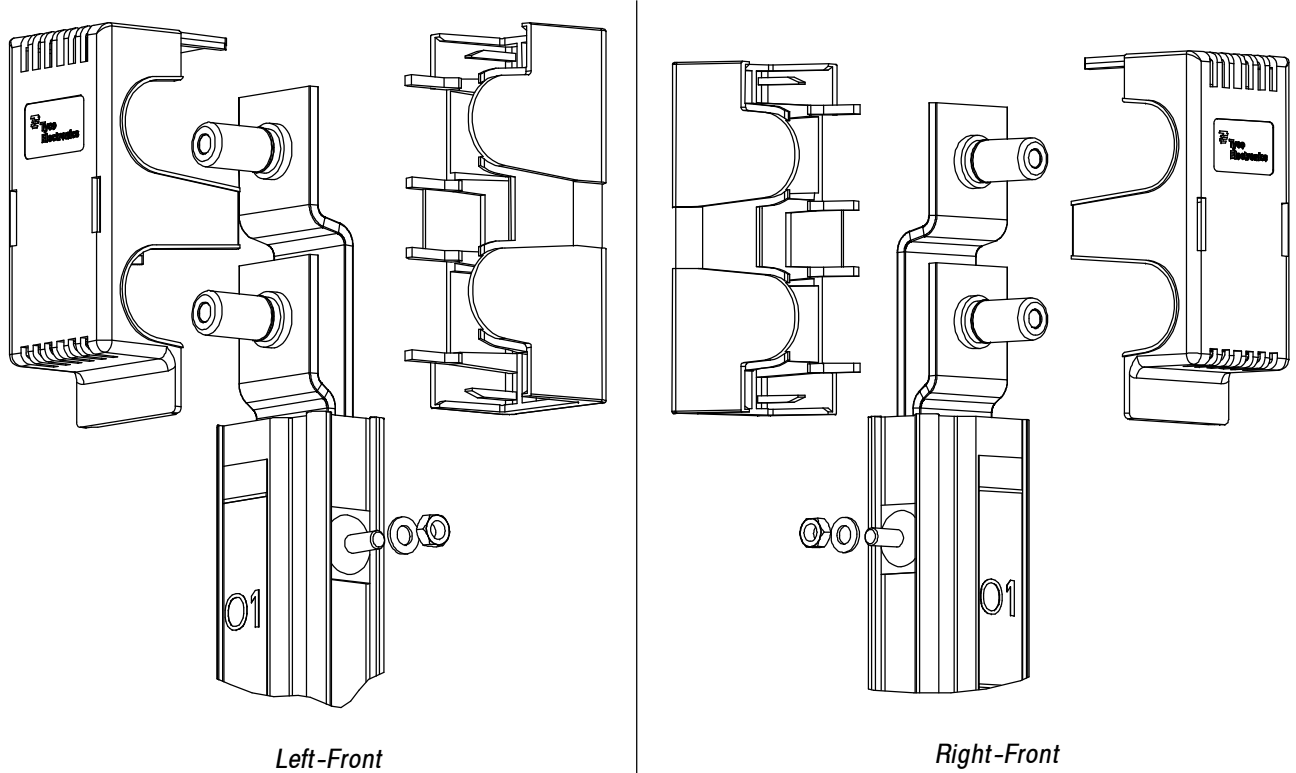
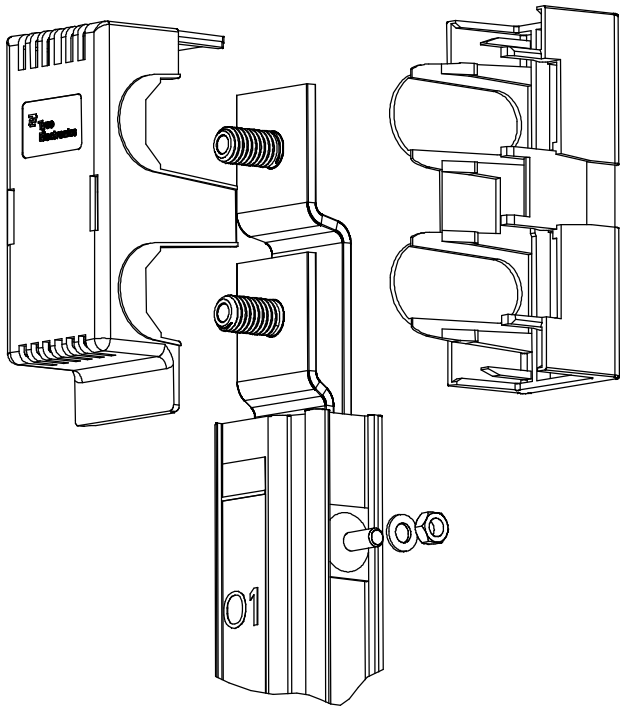
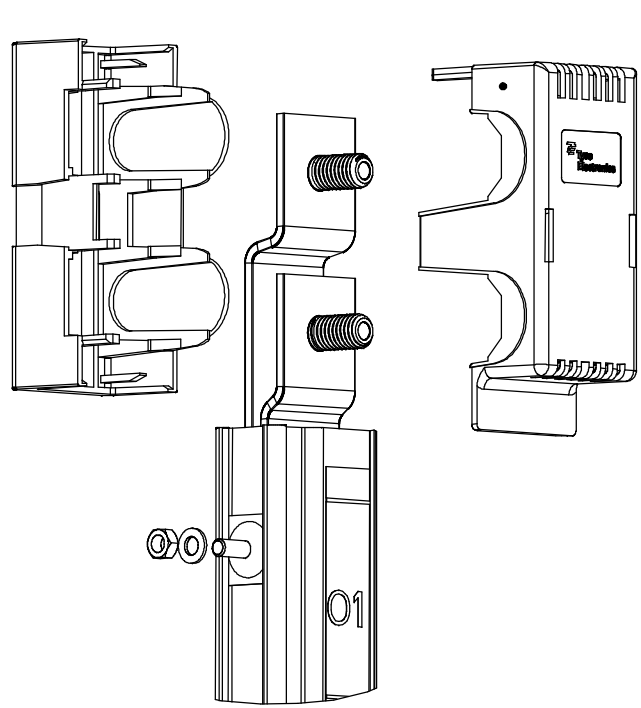

Figure 5 (cont'd)

*Ring Tongue Connectors Bus Bar Assembly  
(Mounting Hardware Supplied)*



*Left-Rear*



*Right-Rear*

*RAPID LOCK Connectors Bus Bar Assembly  
(Mounting Hardware Supplied)*

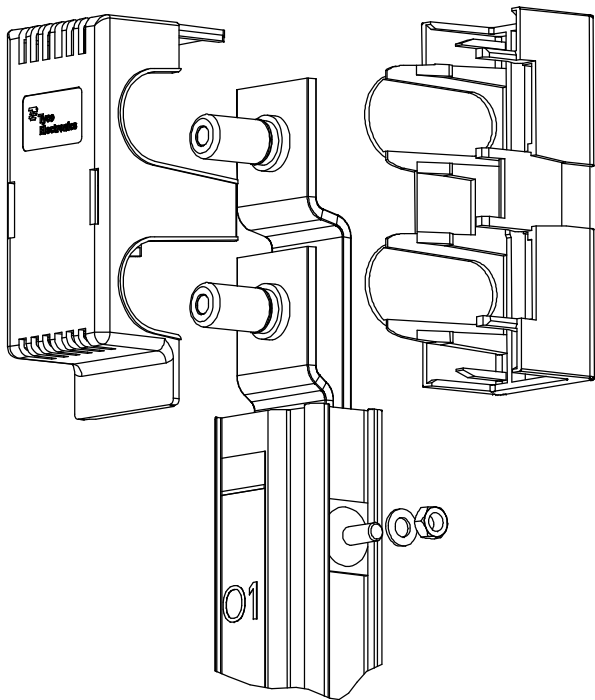

*Left-Rear*

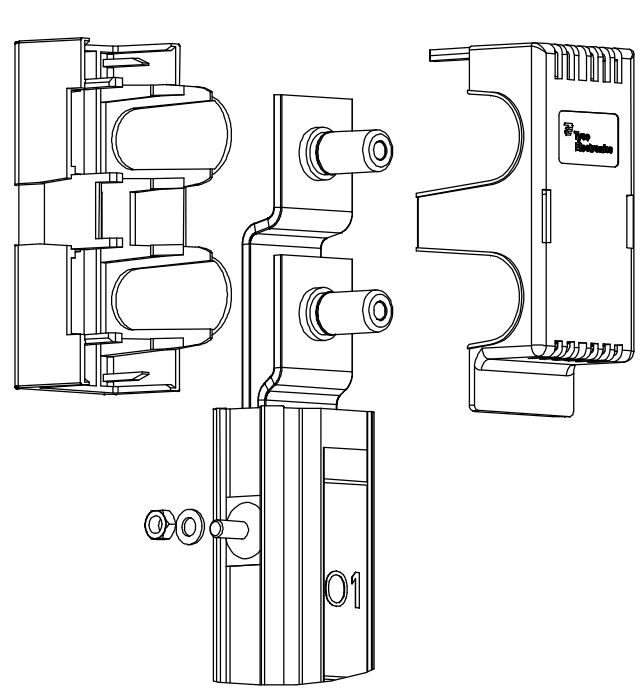

*Right-Rear*

*Figure 5 (cont'd)*

Right Front Entry

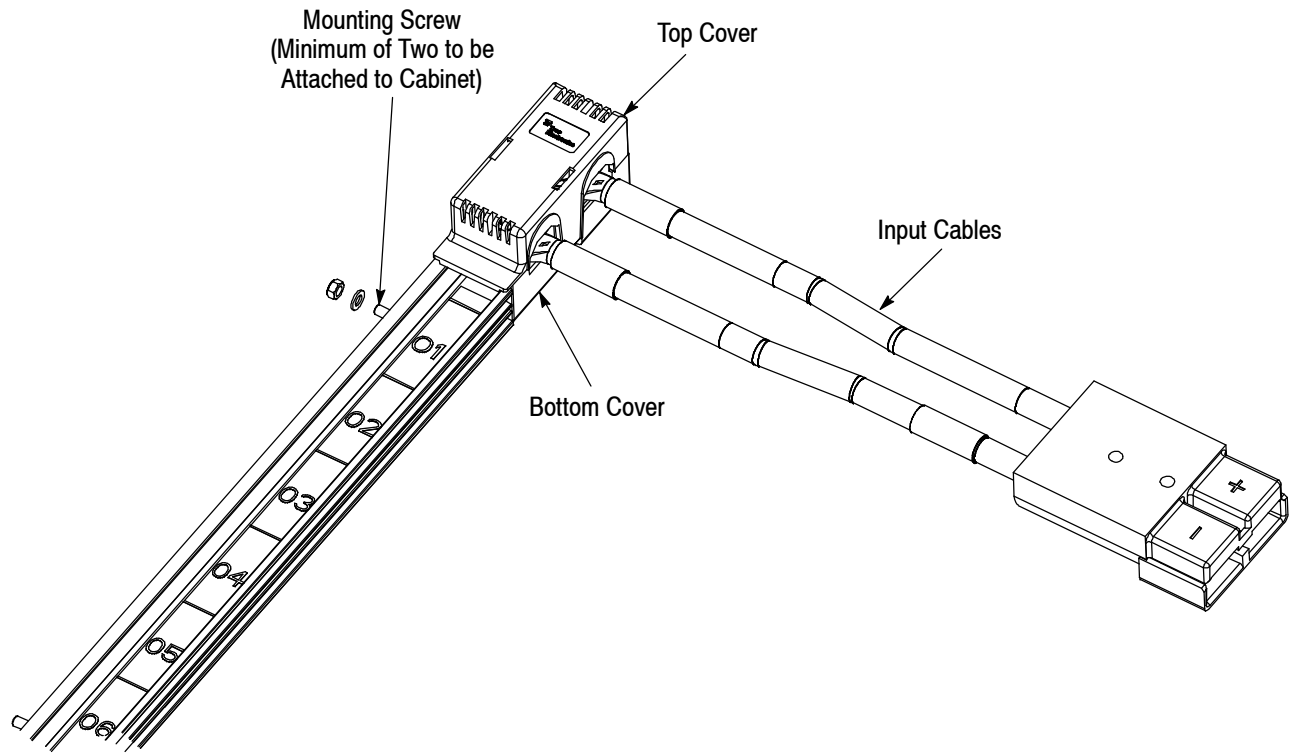

Left Front Entry

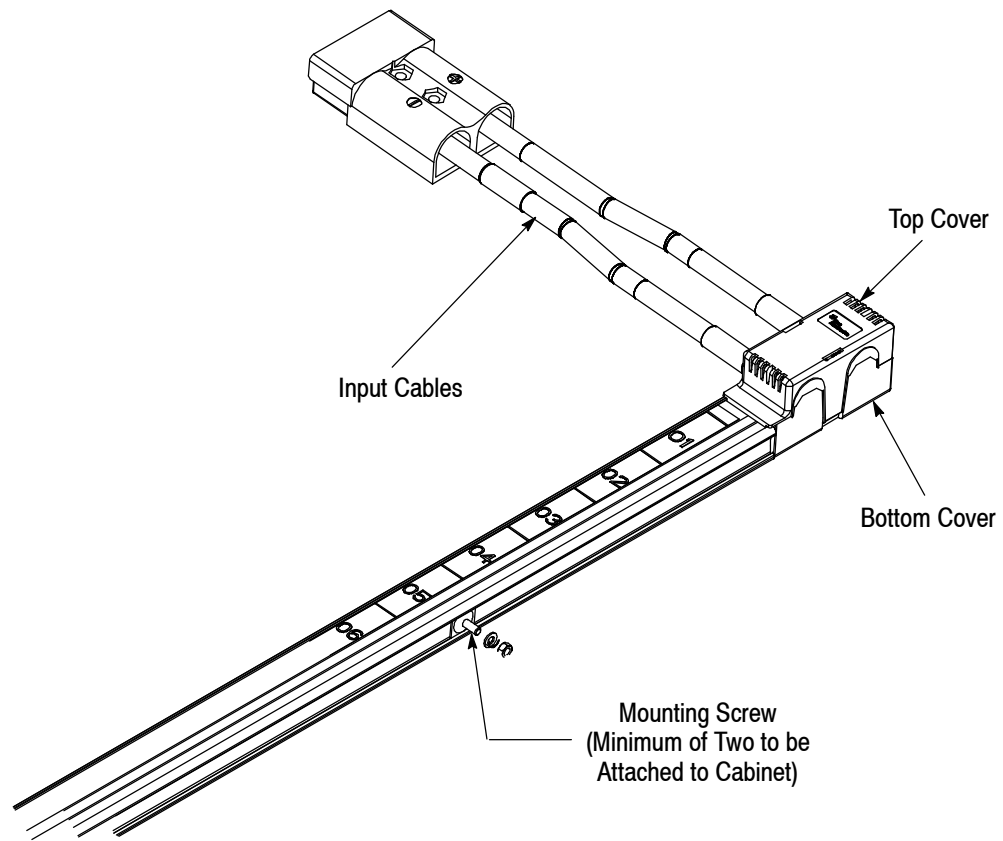

Figure 5 (end)



### 3.7. CBC Mating and Unmating

#### A. Mating

Mating of CBC to the bus bar shall be in -X direction as shown in Figure 2. Correct CBC orientation is when the latch points towards the sticker side of the bus bar (latch side). The latch is to be squeezed for easier mating. The CBC is fully mated when the CBC bottoms on the top surface of the bus bar, and the latch is fully engaged, as shown in figure 6.

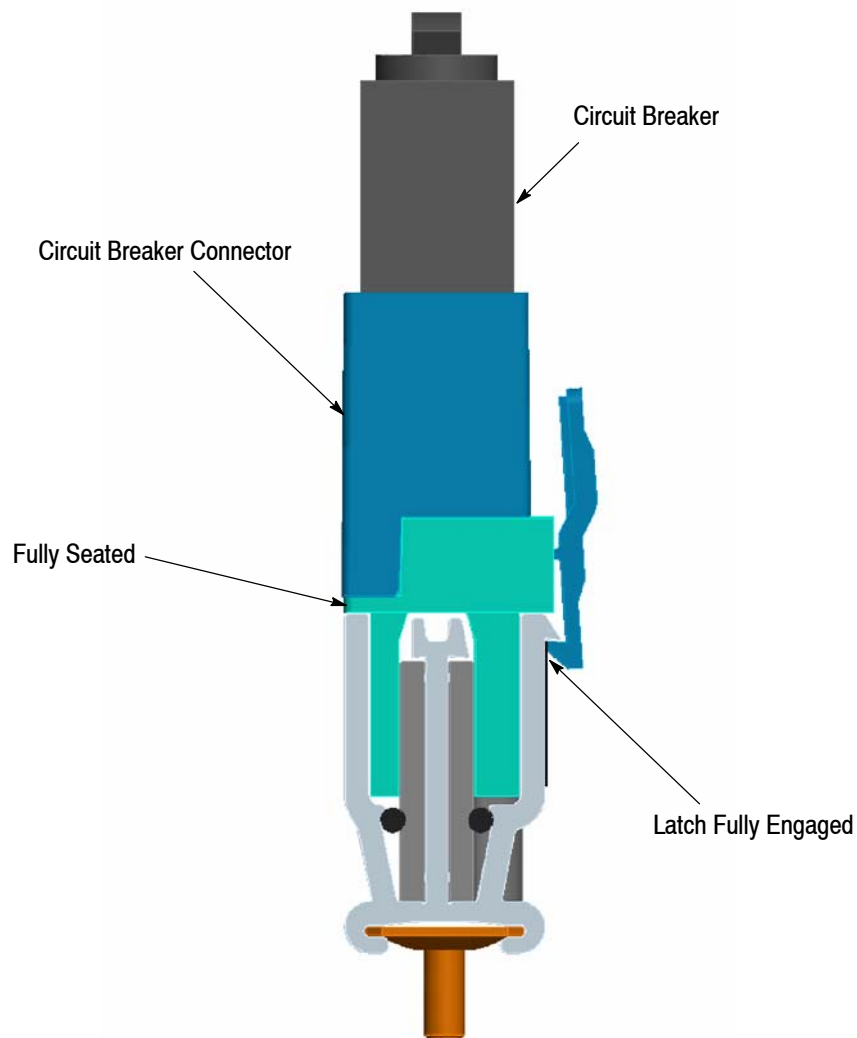

Figure 6

**NOTE**

The circuit breaker connector accepts the following Tyco Electronics Circuit Breakers: 8-1393252-5 (25A); 8-1393252-4 (20A); 8-1393252-2 (15A); and 8-1393252-1 (10A). No other circuit breakers should be mated unless approved by Tyco Electronics Engineering.

**CAUTION**

The bus bar system is polarized to prevent mismating, but when using excessive force, and/or wiggling the CBC connector, it is possible to mate the CBC the wrong way.

## B. Unmating

**DANGER**

*The breaker should be switched off prior to pulling the breaker from the CBC to prevent injury.*



To unmate the CBC, depress the latch fully and pull straight in +X direction. The latches are designed to hold the CBC onto the bus bar when pulling the CBC or cable, but will release when pulled hard in unmating direction (+X).

### 3.8. Breaker Mating

Mating of the breaker into the CBC shall be in -X direction as shown in Figure 2. Breaker is fully seated when it bottoms in the CBC.

### 3.9. Mechanical Stability

The construction in the application shall provide mechanical stability in order to comply with the requirements specified in Paragraphs 3.4 and 3.5. This will avoid unacceptable force loads on the connectors as well as on cable assemblies. Arrangement of the cable assemblies must not put permanent forces on the CBC.

### 3.10. Abuse and Misuse

**CAUTION**

*The construction in the application shall ensure that abuse and misuse will not lead to damage on the connectors. The positive lock cable assemblies are to be unmated by pulling the housing. Due to the positive lock principle, the connectors will not unmate when pulling the cable itself. Do not try to unmate by pulling the cable.*

**CAUTION**

*After final installation in a cabinet, the connectors shall not be deformed and their plating shall not be scratched by tools, collisions, or any other cause during the assembly process. Damaged product must be replaced.*

## 4. QUALIFICATIONS

RAPID LOCK terminals are Recognized to Underwriters Laboratories Inc. (UL) and CSA International by UL in File E28476. Bus bars are Recognized in UL File 508. Ring tongue terminal 710025-5 is currently being evaluated by UL.

## 5. TOOLING

No specialized tooling is required for the assembly of the Bus Bar Connector System.

**6. VISUAL AID**

Figure 7 shows a typical application of the Bus Bar Connection System. This illustration should be used by production personnel to ensure a correctly applied product. Applications which DO NOT appear correct should be inspected using the information in the preceding pages of this specification and in the instructional material shipped with the product or tooling.

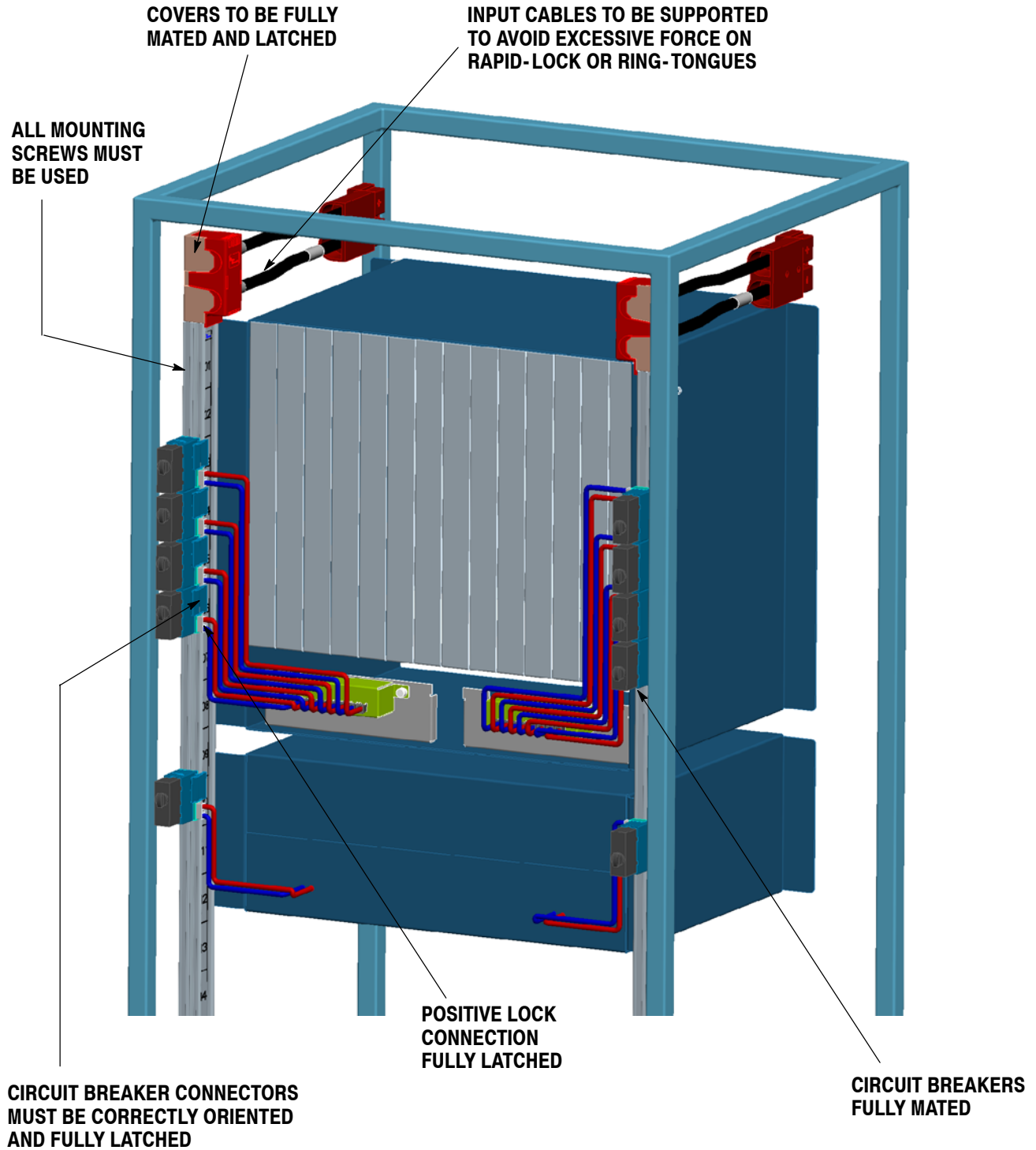

**FIGURE 7. VISUAL AID**