



**Low Profile Power 2P Connector**

**1. SCOPE ..... 2**

1.1 CONTENT..... 2

**2. APPLICABLE DOCUMENTS ..... 2**

2.1 Tyco Electronics Specification ..... 2

2.2 Industry Document ..... 2

2.3 Reference Document .....2

**3. REQUIREMENTS ..... 2**

3.1 DESIGN AND CONSTRUCTION ..... 2

3.2 MATERIALS ..... 2

3.3 RATINGS..... 3

3.4 PERFORMANCE REQUIREMENTS AND TEST DESCRIPTION..... 3

3.5 TEST REQUIREMENTS AND PROCEDURES SUMMARY..... 3~5

3.6 PRODUCT QUALIFICATION TEST SEQUENCE ..... 6~7

**4. QUALITY ASSURANCE PROVISIONS..... 8**

4.1 TEST CONDITIONS..... 8

4.2 TEST .....8

4.2.1 Test Specimens.....8

**5. CURRENT-TEMPERATURE DERATING.....9**



## 1. Scope

### 1.1 Content

This specification covers the requirements for product performance, test methods and quality assurance provisions of Low Profile Power 2P connector.

### 1.2 Revision Summary

Revisions to this specification include:

- 109-5000 is removed and 109-1 is added.
- Application Spec. is changed from 114-13265 to 114-61072.
- Temperature rating is changed from -25°C to -40°C.
- Condition of Resistance to Cold (3.5.25) is -30°C to -40°C.
- Test items are reorganized.
- GWEPT requirement is added.
- Clarified contact retention force with TPA from 29.4N to 49N Min.
- Clarified durability from 50 to 30 cycles
- Crimp Tensile Strength is removed in test group 18

## 2. Applicable Documents

The following documents form a part of this specification to the extent specified herein. In the event of conflict between the requirements of this specification and the product drawing, the product drawing shall take precedence. In the event of conflict between the requirements of this specification and the referenced documents, this specification shall take precedence.

### 2.1 Tyco Electronics Specifications:

- A. 114-61072 : Application Specification for Low Profile Power 2P Connector

### 2.2 Industry Document :

- A. EIA-364: Electrical Connector/Socket Test Procedures Including Environmental Classifications

### 2.3 Reference Document :

- A. 109-1: General Requirements for Testing
- B. 109-197: Test Specification (AMP Test Specifications vs EIA and IEC Test Methods)

## 3. Requirements

### 3.1 Design and Construction:

Product shall be of the design, construction and physical dimensions specified on the applicable product drawing.

### 3.2 Materials:

- A. Receptacle Contact:
  - I) Pre-Tin Phosphor Bronze Type (Tin PL 1.0 um min.)
- B. Plug Housing: PET/PC Alloy (UL94 V-0), GWT
- C. Header Assembly:
  - I) Header Housing : PA66 Glass Filled (UL94 V-0), GWT

II) Post Contact : Tin Plated Brass

D. TPA : PA66 Glass Filled (UL94 V-0), GWT

### 3.3 Ratings:

A. Voltage Rating: 300 VAC, DC

B. Current Rating: 12A Max

Refer to Fig. 1 for maximum allowable current to be applied.

Wire Size		Maximum Allowable Current			
		AWG#16	AWG#18	AWG#20	AWG#22
Pitch	Pos.	12A	11A	10A	9A
11.0mm	2				

Fig. 1

C. Temperature Rating: -40°C to 105°C

D. Applicable P.C.B

I ) Thickness 1.6mm

II ) Diameter of hole for Tine: 1.65+0.1/-0 mm (Drilled Hole), 1.60+0.1/-0 mm (Punched Hole)

### 3.4 Performance Requirements and Test Descriptions:

The product shall be designed to meet the electrical, mechanical and environmental performance requirements specified in Fig. 2. All tests shall be performed in the room temperature, unless otherwise specified.

### 3.5 Test Requirements and Procedures Summary

Para.	Test Items	Requirements	Procedures
3.5.1	Examination of Product	Meets requirements of product drawing and AMP Specification	EIA-364-18. Visual and dimensional (C of C) inspection per product drawing.
Electrical Requirements			
3.5.2	Termination Resistance (Low Level)	10 mΩ Max. (Initial) 20 mΩ Max. (Final)	EIA-364-23. Subject specimens to 100 mA and 20 mV open circuit voltage. See Figure 4.
3.5.3	Dielectric withstanding Voltage	One minute hold with no breakdown or flashover. Current Leakage: 5 mA Max.	EIA-364-20, Condition I. Hold at 1.5 kV AC at sea level for 1 minute. Test between contacts in adjacent circuits and between housing and all contacts in a mated connector.
3.5.4	Insulation Resistance	1000 MΩ Min. (Initial) 500 MΩ Min. (Final)	EIA-364-21. Apply 500 VDC and hold for 2 minutes. Test between contacts in adjacent circuits

Fig. 2



			and between housing and all contacts in a mated connector.	
3.5.5	Temperature Rising Vs current	30°C Max. under loaded specified current or rating current.	EIA-364-70, Method 1. Stabilize at a single current level until 3 readings at 5 minute intervals are within 1°C. See figure 5	
<b>Mechanical Requirements</b>				
3.5.6	Vibration (Low Frequency)	No Electrical Discontinuity greater than 1 μ sec. shall occur. 20 mΩ Max. (Final)	EIA-364-28, Test Condition VII, Condition Letter D. Subject mated specimens to 3.10 G's rms between 20 to 500 Hz. Fifteen minutes in each of 3 mutually perpendicular planes.	
3.5.7	Physical Shock	No electrical discontinuity greater than 1 μ sec. Shall occur. 20 mΩ Max. (Final)	EIA-364-27, Condition H. Subject mated specimens to 30 G's half-sine shock pulses of 11 milliseconds duration. Three shocks in each direction applied along 3 mutually perpendicular planes, 18 total shocks.	
3.5.8	Connector Mating Force	19.6 N [2.0 Kgf ] Max.	EIA-364-13. Measure force necessary to mate specimens with latches disengaged at a maximum rate of 12.7 mm per minute.	
3.5.9	Connector Unmating Force	3.92 N [ 0.4Kgf ] Min.	EIA-364-13. Measure force necessary to unmate specimens with latches disengaged at a maximum rate of 12.7 mm per minute.	
3.5.10	Connector Locking Strength	2 Pos : 49 N ( 5.0kgf) Min.	EIA-364-98. Measure connector locking strength at a maximum rate of 12.7mm [0.5 in.] per minute.	
3.5.11	Contact Insertion Force	6.9N (700g) Max. per contact	EIA-364-5. Measure force necessary to insert a contact into the housing at a maximum rate of 12.7mm [0.5 in.] per minute.	
3.5.12	Contact Retention Force	With TPA: 49 N (5.0kgf) Min. Without TPA: 29.4N (3.0kgf) Min.	EIA-364-29B Apply axial load at a rate of 4.4 N per second and hold for 6 seconds.	
3.5.13	Contact Mating Force	9.8 N ( 1 .0kgf) Max.	EIA-364-13. Measure force necessary to mate specimens with latches disengaged at a maximum rate of 12.7 mm per minute.	
3.5.14	Contact Unmating Force	Initial: 1.96N ( 0.2Kgf ) Min. After 50 Cycle: 0.98 N (0.1 Kgf) Min.	EIA-364-13. Measure force necessary to unmate specimens with latches disengaged at a maximum rate of 12.7 mm per minute.	
3.5.15	Crimp Tensile Strength	Wire Size	EIA-364-8. Determine crimp tensile at a rate of 25.4 mm per minute.	
		AWG		
		#22		44.5 (4.5)
		#20		62.3(6.3)
		#18		89 (9.1)

Fig. 2 (Cont.)



# Product Specification

108-61208

Rev. A1

		#16	100(10.2)	
3.5.16	Durability (Repeated Mate/ Unmating)	20 mΩ Max. (Final)		No. of Cycles : 30 cycles. IEC 60512-9-1
3.5.17	Post Retention Force	29.4N (3.0 kgf) Min.		Measure post retention force. Operation Speed: 100mm/min
Environmental Requirements				
3.5.18	Solderability	Wet Solder Coverage: 95% Min.		Solder Temperature: 230 ± 5°C Immersion Duration: 3±0.5 seconds Flux: Alpha100 AMP Spec. 109-11
3.5.19	Humidity-Temperature	Insulation resistance (Final) 500 MΩ Min. Termination resistance 20 mΩ Max. (Final) Dielectric withstanding Voltage: No creeping discharge nor flashover shall occur.		EIA-364-31, Method III. Subject specimens to 10 cycles (10 days) between 25° and 65° C at 80 to 100% RH.
3.5.20	Resistance to Soldering Heat	No physical damage shall occur.		Test connector on PCB. Solder Temperature: 260±5°C Immersion Duration: 5±0.5 sec. AMP Spec. 109-5204 Condition A
3.5.21	Thermal Shock	20 mΩ Max. (Final)		EIA-364-32, Test Condition VII. Subject specimens to 10 cycles between – 55° C and 105°C with 30 minute dwells at temperature extremes.
3.5.22	Salt Spray	20 mΩ Max. (Final)		EIA-364-26. Subject mated specimens to 5% salt concentration for 48 hours.
3.5.23	H <sub>2</sub> S	20 mΩ Max. (Final)		Mated connector H <sub>2</sub> S Gas: 3±1ppm, 40±2°C, 96hours
3.5.24	Temperature Life (Heat Aging)	20 mΩ Max. (Final)		EIA-364-17, Method A, Test Condition 4, Test Time Condition C. Subject mated specimens to 105° C for 500 hours.
3.5.25	Resistance to Cold	20 mΩ Max. (Final)		Mated connector -40±3°C, 96 hours AMP Spec. 109-5108-3
3.5.26	Resistance to Ammonia	20 mΩ Max. (Final)		Subject mated specimens to 3% ammonia solution for 7 hours
3.5.27	GWEPT	Flame duration Te-Ti ≤ 2 seconds at 750°C Lighted tissue paper shall not burn.		IEC 60695-2-11 and IEC 60335-1 Tests to be conducted on each of 3 perpendicular sides. Perform a visual check and take picture after the test. Te : Time of Flame Extinguish from test start. Ti :Time of Ignition

Fig.2 (END)



3.6 Product Qualification Test Sequence

Test Examination	Test Group																
	1	2	3	4	5	6	7	8	9	10	11	12	13	14	15	16	17
	Test Sequence (a)																
Examination of Product	1,3	1,4	1,3	1	1,3	1,4	1,7	1,7	1,5	1,4	1,4	1,4	1,4	1,5	1,3	1,3	1,3
Termination Resistance (Low Level)							2,4 .6	2,6	2,4	2,5	2,5	2,5	2,5	2,4			
Dielectric withstanding voltage						3											
Insulation Resistance						2											
Temperature Rising					2												
Vibration(Low Frequency)							5										
Physical Shock							3										
Connector Mating Force								3									
Connector Unmating Force								4									
Connector Locking Strength			2														
Contact Insertion Force				2													
Contact Retention Force						5											
Contact Mating Force		2															
Contact Unmating Force		3															
Crimp Tensile Strength	2																
Durability (Repeated Mate/Unmating)								5									
Post Retention Force																2	
Solderability															2		
Humidity-Temperature																	
Resistance to Soldering Heat																	2
Thermal Shock									3								
Salt Spray										3							
H <sub>2</sub> S Gas												3					
Temperature Life (Heat Aging)											3						
Resistance to Cold												3					
Resistance to Ammonia													3				
GWEPT																	

Fig. 3 (Cont.)

(a) Numbers indicate sequence in which the tests are performed



3.6 Product Qualification Test Sequence

Test Examination	Test Group																
	18	19	20	21	22	23	24	25	26	27	28	29	30	31	32	33	34
	Test Sequence(a)																
Examination of Product	1,4	1,3															
Termination Resistance (Low Level)	2,5																
Dielectric withstanding voltage	7																
Insulation Resistance	6																
Temperature Rising																	
Vibration(Low Frequency)																	
Physical Shock																	
Connector Mating Force																	
Connector Unmating Force																	
Connector Locking Strength																	
Contact Insertion Force																	
Contact Retention Force																	
Contact Mating Force																	
Contact Unmating Force																	
Crimp Tensile Strength																	
Durability (Repeated Mate/Unmating)																	
Post Retention Force																	
Solderability																	
Humidity-Temperature	3																
Resistance to Soldering Heat																	
Thermal Shock																	
Salt Spray																	
H <sub>2</sub> S Gas																	
Temperature Life (Heat Aging)																	
Resistance to Cold																	
Resistance to Ammonia																	
GWEPT		2															

Fig. 3 (End)

(a) Numbers indicate sequence in which the tests are performed

#### 4. Quality Assurance Provisions

##### 4.1 Test Conditions:

Unless Otherwise specified, all the test shall be performed in any combination of the following test conditions.

##### 4.2 Tests:

##### 4.2.1 Test Specimens:

The test specimens to be employed for the tests shall be conforming to the requirements specified in the applicable product drawings. The crimped contacts shall be prepared in accordance with the requirements of applicable application Specification, 114-61072 Economy Power II Contacts on the wires specified.

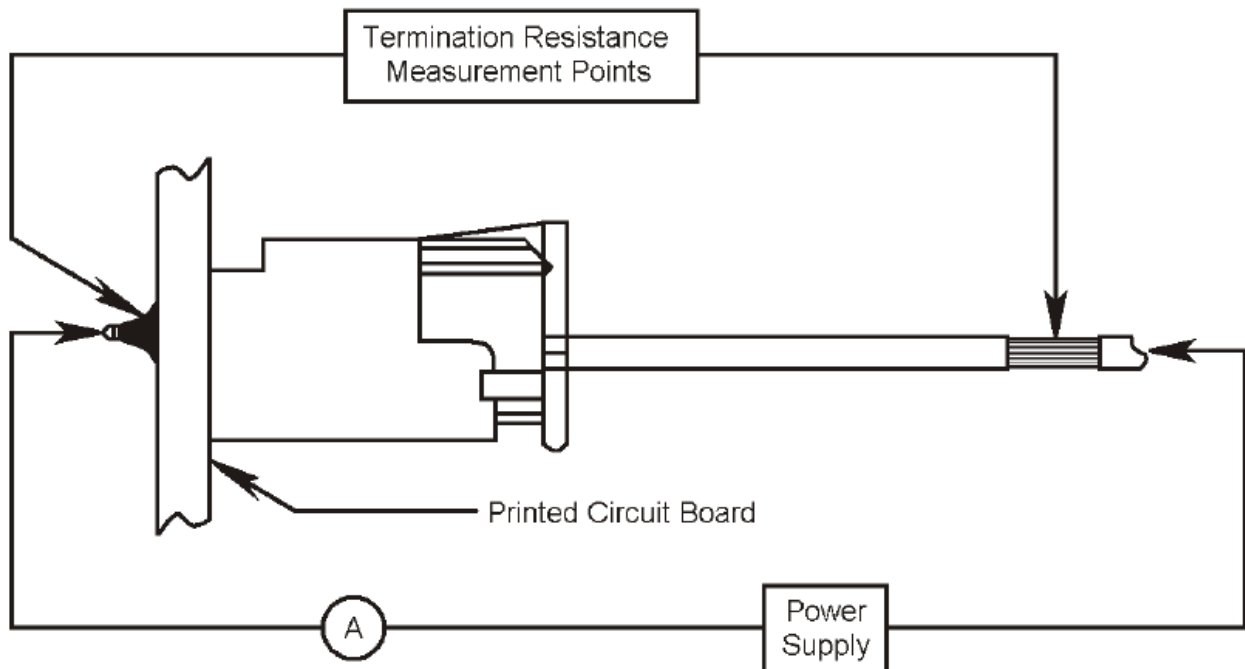

Figure 4



5. Current-Temperature Derating

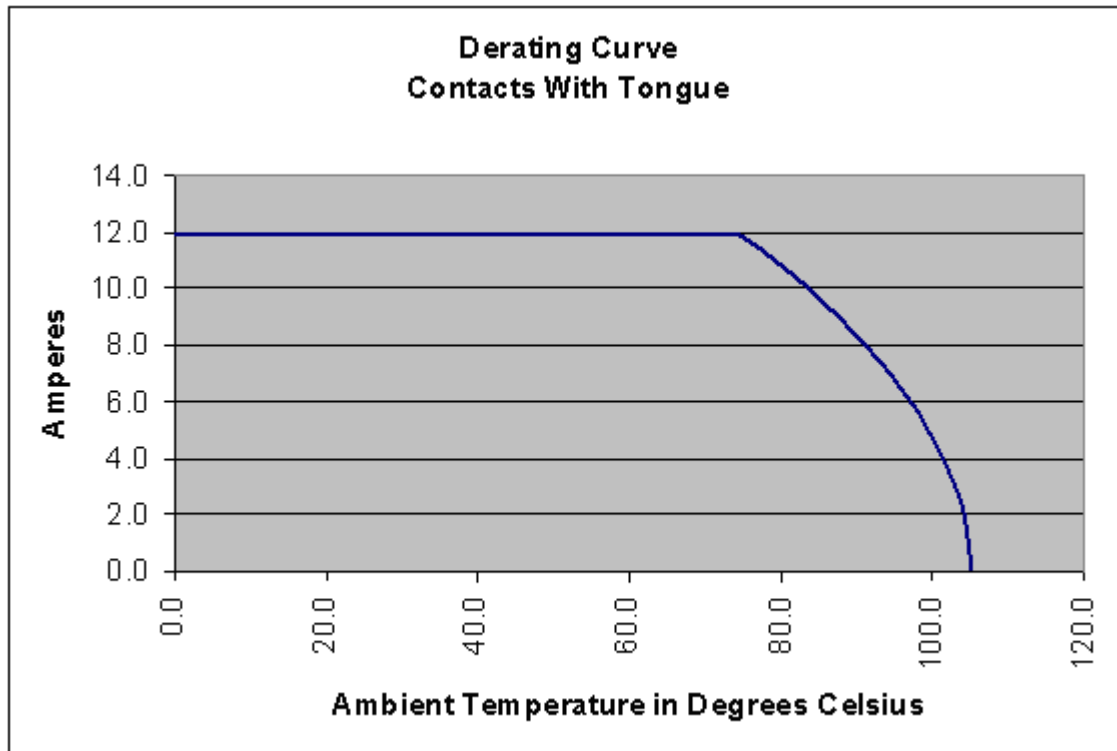

Figure 5