

**1.Scope:**

## 1.1 Contents

This specification covers the requirements for product performance, test methods and quality assurance provisions of FPC SEAT SENSOR CONN.MK-II (SEALED TYPE).

Applicable product description and part numbers are as shown in Appendix 1.

**2.Applicable Documents:**

The following documents from a part of this specification to the extent specified herein. In the event of conflict between the requirements of this specification and the product drawing, the product drawing shall take precedence. In the event of conflict between the requirements of this specification and the referenced documents, this specification shall take precedence.

## 2.1 AMP Specifications:

- A. 109-5000 : Test Specification, General Requirements for Test Methods
- B. 114-5270 : Application Specification, Crimping of FPC Contacts.
- C. 501-5357 : Qualification Test Report

## 2.2 Commercial Standards and Specifications.

- A. JASO D605 : Multi-pole Connector for Automobiles
- B. JASO D7101 : Test Methods for Plastic Molded Parts
- C. JIS C3406 : Low Voltage Wires and Cables for Automobiles
- D. JIS D0203 : Method of Moisture, Rain and Spray Test for Automobile Parts
- E. JIS D0204 : Method of High and Low Temperature Test for Automobile Parts
- F. JIS D1601 : Vibration Testing Method for Automobile Parts

**3.Requirements:**

## 3.1 Design and Construction:

Product shall be of the design, construction and physical dimensions specified on the applicable product drawing.

## 3.2 Material :

- A. Contact :FPC Contact :Copper alloy (Pretinned)
- B. Contact :FPC DIODE Crimp Contact :Copper alloy (Pretinned)
- B. Cover Housing : PBT
- C. Pitch Plate : PBT

## 3.3 Ratings:

- A. Temperature Rating : -30°C to 80°C
- B. Circuit Rating : 12V,10mA(MAX20mA)

## 3.4 Performance Requirements and Test Descriptions:

The product shall be designed to meet the electrical, mechanical and environmental performance requirements specified in Fig.1 and Fig.2. All tests shall be performed in the room temperature, unless otherwise specified.

3.5 Test Requirements and Procedures Summary:

Para.	Test Items	Requirements	Procedures
3.5.1	Examination of Product	Meets requirements of product drawing and AMP Specification 114-5270	Visually inspection. No physical damage.
Electrical Requirements			
3.5.2	Termination Resistance (Low Level)	(1)FPC-contacts.12.0mV Max (2)TOTAL.36.0mV Max	Measure resistance of the contacts with crimped FPC and wire in open circuit at 20mV and close circuit at 12mA. Fig.3 AMP Spec.109-5311-1
3.5.3	Dielectric with-standing Voltage	No creeping discharge nor flash-over shall occur.	Measure between the adjacent contacts. 1kV AC for 1 minute. Fig.4 AMP Spec. 109-5301
3.5.4	Insulation Resistance	100M $\Omega$ Min. (Initial) 100M $\Omega$ Min. (Final)	Impressed voltage 500V DC Fig.4 AMP Spec. 109-5302
3.5.5	Current leakage	100 $\mu$ A Max	After leave connector at 60°C/1hour, immerse connector in normal temperature water of deep 15cm. Supply 12V DC to adjacent contacts.
Mechanical Requirements			
3.5.6	FPC crimp tensile strength.	15.0N Max.(Initial) 15.0N Max.(Final)	Fix the contact and then,pull at the FPC to axis direction. Operation speed : 100mm/min.
3.5.7	FPC tensile strength.	100.0N Min(Initial) 90.0N Min(Final)	Fix the housing and then,pull at the FPC to axis direction. Operation speed : 100mm/min.
3.5.8	Wire crimp tensile strength.	0.3mm <sup>2</sup> : 58N Min. 0.5mm <sup>2</sup> : 88N Min.	Apply an axial pull-off load to crimped wire of the contact secured on the tester. Operation Speed : 100mm/min. AMP Spec. 109-5205 Operation Speed : 100mm/min.
3.5.9	Diode crimp tensile strength.	40N Min.	Apply an axial pull-off load to crimped wire of the contact secured on the tester. Operation Speed : 100mm/min. AMP Spec. 109-5205 Operation Speed : 100mm/min.

Fig.1 (To be continued)

Para.	Test Items	Requirements	Procedures
3.5.10	Wire tensile strength.	100.0N Min.(Initial) 100.0N Min(Final)	Fix the housing and then,pull at the wire to axis direction. Operation Speed : 100 mm/min.
3.5.11	Vibration (High frequency)	36mV Max. (Final) No electrical discontinuity greater than 1 $\mu$ sec. shall occur.	Vibration Frequency : 20°C →200→20Hz/ 3min (Log) Accelerated Velocity : 44.1m/s <sup>2</sup> (4.5G) Vibration Direction : X,Y,Z Duration : 9hours(each 3hours)
3.5.12	Compound Environment Resistance	36mV Max. (Final) No electrical discontinuity greater than 1 $\mu$ sec. shall occur.	Vibration Frequency : 20°C →200→20Hz/ 3min (Log) Accelerated Velocity : 44.1m/s <sup>2</sup> (4.5G) Vibration Direction : X,Y,Z Duration : 300hours(each 100hours) Test current cycle : 12mA 45min ON/15min OFF
Environmental Requirements			
3.5.13	Temperature Life (Heat Aging)	36mV Max. (Final)	100±3°C, Duration : 120hours
3.5.14	Thermal shock	36mV Max. (Final)	-30°C/30min. 80°C/30min. Making this a cycle, repeat 300cycles.
3.5.15	Water splash	Insulation resistance 100M $\Omega$ Min. (Final) Termination resistance 36mV Max. (Final) Current leakage 100 $\mu$ A Max.(Final)	80°C for 40min,splash water for 20min. Making this a cycle, repeat 20 cycles, test voltage 12V. AMP Spec.109-5109 During the test,test voltage of 12V DC is applied between the adjacent contacts,and monitor the circuit for electrical current leakage.
3.5.16	Resistance to Cold	36mV Max. (Final)	-30±3°C, 120hours
3.5.17	Humidity, Steady State	Insulation resistance 100M $\Omega$ Min. (Final) Termination resistance 36mV Max. (Final)	85±3%R.H. 80±3°C 300hours

Fig.1 (End)

3.6 Product Qualification Test Sequence

Para.	Test Examination	Test Group									
		1	2	3	4	5	6	7	8	9	10
		Test Sequence <sup>(1)</sup>									
3.5.1	Examination of Product	1	1	1	1	1	1	1	1,4	1,4	1,4
3.5.2	Termination Resistance (Low Level)						2		2,5	2,5	2,5
3.5.3	Dielectric withstanding Voltage						4				7
3.5.4	Insulation Resistance						3				6
3.5.5	Current Leakage							2			
3.5.6	FPC crimp tensile strength	2									
3.5.7	FPC tensile strength		2						6		
3.5.8	Wire crimp tensile strength			2							
3.5.9	Diode crimp tensile strength				2						
3.5.10	Wire tensile strength					2				6	
3.5.11	Vibration (High frequency)										
3.5.12	Compound Environment resistance										
3.5.13	Temperature Life (Heat Aging)								3	3	3
3.5.14	Thermal shock										
3.5.15	Water splash										
3.5.16	Resistance to Cold										
3.5.17	Humidity, Steady State										

Fig.2 (To be continued)

Para.	Test Examination	Test Group								
		10	11	12	13	14	15	16	17	18
		Test Sequence <sup>(1)</sup>								
3.5.1	Examination of Product	1,4	1,4	1,4	1,4	1,4	1,4	1,4	1,4	1,4
3.5.2	Termination Resistance (Low Level)	2,5	2,5	2,5	2,5	2,5	2,5	2,5	2	2,5
3.5.3	Dielectric withstanding Voltage	7	7	7	7					
3.5.4	Insulation Resistance	6	6	6	6					
3.5.5	Current Leakage								5	
3.5.6	FPC crimp tensile strength									
3.5.7	FPC tensile strength					6				
3.5.8	Wire crimp tensile strength									
3.5.9	Diode crimp tensile strength									
3.5.10	Wire tensile strength						6			
3.5.11	Vibration (High frequency)							3	3	
3.5.12	Compound Environment resistance									3
3.5.13	Temperature Life (Heat Aging)									
3.5.14	Thermal shock	3								
3.5.15	Water splash		3							
3.5.16	Resistance to Cold			3						
3.5.17	Humidity, Steady State				3	3	3			

(1) Number indicate sequence in which tests are performed.

Fig.2 (End)

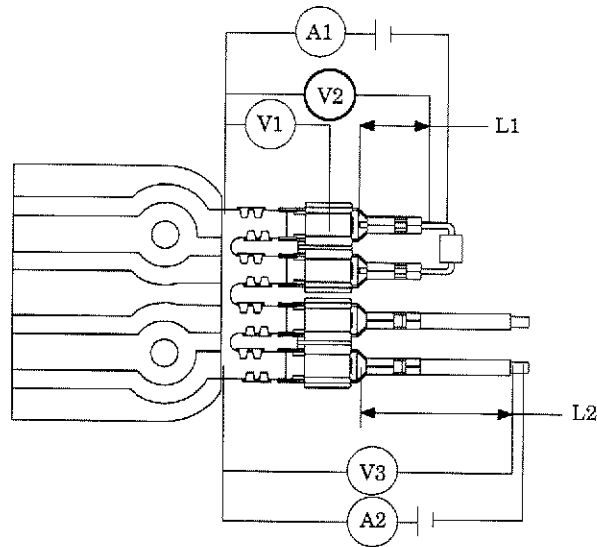

(V1) :FPC×Contact

(V2) (V3) :Total

\*Deduct the resistance of the diode "L1" and wire "L2" from the measured value V2 and V3

Fig.8

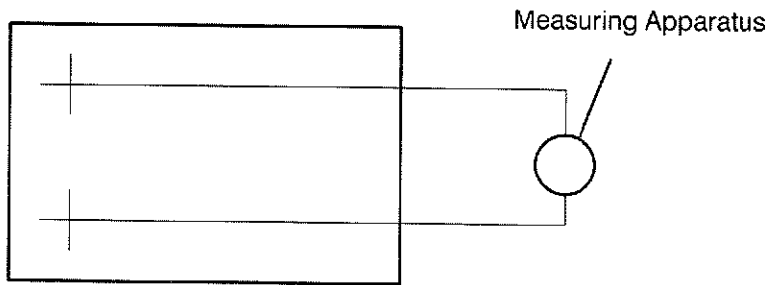

The adjacent contacts

Fig.4

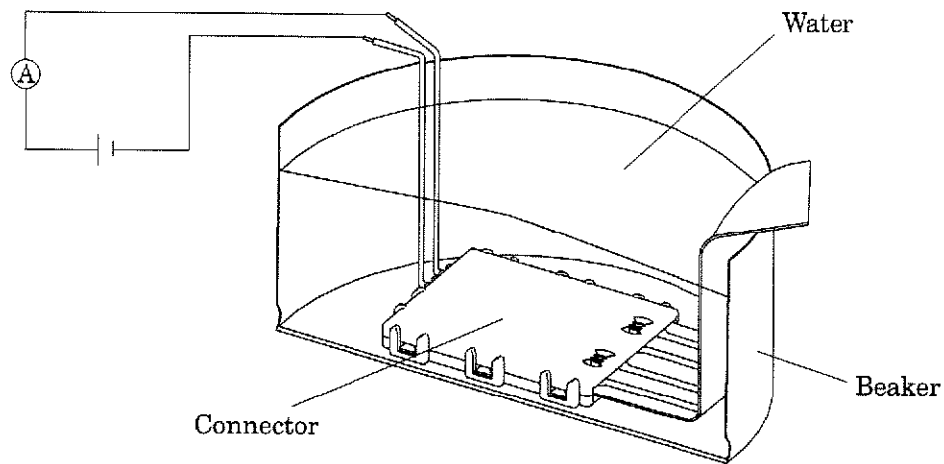

\* Immerse the connector in beaker filled with water

Fig.5

The applicable product descriptions and part numbers are as shown in Appendix. 1

Product Part No.	Description
1318523	Cover Housing Assembly
1318524	Cover Housing
353840	Pitch Plate
1318525	Seal Rubber (GEL)
353842	FPC Contact
1318526	FPC DIODE Contact

Appendix 1