

1. Scope :**1.1 Contents**

This specification covers the requirements for product performance, test methods and quality assurance provisions of Squib Connector.

Applicable product description and part numbers are as shown in Appendix. 1.

2. Applicable Documents :

The following documents form a part of this specification to the extent specified herein. In the event of conflict between the requirements of this specification and the product drawing, the product drawing shall take precedence.

2.1 AMP Specifications :

- | | |
|-------------|---|
| A. 109-5000 | Test Specification, General Requirements for Test Methods |
| B. 114-5234 | Application Specification, Squib Contact (Socket for ϕ 1 mm Pin) |
| C. 501-5254 | Test Report |

2.2 Commercial Standards and Specifications :

- | | |
|---------------|---|
| A. JASO D605 | Automotive Multi-Pole Connectors. |
| B. JASO D7101 | Test Methods for Molded Plastic Parts. |
| C. JIS C3406 | Low Voltage Cables for Automobiles. |
| D. JIS D0203 | Method of Moisture, Rain and Spray Test for Automobile Parts. |
| E. JIS D0204 | Method of High and Low Temperature Test for Automobile Parts. |
| F. JIS D1601 | Vibration Testing Method for Electronic Components. |
| G. JIS R5210 | Portland Cement |

3. Requirements :

3.1 Design and Construction :

Product shall be of the design, construction and physical dimensions specified on the applicable product drawing.

3.2 Materials :

A. Contact : Plain phosphor bronze with selective gold and tin-lead plating over nickel underplating.

B. Housing : Molded Polybutylene - Terephthalata (PBT)

C. Ferrite : Ferrite

3.3 Ratings :

A. Temperature Rating: -40°C to 105°C

3.4 Performance Requirements and Test Descriptions :

The product shall be designed to meet the electrical, mechanical and environmental performance requirements specified in Fig. 1. All tests shall be performed in the room temperature, unless otherwise specified.

3.5 Test Requirements and Procedures Summary :

Para.	Test Items	Requirements	Procedures
3.5.1	Examination of Product	Meets requirements of product drawing and AMP Specification 114-5234.	Visual inspection No physical damage
Electrical Requirements			
3.5.2	Termination Resistance (Low Level)	3 mΩ Max. (Initial) 10 mΩ Max. (Final)	Subject mated contacts assembled in housing to 20 mV Max. open circuit at 10 mA. Fig. 2. AMP Spec. 109-5311-1
3.5.3	Dielectric withstanding Voltage	No creeping discharge nor flashover shall occur.	1 kVAC for 1 minute. Test between adjacent circuits of unmated connectors. AMP Spec. 109-5301 Fig. 3.
3.5.4	Insulation Resistance	100 MΩ Min. (Initial)	Impressed voltage 500 V DC. Test between adjacent circuits of unmated connectors. AMP Spec. 109-5302 Fig. 3.
Mechanical Requirements			
3.5.5	Contact Mating Force	1.5~5 N	Operation Speed : 20~200 mm/min. Measure the force required to mate contact AMP Spec. 109-5206
3.5.6	Contact Unmating Force	0.5~5 N	Operation Speed : 20~200 mm/min. Measure the force required to unmate contact. AMP Spec. 109-5206
3.5.7	Connector Mating Force	70 N Max.	Operation Speed : 20~200 mm/min. Measure the force required to mate connectors. AMP Spec. 109-5206
3.5.8	Connector Unmating Force	15 N Min.	Operation Speed : 20~200 mm/min. Measure the force required to unmate connectors. AMP Spec. 109-5206

Fig. 1 (Cont)

Para.	Test Items	Requirements		Procedures
3.5.9	Contact Insertion Force	9.8 N Max. per contact.		Measure the force required to insert contact into housing. AMP Spec. 109-5211
3.5.10	Contact Retention Force (with LID)	98 N Min.		Measure contact retention force with LID set it effect. Operation Speed : 20~200 mm/min.
3.5.11	Crimp Tensile Strength	Wire Size		Crimp Tensile (min.)
		mm ²	(AWG)	
		0.3	22	59
		0.5	20	88
3.5.12	Resistance to "Kojiri"	Termination Resistance : 10 mΩ max. (Final)		Direction : Back & Forth Right & Left Force : 78 N Cycles : 10 cycles This test may be alternatively performed manually. AMP Spec. 109-5215
3.5.13	Handling Ergonomics	No abnormalities allowed in manual mating/unmating handling.		Manually operated
Environment Requirements				
3.5.14	Thermal Shock	10 mΩ Max. (Final)		Mated/Unmated connector - 30°C/30 min., 80°C/30 min. Making this a cycle, repeat 5 cycles. AMP Spec. 109-5103

Fig. 1 (Cont)

Para.	Test Items	Requirements	Procedures
3.5.15	Humidity, Steady State	Insulation resistance (Final) 100 M Ω Min. Termination resistance 10 m Ω Max. (Final) Current Leakage 3 mA max.	Mated/Unmated connector, 90~95% R.H. 60 $^{\circ}$ C 96 hours AMP Spec. 109-5105 Fig. 4
3.5.16	Industrial Gas (SO ₂)	10 m Ω Max. (Final)	Unmated connector SO ₂ Gas : 10 ppm, 95% R.H. 20 $^{\circ}$ C, 24 hours AMP Spec. 109-5107
3.5.17	Temperature Life (Heat Aging)	10 m Ω Max. (Final)	Mated connector 120 $^{\circ}$ C, Duration : 5 days AMP Spec. 109-5104
3.5.18	Resistance to Cold	10 m Ω Max. (Final)	Mated connector -40 $^{\circ}$ C \pm 3 $^{\circ}$ C, 120 hours AMP Spec. 109-5108
3.5.19	Dust Bombardment	10 m Ω Max. (Final)	Mated connector Subject JIS R 5210 cement blow of 1.5 kg per 10 seconds in 15 minutes intervals for 90 minutes. AMP Spec. 109-5110
3.5.20	Compound Environment	10 m Ω Max. (Final)	Test by fig condition Fig.5.

Fig. 1 (End)

2. Product Qualification Test Sequence

Test or Examination	Test Group									
	1	2	3	4	5	6	7	8	9	10
	Test Sequence (a)									
Examination of Product	1									
Termination Resistance (Low Level)										
Dielectric withstanding Voltage										
Insulation Resistance										
Connector Mating Force							1			
Connector Unmating Force								1		
Contact Insertion Force										1
Contact Retention Force (Double Lock)					1					
Contact Mating Force		1								
Contact Unmating Force			1							
Crimp Tensile Strength				1						
Housing Locking Strength									1	
Resistance to "Kojiri"										
Handling Ergonomics							1			
Compound Environment										
Thermal Shock										
Humidity (Steady State)										
Temperature Life (Heat Aging)										
Resistance to Cold										
Dust Bombardment										
Industrial SO ₂ Gas										

(a) Numbers indicate sequence in which tests are performed.

Test or Examination	Test Group										
	11	12	13	14	15	16	17	18	19	20	21
	Test Sequence (a)										
Examination of Product											
Termination Resistance (Low Level)	1			1, 3	1, 3	1, 3	1, 3	1, 3	1, 3	1, 3	1, 3
Dielectric withstanding Voltage			1								
Insulation Resistance		1									
Connector Mating Force											
Connector Unmating Force											
Contact Insertion Force											
Contact Retention Force (Double Lock)											
Contact Mating Force											
Contact Unmating Force											
Crimp Tensile Strength											
Housing Locking Strength											
Resistance to "Kojiri"				2							
Handling Ergonomics											
Compound Environment										2	
Thermal Shock							2				
Humidity (Steady State)									2		
Temperature Life (Heat Aging)					2						
Resistance to Cold						2					
Dust Bombardment								2			
Industrial SO ₂ Gas											2

(a) Numbers indicate sequence in which tests are performed.

The applicable product descriptions and part numbers are as shown in Appendix. 1.

Product Part No.	Description
353376	Squib Contact (Socket for ϕ 1 mm Pin)
353377	Squib Connector Housing (Main)
353378	Squib Connector Housing (LID)
353379	Squib Connector Ferrite

Appendix. 1

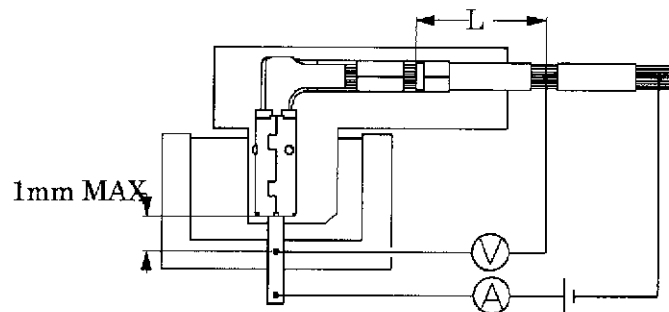

Deduct the resistance of the wire "L" from the measured value
 The contact point with meter should be soldered.

Fig.2

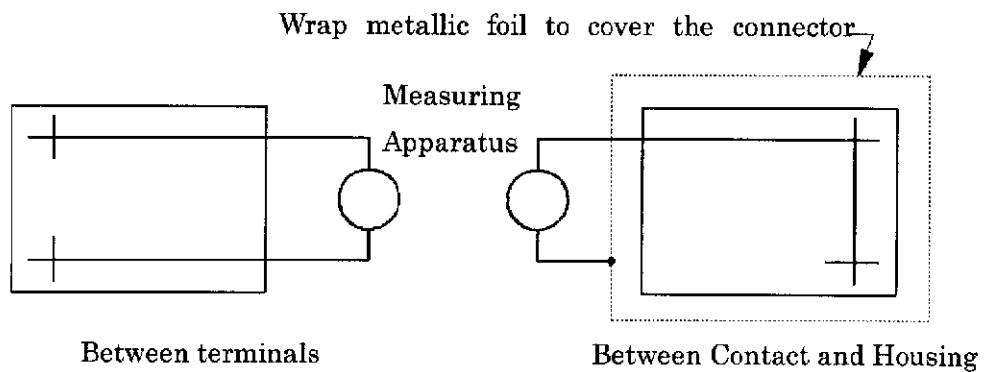

Between terminals

Between Contact and Housing

Fig.3

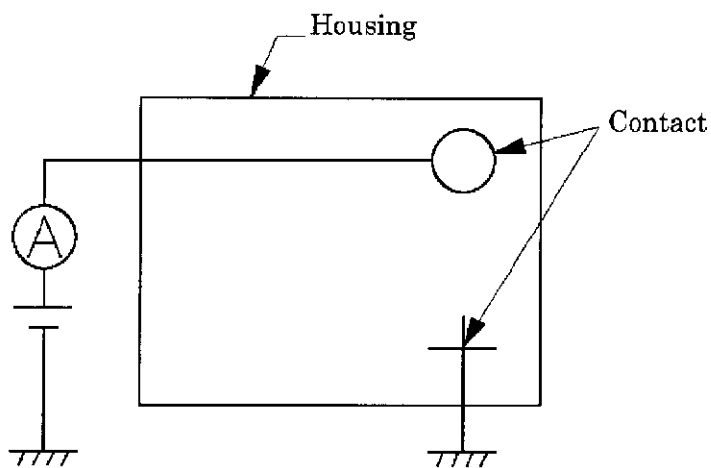

Fig.4

Temperature $80 \pm 3^{\circ}\text{C}$

Short circuit current

Short circuit current	Judgment on dropout
10mA	1ms Min.

Period 300 hours

(The directions of vibration shall be back and forth, left and right, and up and down simultaneously.)

Vibration Vibration frequency : 20~200~20Hz
Sweep time ; 3min.

Acceleration : 44.1m/s^2 (4.5G)

AMP Spec. : 109-5202

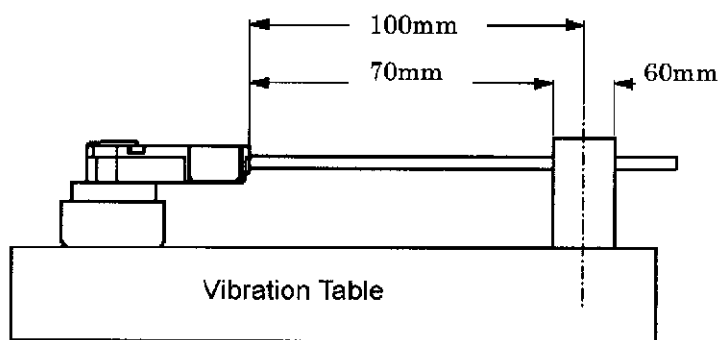

Fig.5