

Design Objectives

This product described in this document has not been fully tested to insure conformance to the requirements outlined below. Therefore, AMP do Brasil makes no representation or warranty, express or implied, that the product will comply with these requirements. Further, AMP do Brasil may change these requirements based on the results of additional testing and evaluation. Contact AMP Engineering for further details.

1. SCOPE**1.1 Content**

This specification covers the performance, tests and quality requirements for the AMP Superseal connectors 280/630 Series for automotive vehicles.

1.2 Qualification

When tests are performed on the subject product line, the procedures specified in AMP 109 Series Specifications shall be used. All inspections shall be performed using the applicable inspection plan and product drawing.

2. APPLICABLE DOCUMENTS

The following documents form a part of this specification to the extent specified herein. In the event of conflict between the requirements of this specification and the product drawing, the product drawing shall take precedence. In the event of conflict between the requirements of this specification and the referenced documents, this specification shall take precedence.

2.1 AMP Documents

- | | | |
|----|---------------------------|---|
| a) | 109-1 (Rev "C") | General Requirements for Test Specifications |
| b) | 109 Series | Test Specifications as indicated in Figure 1. (Comply with MIL-STD-202, Rev C Apr 80, MIL-STD-1344 Rev 31 Oct 73 and EIA RS-364 Rev 17 Aug 71). |
| c) | Corporate Bulletin 401-76 | Cross-reference between AMP Test Specifications and Military or Commercial Documents. |
| d) | 108-18013 (Rev "D") | Jr. Power Timer Specification |
| e) | 108-18025 (Rev "0") | Std Power Timer Specification |

3. PRODUCT PART NUMBERS AND DESCRIPTIONS

The products of the following part numbers shall be governed under this specification.

Prepared by : X.P.Jarefo

Approved by : R.Indriksons

AMP do Brasil Conectores Elétricos e Eletrônicos Ltda

© Copyright 1995 by AMP do Brasil Ltda.
All international rights reserved.• Trademark
| Indicates changesThis specification is a controlled document.
For latest revision, call the AMP FAX.

1 of 7

Loc. AP

Part Number	Description
444230	Ass'y 2posn, 6,3 Series, Std Power Timer
444234	Ass'y 1posn, Jr. Power Timer Rec
444238	Ass'y 1posn, Jr. Power Timer Tab
444241	Ass'y 2posn, Jr. Power Timer Rec
444245	Ass'y 2posn, Jr. Power Timer Tab
444248	Ass'y 3posn, Jr. Power Timer Rec
444252	Ass'y 3posn, Jr. Power Timer Tab
444255	Ass'y 3posn, .110 Relay Rec

Note : See customer drawings for mating part information .

4. REQUIREMENTS

4.1 Design and Construction

Product shall be of the design , construction and physical dimensions specified on the applicable product drawing .

4.2 Materials

a)	Housing	Polyamide 6,6
b)	Connector Seal	Silicone Rubber
c)	Wire Seal	Silicone Rubber
d)	Contacts	Jr. Power Timer Contact - Phosphor Bronze Std Power Timer Contact - Phosphor Bronze .110 Relay Rec. Contact - Brass

4.3 Ratings

a)	Temperature	-40°C to 80°C (based on material) .
b)	Cable Range and Test Current.	

Contact P/N Rec. Tab	Contact Description	Wire Range (mm ²)	Insulat. Dia (mm)	Wire Seal P/N	Test Current	
					Wire Size (mm ²)	A
927770-3 962915-1	Jr. P. Timer	0,5 - 1,0	1,4 - 2,1	828904-1	0,5 1,0	6 11
927766-3 962916-1	Jr. P. Timer	1,0 - 2,5	1,9 - 3,0	828905-1	1,5 2,0 2,5	14 16 20
928966-2 -----	Std. P. Timer	2,5 - 4,0	2,8 - 3,7	963245-1	2,5 3,0 4,0	20 23 28
444259-2 -----	.110 Relay Rec.	1,0 - 2,5	1,9 - 3,0	828921-1	1,5 2,0 2,5	14 16 20

Table 1

4.4 Performance and Test Description

The product is designed to meet the electrical , mechanical and environmental performance requirements specified in Figure 1 . All tests are performed at ambient environmental conditions per AMP Specification 109-1 (Rev "C") unless otherwise specified .

4.5 Test Requirements and Produce Summary

Test Description	Requirements		Procedure
Electrical			
Examination of Product	Meets requirements of product drawing		Visual, dimensional and functional per applicable quality inspection plan .
Voltage Drop	6m V/A maximum.		Measure potential drop of mated contacts . See table 1 for the wire sizes and test currents ; AMP Spec. 109-25 (Rev "B") .
Termination Resistance	3m Ω maximum.		Subject mated contacts to 100 mA ; AMP Spec. 109-6-1 (Rev "F").
Dielectric Withstanding Voltage	No break down or flash-over when 1KVAC is applied for one minute.		Test between adjacent contacts of mated connector assembly; AMP Spec. 109-29-1 (Rev "D").
Insulation Resistance	200 megohms minimum.		Test between adjacent contacts of mated connector assembly; AMP Spec. 109-28-4 (Rev "B").
Current Cycling	See note (a).		Subject mated contacts to cycles at rated current for 45 minutes "on" - 15 minutes "off" ; AMP Spec. 109-51; cond. "B", test method 4 , (Rev "A") , test wire range : A. for SPT hsg: 4mm ² B. for JPT and .110 Relay Recep.: 2,5mm ² .
Temperature Rise x Current	At = 50°C max. temperature rise at specified current.		Measure temperature rise vs. current ; AMP Spec. 109-45-1(Rev "B"). Test current : maximum current for each contact - see table 1 .
Mechanical			
Vibration Sinusoidal High Frequency	No discontinuities greater than 1 microsecond. See note (a).		Subject mated connector to frequency range between 10 to 500 Hz and back to 10 Hz with speed equal to one octave per minute . Subject to a simple harmonic motion having displacement of 2mm peak to peak , 2 hours in each of 3 mutually perpendicular plane . (See figure 3) .
Mating Force	1posn: 60N max. 2posn: 70N max. 3posn: 85N max.		Measure force necessary to mate connector assembly with locking latches at a rate of 25mm/min ; AMP Spec 109-42 ; cond "A" (Rev "A").
Unmating Force	1posn: 15N max. 2posn: 25N max. 3posn: 35N max.		Measure force necessary to unmate connector assembly with locking latches removed a released at a rate of 25mm/min . ; AMP Spec. 109-42 ; cond. "A" , (Rev "A").
Contact Retention	60N min.		Apply axial load of 60N to contacts in the axial direction ; AMP Spec 109-30 (Rev "C").
Crimp Tensile	Wire Size mm ²	Force N(Min)	Determine crimp tensile at a rate of 25 mm/min; AMP Spec. 109-16 (Rev "A").
	0,5	60	
	1,0	100	
	1,5	150	
	2,5	200	
	4,0	300	
Spacer Mating Force	40N maximum.		Measure force necessary to mate spacer in the secondary lock . Housing with terminals.

Contact Engaging Force	18N maximum.	Measure force to engage the tab into receptacle contact. For the .110 Relay Rec. contact, use the tab shown at figure 4.
Contact Disengaging Force	5N minimum.	Measure force to disengage the tab from rec. contact. For the .110 Relay Rec. contact, use the tab shown at figure 4.
Environmental		
Thermal Shock	See note (a).	Subject mated connectors to : 14 cycles each consisting of : - 16 hours at $40 \pm 2^{\circ}\text{C}$ 90 - 95% humidity - 2 hours at $-40 \pm 2^{\circ}\text{C}$ - 2 hours at $125 \pm 2^{\circ}\text{C}$ - 4 hours at $23 \pm 5^{\circ}\text{C}$ (max time to change cond 3min) 15th cycle: exposure for 24 hours at $40 \pm 2^{\circ}\text{C}$, 90 - 95% humidity.
Temperature Life	See note (a).	Subject mated connectors to temperature life at 125°C for 96 hours duration ; AMP Spec. 109-43 (Rev "B").
Water Resistance Dynamic Immersion	See note (a).	Immerse mated connectors in water with 5% NaCl, 10cm below the water level at $23 \pm 5^{\circ}\text{C}$. Pull the wire with a force between 1,5 and 2,5N (see figure 5). 500.000 cycles max. frequency : 50 cycles / min.
Salt-spray corrosion	See note (a).	Subject mated connectors to 5% NaCl concentration for 150 hours ($35 \pm 2^{\circ}\text{C}$).
Chemical Resistivity	See note (a).	Subject mated connectors to 3 minutes immersion in : - brake fluid dot 3 at $50 \pm 3^{\circ}\text{C}$ - anti-freeze fluid at $23 \pm 5^{\circ}\text{C}$ - transmission and engine oil at $100 \pm 3^{\circ}\text{C}$ - cleaner fluid at $23 \pm 5^{\circ}\text{C}$ - gasoline at $23 \pm 5^{\circ}\text{C}$ - diesel fluid at $23 \pm 5^{\circ}\text{C}$ - alcohol at $23^{\circ} \pm 5^{\circ}$
Water-tight Sealing	See note (a).	According to IEC 529 (Rev 1989) IP x.4.
Water Resistance : Static Immersion	See note (a).	Subject mated connectors to 5 cycles : - 30 min at $+125 \pm 5^{\circ}\text{C}$ - 30 min immersed in water with 5% NaCl, 10cm below the water level at $23 \pm 5^{\circ}\text{C}$.

Figure 1

Note (a) : Shall meet visual requirements, show no physical damage, and shall meet requirements of additional tests as specified in Test Sequence in Figure 2.

5. TEST SEQUENCE

All the tests shall be performed in the sequence specified in Figure 2.

Note : Numbers indicate sequence in which tests shall be performed.

Test Description	Groups and Sequence								
	A	B	C	D	E	F	G	H	I
Examination of Product	1,5	1,5	1,9	1,5	1,13	1,13	1,8	1,10	1,5
Voltage Drop	2,4		2,8		2,11	2,11	2,7		
Termination Resistance		2,4							
Dielectric Withstanding Voltage					3,10	3,10		2,8	
Insulation Resistance				2,4	4,9	4,9	3,6	3,7	2,4
Current Cycling		3							
Temperature Rise vs. Current	3								
Vibration			4						
Mating Force					7	7		5	
Unmating Force					8	8		6	
Contact Retention			8		12	12		9	
Crimp Tensile		6							
Spacer Mating Force			3						
Contact Engaging Force			5						
Contact Disengaging Force			7						
Thermal Shock					5				
Temperature Life						5			
Water Resistance Dynamic Immersion				3	6(*)	6(*)			
Salt Spray Corrosion							5		
Chemical Resistivity								4	
Water Tight Sealing							4		
Water Resistance Static Immersion									3

Figure 2

(*) 10,000 cycles only.

6. QUALITY ASSURANCE PROVISIONS

6.1 Qualification Testing

Connector housings and contacts shall be prepared in accordance with applicable Instructions Sheets. They shall be selected at random from current production. Each group of the sample contacts shall consist of more than 30 sets of prepared contacts and connector sample group shall consist of more 5 sets of assembled connectors.

6.2 Requalification Testing

If changes significantly affecting form, fit or function are made to the product or to the manufacturing process, product assurance shall coordinate requalification testing consisting of all or part of the original testing sequence as determined by Product Engineering.

6.3 Acceptance

Acceptance is based on verification that the product meets the requirements of Figure 2. Failures attributed to equipment, test set-up or operator deficiencies shall not disqualify the product. When product failure occurs, corrective action shall be taken and samples resubmitted for qualification. Testing to confirm corrective action is required before resubmitted.

6.4 Quality Conformance Inspection

The applicable AMP Quality Inspection Plans will specify the sampling acceptable quality level to be used. Dimensional and functional requirements shall be in accordance with the applicable product drawing and this specification.

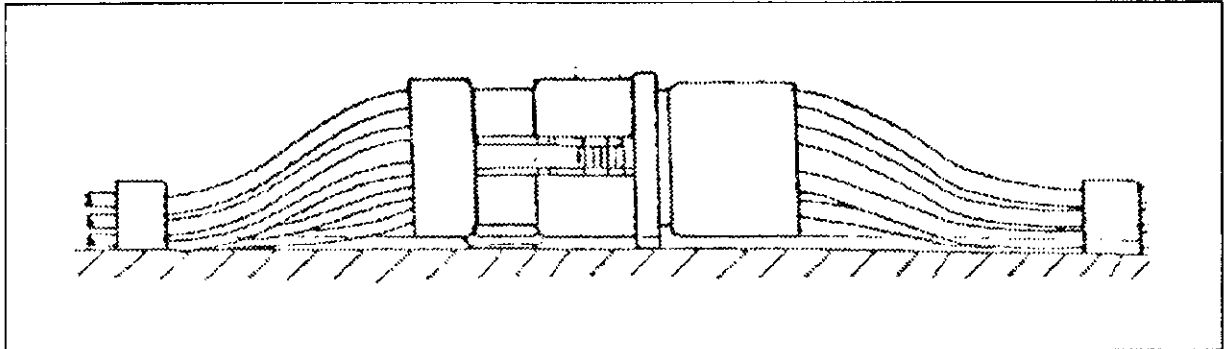

Figure 3
Vibration Scheme

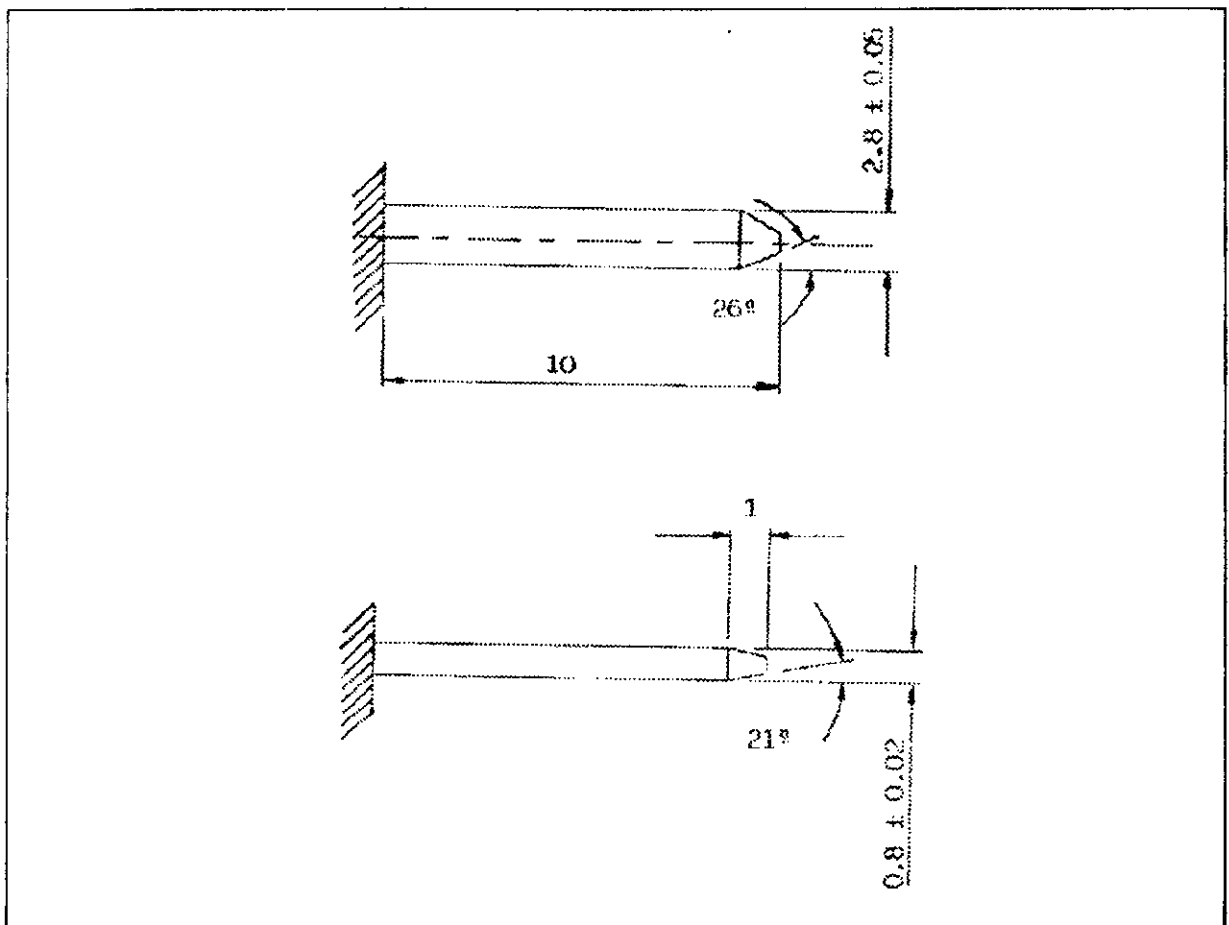

Figure 4
Tab Information for the .110 Relay Rec. Contact

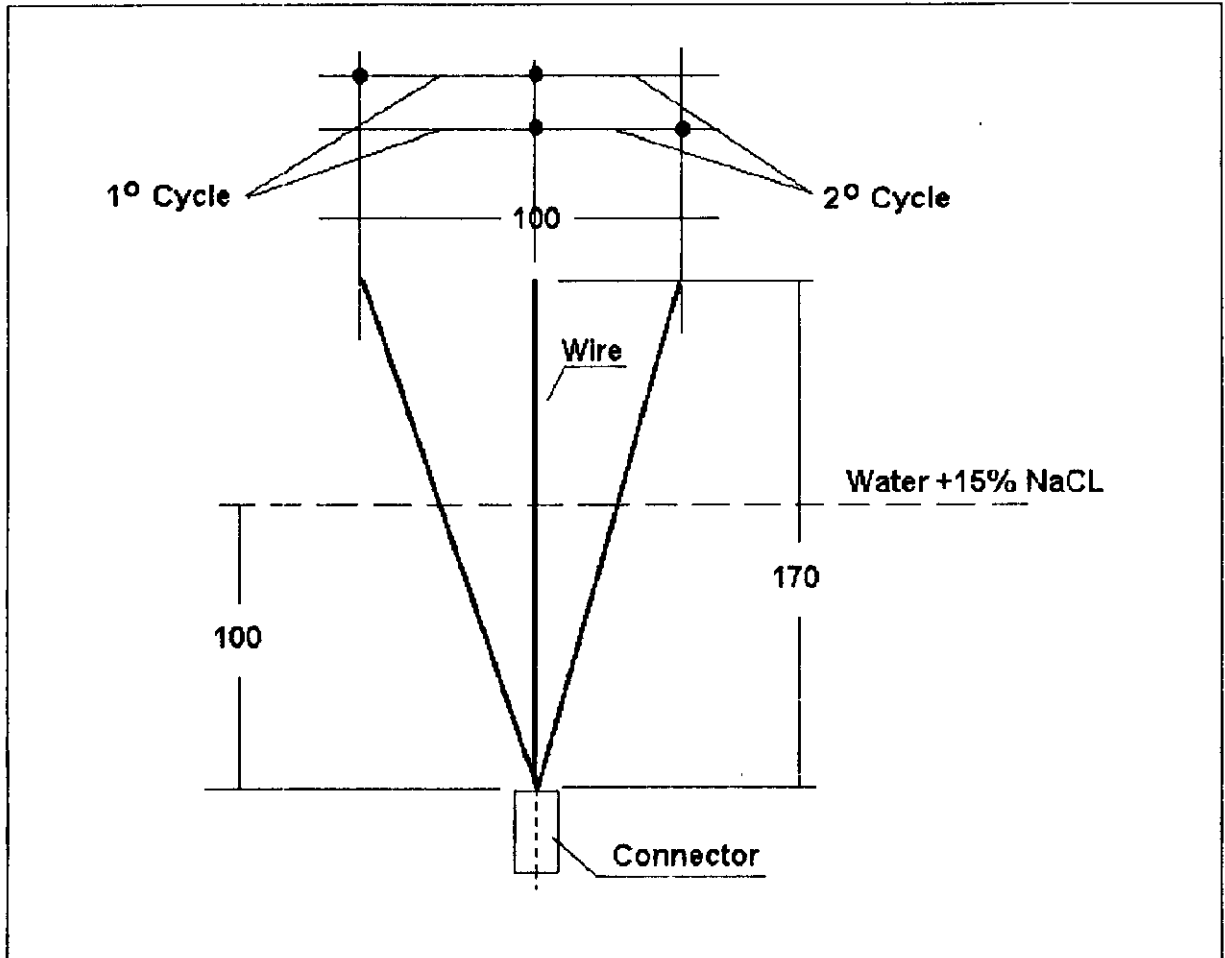

Figure 5
 Test Scheme of the Water Resistance - Dynamic Immersion

Revision Record		
Revision	Date	Description
O	19-May-94	Release
A	09-Aug-95	Revised by EC LB00-0380-95