

LOC		DIST		REVISIONS			
ES		00		REV	DATE	BY	APPV
1				INITIAL RELEASED	10APR2013	ML	SZ

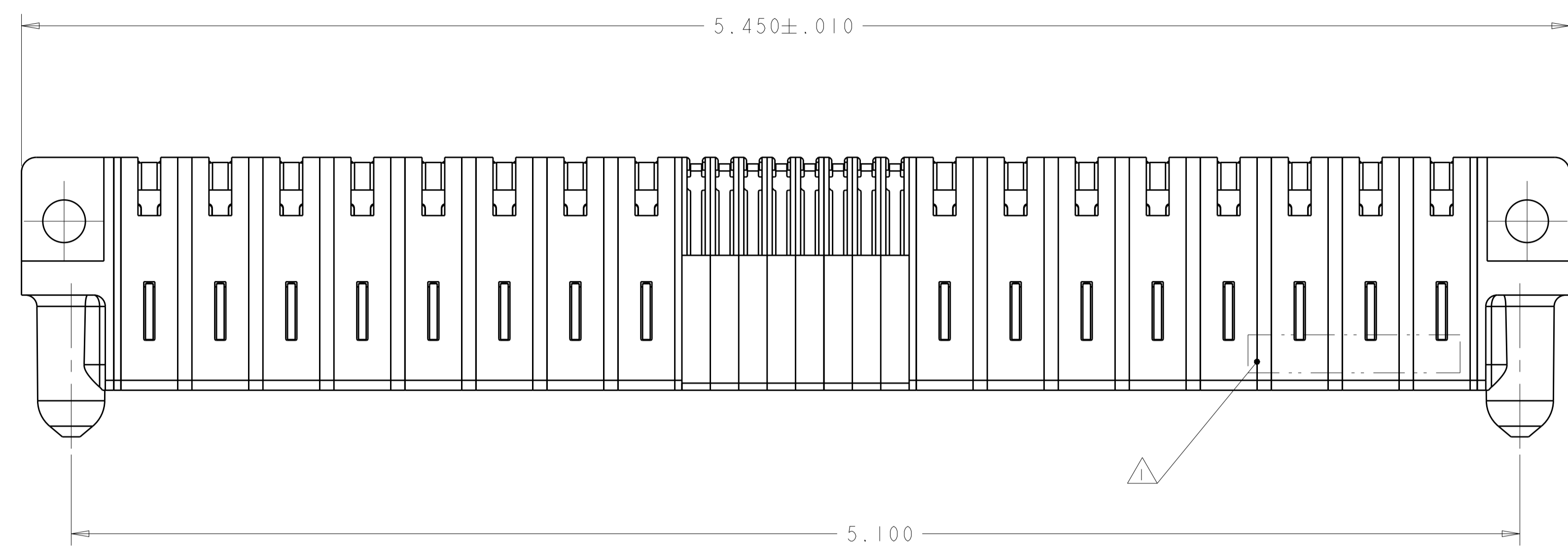

- 1 "AMP", PART NUMBER, AND DATE CODE TO BE MARKED IN AREA SHOWN
- 2 MATERIAL: HOUSING - GLASS FILLED HIGH TEMP THERMO PLASTIC, UV94 V-0
 SIGNAL CONTACT - COPPER ALLOY
 POWER CONTACT - HIGH CONDUCTIVITY COPPER ALLOY
- 3 CONTACT PLATING: SIGNAL CONTACTS -.000050 MIN Ni UNDER ALL
 .000030 MIN Au ON CONTACT AREA
 .000100 MIN Sn AT PCB INTERFACE
 POWER CONTACTS -.000050 MIN Ni UNDER ALL
 .000030 MIN Au ON CONTACT AREA
 .000100 MIN Sn AT PCB INTERFACE
- 4 MECHANICAL CONNECTOR KEEP OUT ZONE
- 5 DATUM AND BASIC DIMENSIONS ESTABLISHED BY CUSTOMER
- 6 PCB - ALL HOLE DIAMETERS ARE FINISHED HOLE SIZES
- 7 PCB - .0453 ± .0010 DRILLED HOLE PLATED WITH .0003 MIN Sn
 OVER .001-.003 PLATING TO ACHIEVE A .040 HOLE

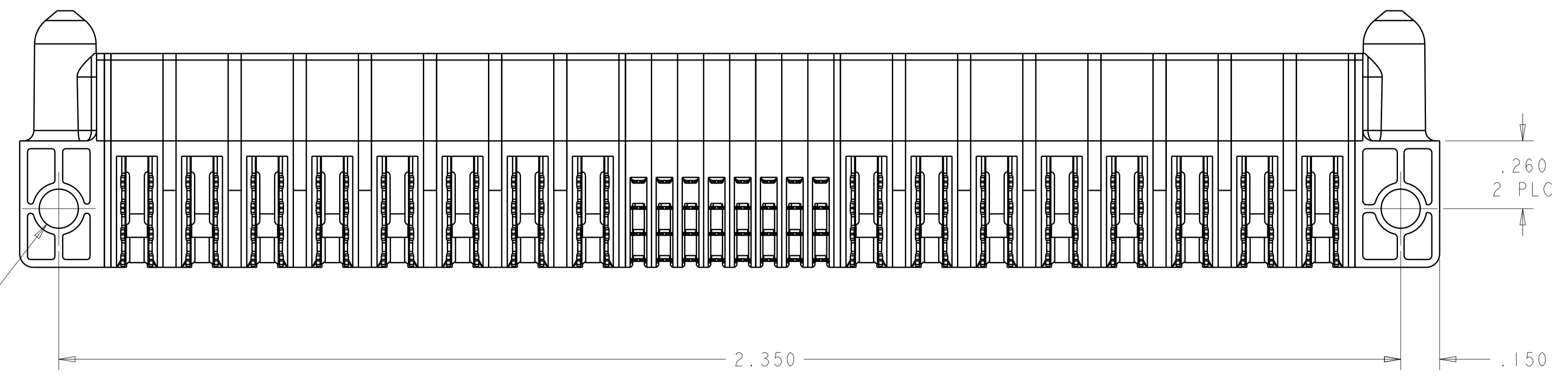
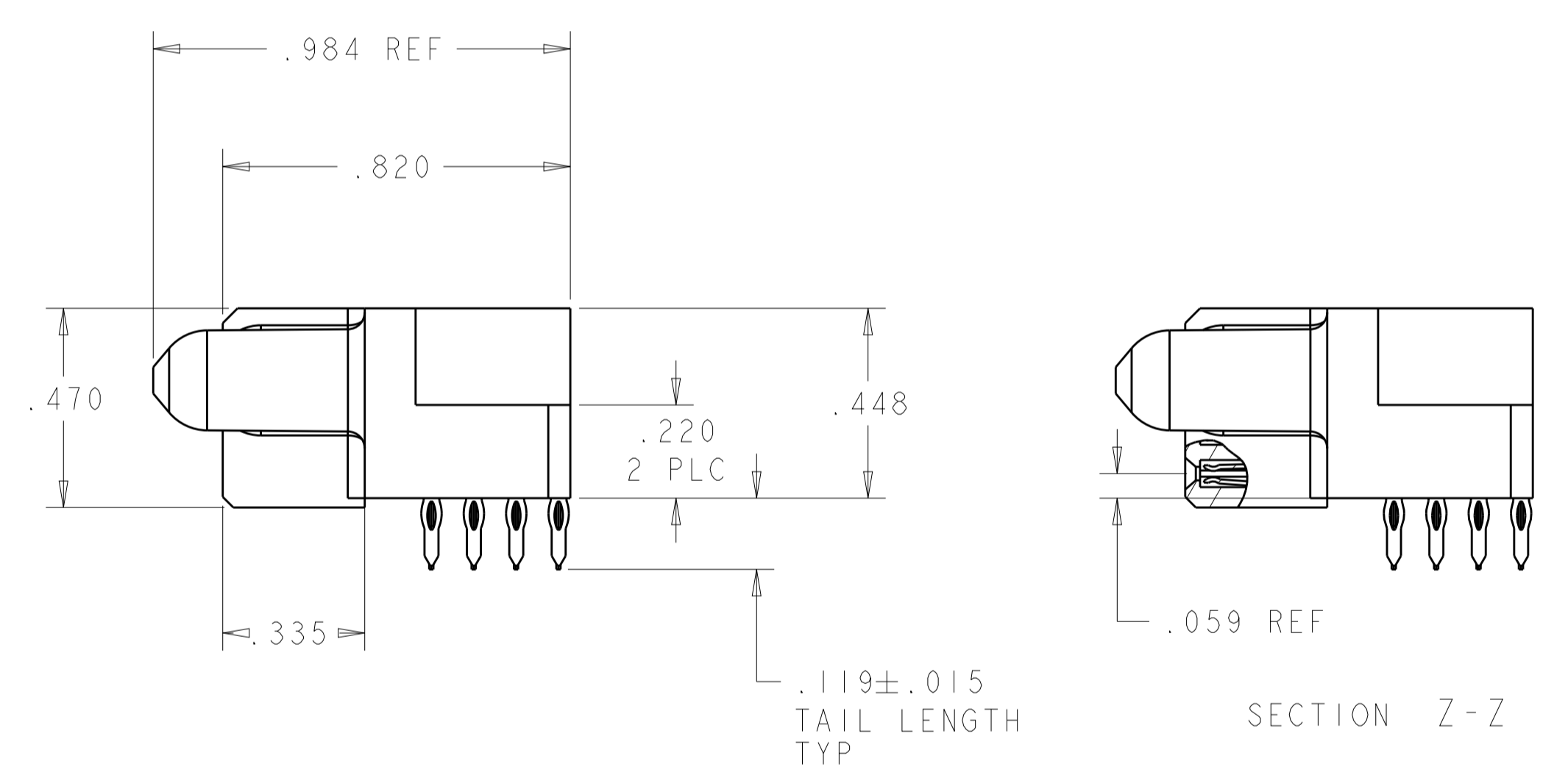
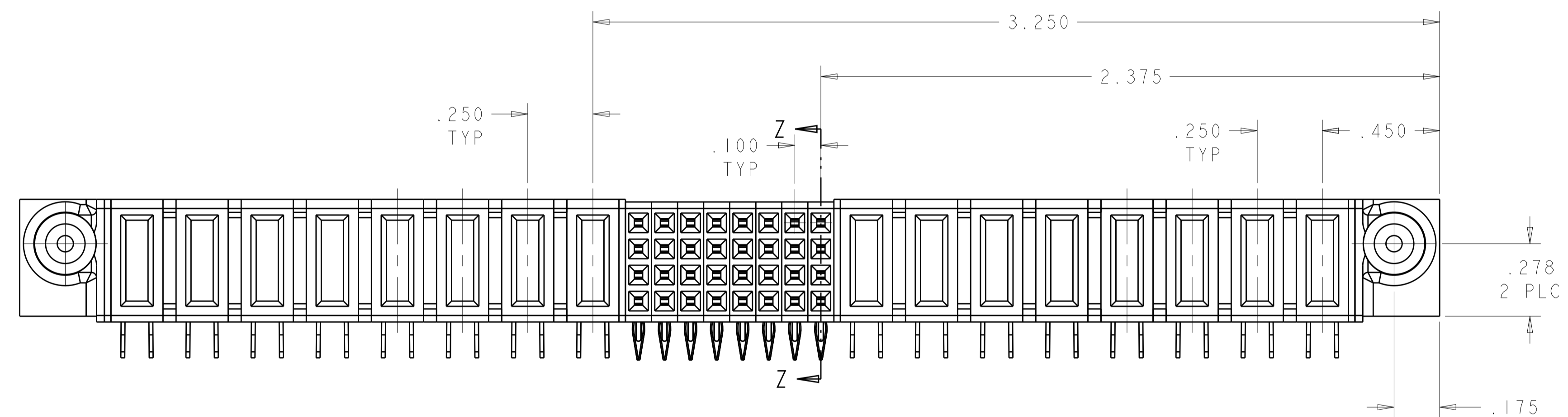

8P + 32S + 8P	1-2204147-6
DESCRIPTION	PART NUMBER

THIS DRAWING IS A CONTROLLED DOCUMENT.		OWN: MAC LIU 10APR2013	TE Connectivity
DIMENSIONS: INCHES		CHK: SUNY ZHAO 10APR2013	
TOLERANCES UNLESS OTHERWISE SPECIFIED:		APVD: SUNY ZHAO	NAME: RIGHT ANGLE RECEPTACLE ASSEMBLY W/GUIDES, PRESS FIT MULTI-BEAM XL
0 PLC ± .01	1 PLC ± .01	PRODUCT SPEC: 108-1973	SIZE: 114-13038
2 PLC ± .005	3 PLC ± .005	APPLICATION SPEC: 114-13038	RESTRICTED TO: A100779
4 PLC ± .0020	ANGLES ± .020	WEIGHT: -	SCALE: 4:1
MATERIAL: 2	FINISH: 3	Customer Drawing	SHEET 1 OF 2

LOC	DIST	REVISIONS			
P	LTN	DESCRIPTION	DATE	DMN	APVD
-	-	SEE SHEET 1	-	-	-

PART NUMBER	ROWS	POWER								SIGNAL								POWER							
		P16	P15	P14	P13	P12	P11	P10	P9	8	7	6	5	4	3	2	1	P8	P7	P6	P5	P4	P3	P2	P1
1-2204147-6	D	RS	RS	RS	RS	RS	RS	RS	RS	D	D	D	D	D	D	D	D	RS	RS	RS	RS	RS	RS	RS	RS
	C									C	C	C	C	C	C	C									
	B									B	B	B	B	B	B	B									
	A									A	A	A	A	A	A	A									
8P + 32S + 8P																									

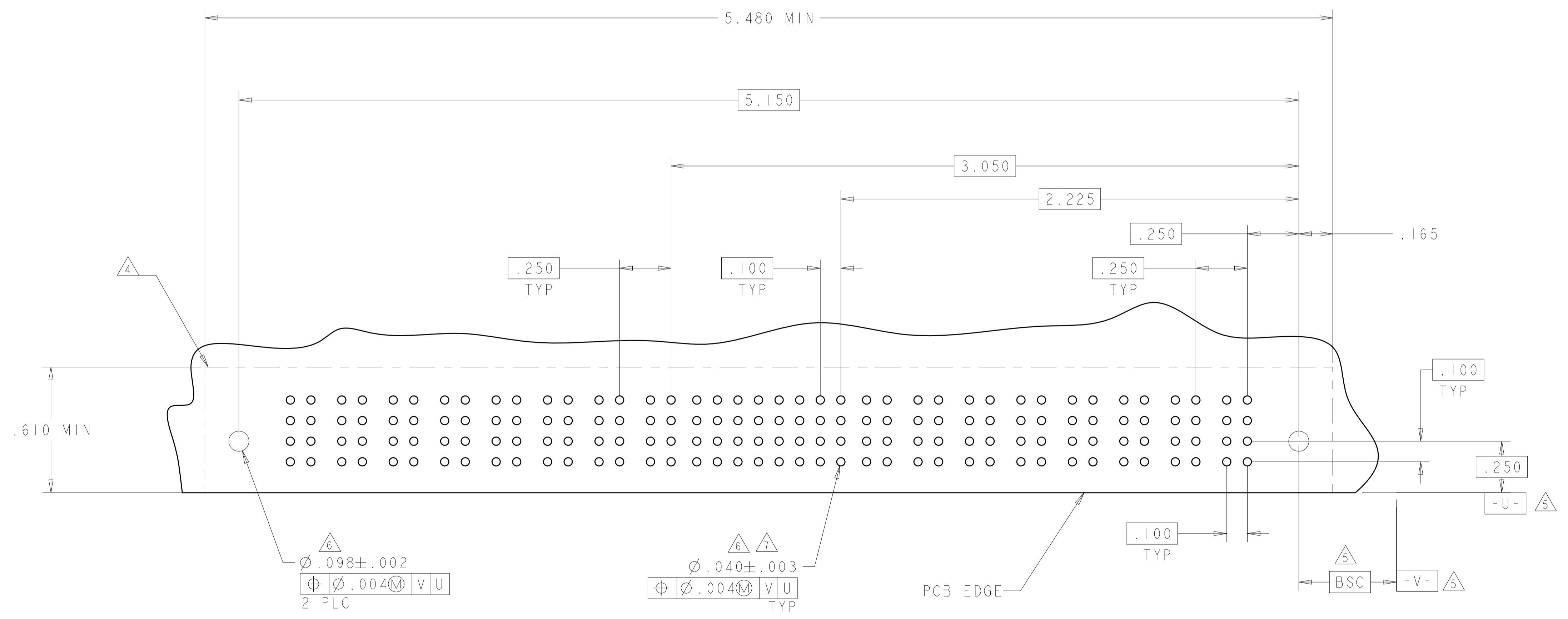

CODE	DESCRIPTION	ROW
D	SIGNAL CONTACT, R/A HDR, STD	D
C	SIGNAL CONTACT, R/A HDR, STD	C
B	SIGNAL CONTACT, R/A HDR, STD	B
A	SIGNAL CONTACT, R/A HDR, STD	A
RS	POWER CONTACT, R/A HDR, STD	-

THIS DRAWING IS A CONTROLLED DOCUMENT.

DMN: MAC LIU 10APR2013
 CHK: SUNY ZHAO 10APR2013

APVD: SUNY ZHAO

NAME: RIGHT ANGLE RECEPTACLE ASSEMBLY W/GUIDES, PRESS FIT MULTI-BEAM XL

PRODUCT SPEC: 108-1973
 APPLICATION SPEC: 114-13038

SIZE: 114-13038
 WEIGHT: -

MATERIAL: -
 FINISH: -

Customer Drawing

SCALE: 4:1 SHEET 2 OF 2 REV 1