

1. PRODUCT NAME AND MODEL NUMBER

This product is called the Mini Multi Lock Connector (temporary name), which consists of the components shown in Tables 1 and 2.

1.1 Housing

Model No.	Name
2822343	7-pin plug housing assembly (Waterproof)
2822344	7-pin cap housing assembly (Waterproof)
353899	7-pin plug housing assembly (Non-Waterproof)
353900	7-pin cap housing assembly (Non-Waterproof)

Table 1

1.2 Contact

Model No.	Name	Applicable wire		
		Wire Type	0.3	0.5
917308	Receptacle contact	CAVS	○	○
		AVSS	○	○
		AVSS F	○	○
917309	Tab Contact	CAVS	○	○
		AVSS	○	○
		AVSS F	○	○

Table 2

2. PRODUCT STRUCTURE

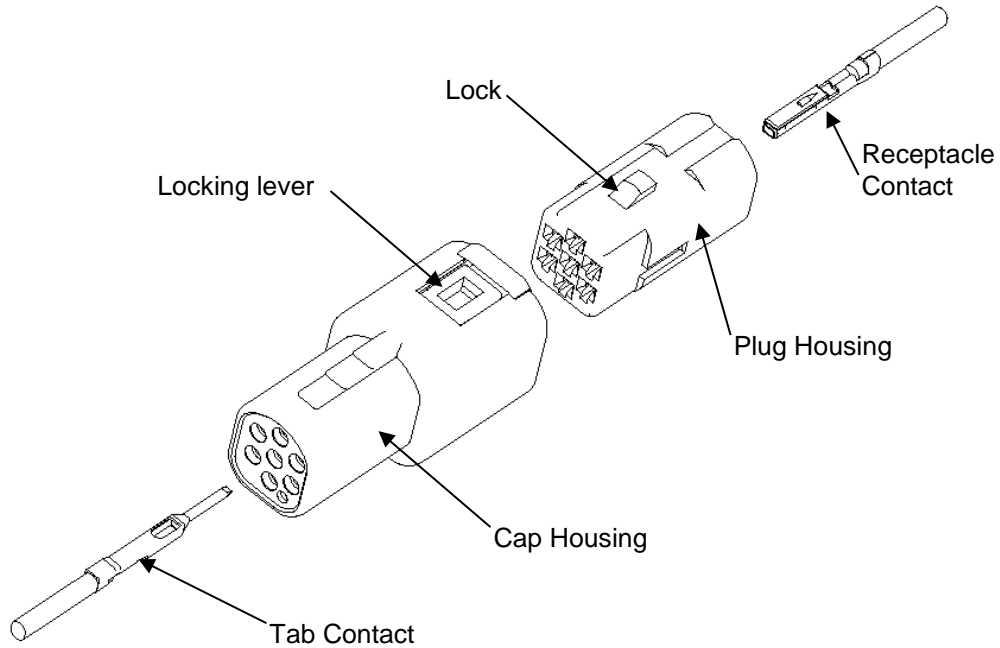
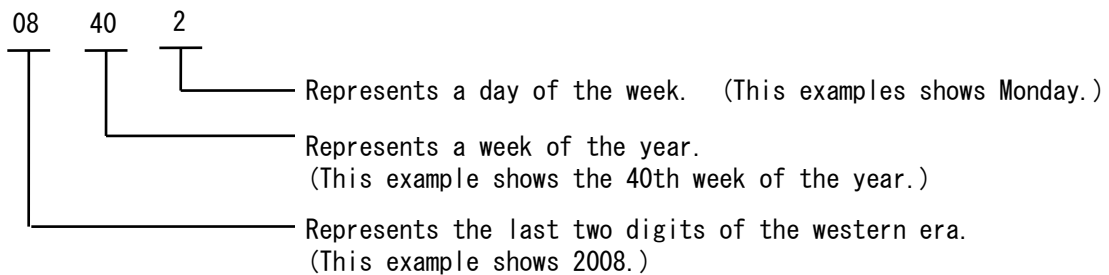

Fig.3

3. INSPECTING THE TABS, RECEPTACLES, AND HOUSINGS

3.1 Preshipment Inspections by TE

All the preshipment inspection by TE are carried out for each shipment lot based on the quality control rules and applicable standards by means of the statistical control method. As a general rule, the manufacturing date is shown on each of the packages in order to allow tracing of the manufacturing history by means of the comparisons with the inspection records, manufacturing records, and adjustment records for the machines and measurement instruments. Note that the manufacturing date is shown using a date code specified below.



3.2 Receiving Inspection by the Customer

It is recommended that the customer carry out his receiving inspection on the following points based on the customer drawing submitted by TE for his application.

«Tab and receptacle»

Item	Items to be inspected and inspection method	Measurement instrument to be used
External inspection	1)Profile	Visual
	2)Finish of the plating	Visual
	3)Winding condition	Visual
Size inspection	1)Wire barrel width and height	Caliper
	2)Width and height of insulation barrel	Caliper

Upon receipt of a given shipment lot, it is recommended to firstly inspect the entire lot visually to the level II (AQL 4%) of MIL-STD-105. Then, sort the reels based on the manufacturing date codes and take out the first five samples out of a given reel and inspect them to the same inspection criteria stated above. The shipment lot should be accepted when all the requirements stated above are satisfied.

«Housing»

Item	Items to be inspected and inspection method	Measurement instrument
Appearance	1)Burrs, discoloration, or deformation	Visual
	2)Crack, crevice, or tippin	Visual
Functional inspection	1)Fitting The housing shall be capable of smoothly mated with its mating housing without requiring an excessive force, and its lock shall be securely and positively engaged with its mating part. The housing shall be capable of smoothly disconnected from its mating housing when the leg to release the lock is operated.	Manual

#### 4. CRIMPING WORK

The tabs and receptacles shall be crimped using the tool specified by TE and following the procedures specified by the same. In addition, it is recommended to record the model number and date code ( 08402 stated as the example under the item 3.1 above.) of the crimped tabs and receptacles for the future reference.

##### 4.1 Storage and Transportation

- 1) Do not store or transport the tabs, receptacles, or housings with them at the condition as taken out of the container.
- 2) Do not lay the reel flat on the floor and carry it by holding it only on one side

Recommended method

Do not hold only one side by laying it

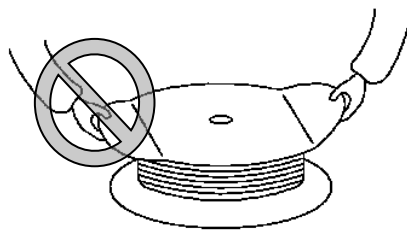

correct

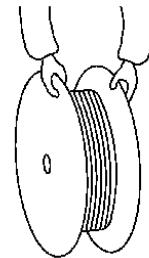
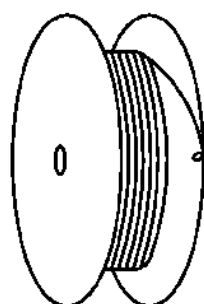

Fig.4

- 3) Do not leave the reel in a humid environment. Be sure to store it at a normal room ambient temperature and humidity in the dry and clean environment that is free from the direct sunlight. (The term “normal room ambient temperature and humidity” shall mean an ambient of 5 to 35 C and 45 to 85%, respectively.)
- 4) In case any reel is dismantled from the crimping machine due to some reason, it is recommended to tie the end of the tab to the reel using a thread so that it will not come loose.



Tie the end to prevent it from coming loose.

4.2 Control of the Crimping Work

It is necessary to control the crimping work by following the instructions stated in the separate documents as stated below.

Application Spec. 114-5193  
Automation instruction book

In particular, special attention needs to be paid to the following items.

- (1) Be sure to check that the wire is not damaged or trimmed off.

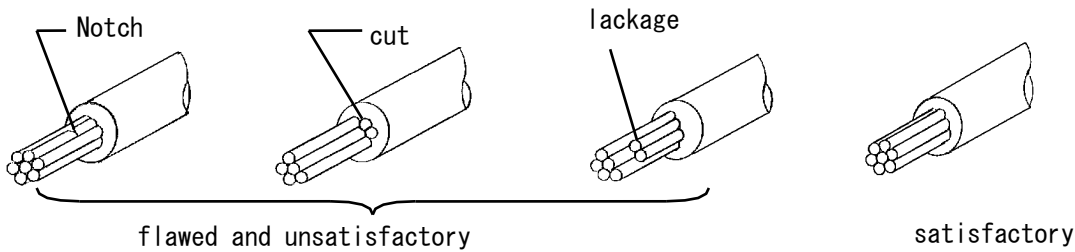
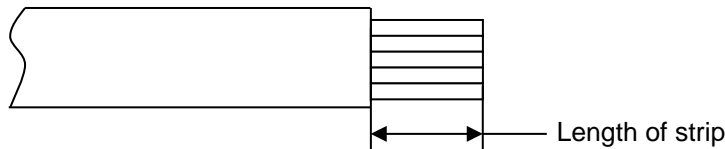

Fig.6

- (2) Way of terminal treatment during process



Length of strip length of barrel + (0.5 to 1.0)mm is appropriate.

Fig.7

- (3) Cross-section of crimp

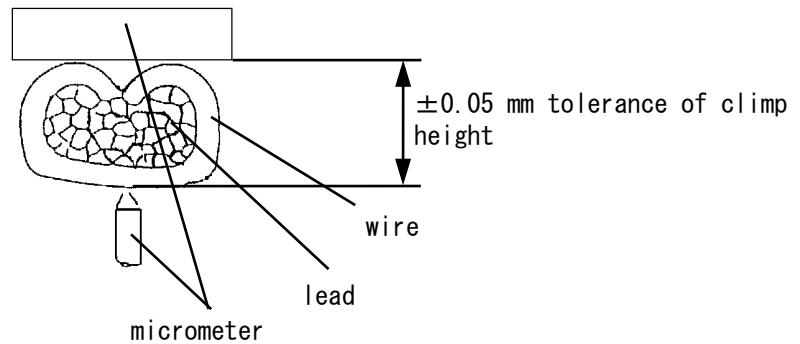

(Note)  
Tolerance of crimp height differs by terminal.

(4)Micrometer (for measuring crimp height)

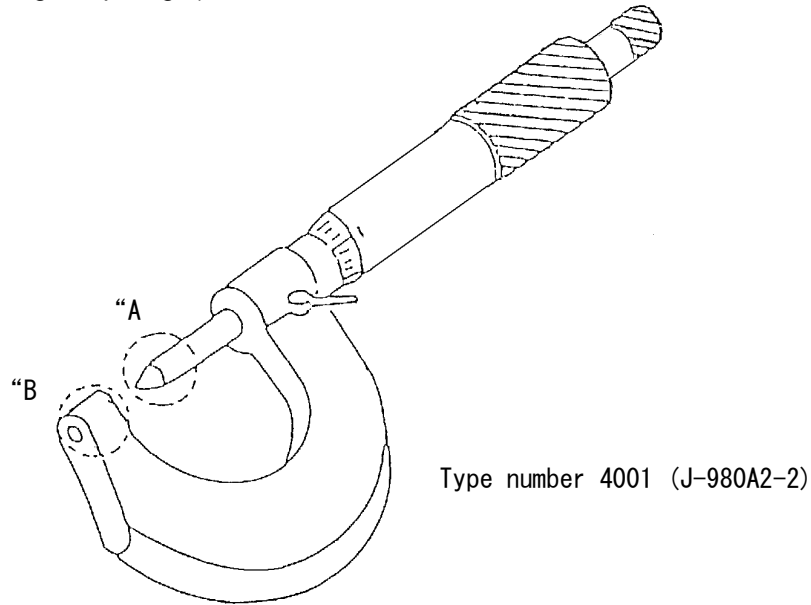
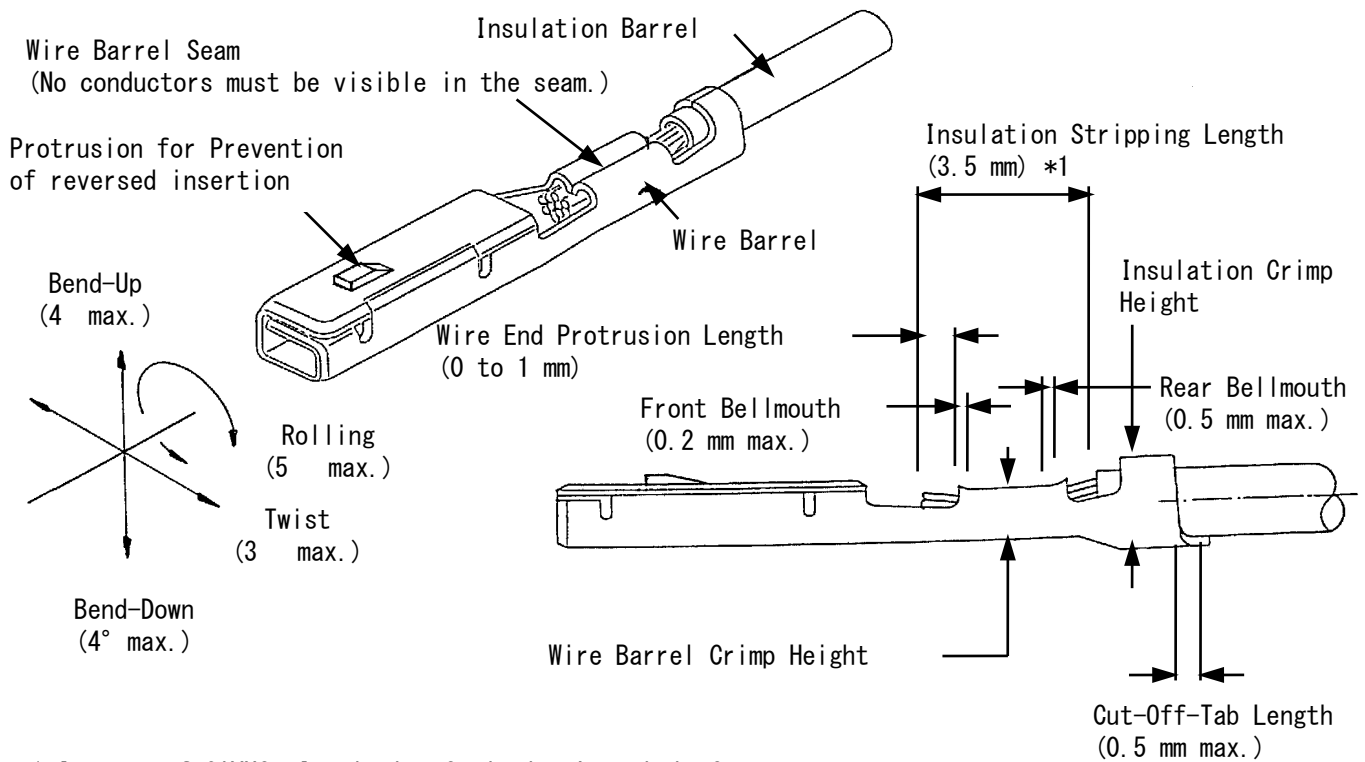

Fig.9

4.2.1 Crimped Condition of Contact :

(For detailed features, refer to Application Specification, 114-5193, Crimping of Mini-Multi-lock Connector contacts.)



\*1 In case of CAVUS, Insulation Stripping Length is 3 mm.

Fig.10

4.2.2 Crimp Data

Fig. 13 shows the detailed data of contact crimping by applicator. Confirm the contents before the operation.

Contact Part Number (Strip)	Wire Size (Nominal)	Applicator Number	Wire Barrel Crimp (mm)			Insulation Barrel Crimp (mm)			Crimp Tensile Strength (kg) (min.)
			Width	Height	Disc. Ltr.	Width	Height	Disc. Ltr.	
917308	0.3	715788-2	1.27	0.9	B	1.45	1.9	4	6
917309	0.5			1.02	A				9

4.2.3 Applicable Wires

Applicable Wires to be Automotive Low Voltage Wires (AVSS, CAVS 0.3 mm<sup>2</sup> to ~0.5 mm<sup>2</sup>)

Wire Size (Nominal)	No. of Conductors/ Diameter of a Conductor	Cross section Area of a Conductor (mm <sup>2</sup> )	AVSS / CAVS	
			Std.	Max.
0.3	7/0.26	0.37	1.4	1.5
0.5	7/0.32	0.56	1.6	1.7

4.3 Control of the Crimped Tabs and Receptacles

4.3.1 Inspection

It is recommended to carry out the inspection on the crimped tab under the identical conditions. For this purpose, it is recommended to inspect them for each manufacturing lot, which has been manufactured in one continuous crimping run before changing the settings of the crimping machine or in one day. The following table shows the guideline for the inspection.

Classification	Timing	Items to be inspected
Initial sample inspection	After setting the applicator to a given wire.	Appearance and dimension on all the items specified below.
Lot inspection	Before commencing the day's work.	Same as above
	During the continuous run.	Appearance on all the following items and dimensional inspections stated under the item 3 above.

Items	Specification for the inspection and method	Measurement instrument
Appearance	1.Omitted crimping or cut conductor	Visual
	2.Faulty crimping (Formation of the bell mouth or extruded conductor)	Visual
	3.Faulty crimping on the bottom (burrs)	Visual
	4.Dislocated shield holder	Visual
	5.Faulty profile on the contact	Visual
Dimensional inspection	1.Dimension of the cut off tab: 0.5 mm max.	Calipers
	2.Deformed tab (Vertical or horizontal bending, or twisting)	Magnifying glass
	3.Crimp height	Micrometer
	4.Bell mouth at front and rear of the crimped portion on the conductor,Front: 0.2 mm max.Rear: 0.5 mm max.	Calipers

4.3.2 Storage

- a) The wire harnesses after crimping the tab and receptacle should be stored in a dry and clean ambient. Further, they should not be stored under exposed condition, if they are to be stored for a prolonged period of time.
- b) A maximum of 100 wire harnesses should be bundled together.
- c) Protruded portion of the tab may be caught each other if many of them are simply stuck. Or, such a stacking may result in deforming the tab due to its dead weight, which in turn could cause problems such as the continuity failure.
- d) Be sure to carefully handle the wire harness assemblies when separating them from the bundle since the tab and receptacle may have been caught each other. Failure to observe the instruction will result in deformed tab.
- e) Do not store the tabs or receptacles not crimped in a humid ambient. Be sure to store it at a normal room ambient temperature and humidity in the dry and clean environment that is free from the direct sunlight. (The term “normal room ambient temperature and humidity” shall mean an ambient of 5 to 35°C and 45 to 85%, respectively.)
- f) Attention should be paid not to allow the tab to catch each other or to be deformed when they are to be stored or transported after crimping. (A maximum of 100 wires should be bundled.)



5. MANUFACTURING HARNESS ASSEMBLIES

5.1 Storage and Handling

- (1) Avoid carrying unpacked products. Carry and store products in the containers.
- (2) Do not place reels in places with high humidity. Reels should be stored in a relatively dry, clean room where they will not be exposed to direct sunlight and maintained at normal temperature and humidity. (5 to 35°C and 4 to 85% relative humidity)

5.2 Orientation of Receptacle Contacts when-Loading into Housing Cavities :

5.2.1 Plug Housing (P/N 2822343):

Hold the plug housing with its locking device side facing upward, insert receptacle contact into housing cavities, with the receptacle contacts held with its contacting end first, and the flat upper surface of contact box portion facing upward, as far as it goes into the cavity and lock in the position.

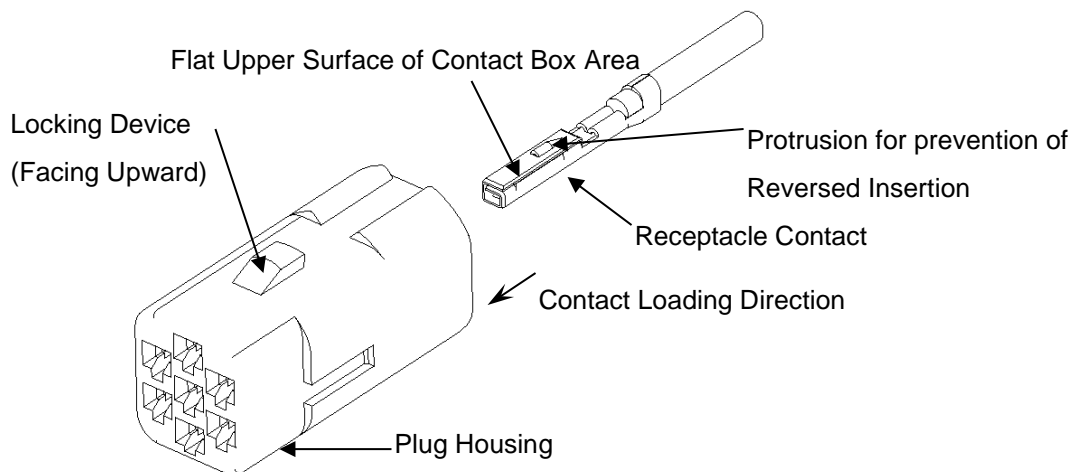

Fig.11

5.2.2 Loading Receptacle Contacts into Cavities of Plug Housing

After confirming the orientation of contact by referring to Para. 5.1.1, insert the contact into the designated hole of the housing, until it goes to the bottom and to get engaged with the locking device, when a small clicking sound is heard at engagement of locking. Contact must be inserted with its barrel seam side facing upward. When the contact is locked, just pull back the crimped wire lightly, to make sure the condition of locking, as the contact stays in place of locking. Plug housing must be kept with its locking device facing upward. At insertion of contacts into housing, the sequence of the holes into which the contacts are inserted, must be in accordance with the figures as shown in the left side depiction of Fig. 12 below. In which, you insert in the sequence of No. 1, 2 and so on, if to insert into positions Nos. 2, 3, 5 and 7 first, the contacts of the upper cavities will be not allowed to enter and to get locked in position. Follow strictly the sequence of the numbers.

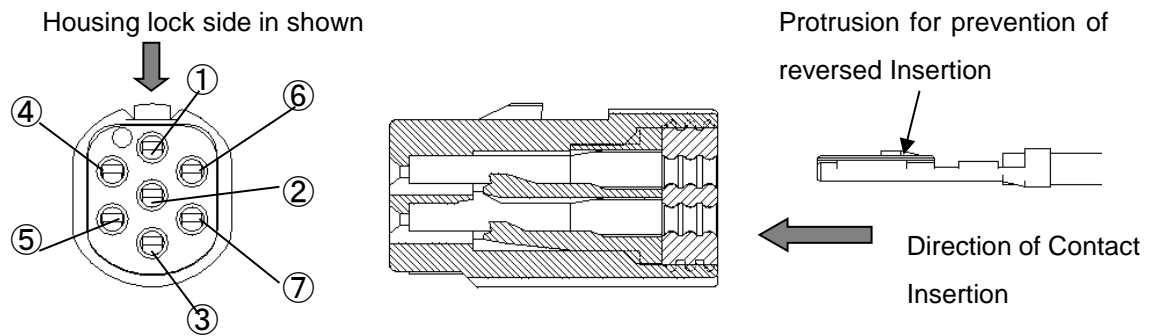

Fig.12

5.3 Orientation of Tab Contacts when Loading into Housing Cavities :

5.3.1 Cap Housing (P/N 2822344)

Hold the cap housing with its locking device facing downward, insert tab contact into housing cavities, with the tab contact held with its contacting end first and the flat upper surface of contact box portion facing upward, as far as it goes into the cavity and lock in the position.

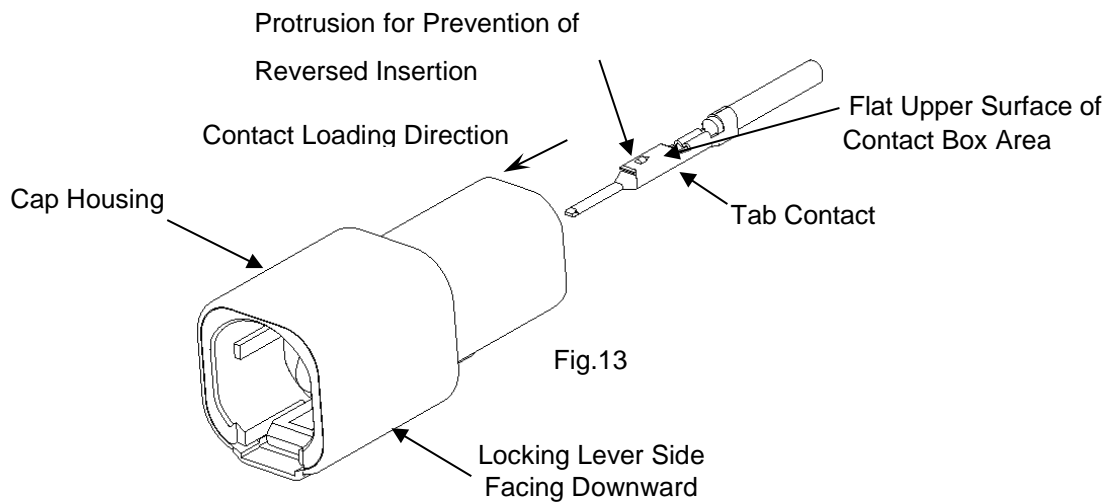
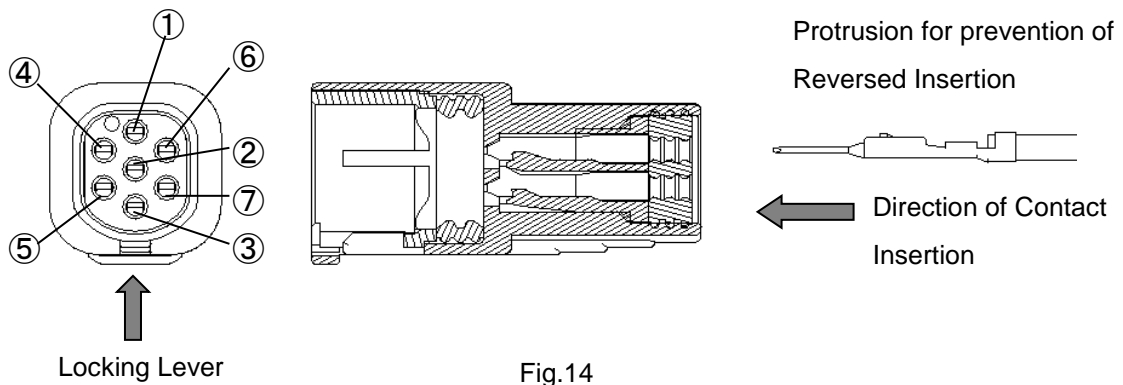

Fig.13

5.3.2 Loading Tab Contacts into Cavities of Cap Housing :

After confirming the orientation of contact by referring to Para. 5.2.1, insert the contact into the designated hole of the housing, until it goes to the bottom and to get engaged with the locking device, when a small clicking sound is heard at the engagement of locking. Contact must be inserted with its barrel seam side facing upward. When the contact is locked, just pull back the crimped wire lightly to make sure the condition of locking, as the contact stays in place of locking. Plug housing must be kept with its locking device facing downward. At insertion of contacts into housing, the sequence of the holes into which the contacts are inserted, must be in accordance with the figures as shown in the left side depiction of Fig. 14 below, in which you insert in the sequence of Nos. 1, 2, 3, 4 and so on, if not with this sequence such as into the positions Nos. 4, 5, 6 and 7 first, the contacts of the upper cavities will be not allowed to enter and to get locked in position. Follow strictly the sequence of the numbers.



5.4 Mounting of the Tab and Receptacle into the Waterproof Housing

5.4.1 Orientation of the tab in the rubber plug and precautions there of When inserting the tab into the rubber plug mounted inside the cap housing in advance, confirm that the locking lever is facing downward, and the orientation dimple provided on the rubber plug is facing upward. Then, insert the tab into the hole provided in the rubber plug while facing the top surface of the tab (seam side) upward direction. With the plug housing, confirm that the lock and orientation dimple of the rubber plug are facing upward, then, insert the tab into the hole provided in the rubber plug.

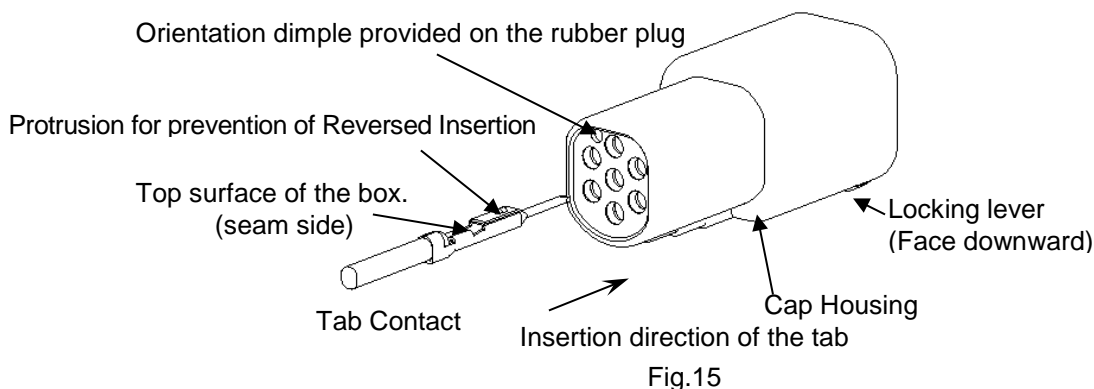

In case of plug housing, confirm that the locking device and the operation dimple provided on the rubber plug are facing upwards, then insert the contact into the hole of rubber.

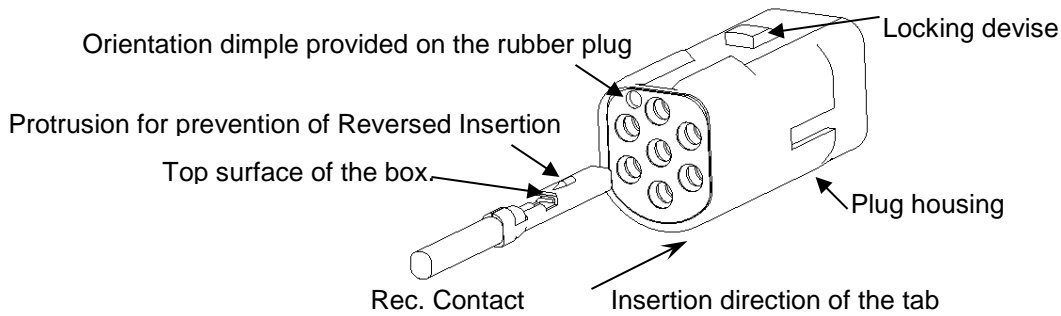

Fig.16

#### 5.4.2 Insertion of the contact into the housing

When inserting the contact into the housing, be sure to confirm its orientation stated under the item 5.3.1 above. Note that the contact should be inserted in sequence starting from the position ① as stated under the items 5.1.2 and 5.2.2. Do not apply excessive force to the contact when inserting it since it may result in damaging the rubber plug, which will reduce its waterproof performance.

##### 1) Contact check and incomplete engagement

Confirm that a click sound is heard when the contact is inserted into the housing. In addition, lightly pull the wire so that it will not come out. The contact is not properly engaged in the housing if the contact comes out of it. In this case, insert it by following the procedures stated under the item 5.3.2.

##### 2) Confirmation of reverse insertion

It will not be possible to insert the contact all the way to the proper mouting position if it is inserted upside down since the dimple provided on the contact interferes with the lance provided in the rubber plug (see the figure shown below). The contact will come out of the rubber plug if it is pulled. Check the contact orientation once again before inserting it once again.

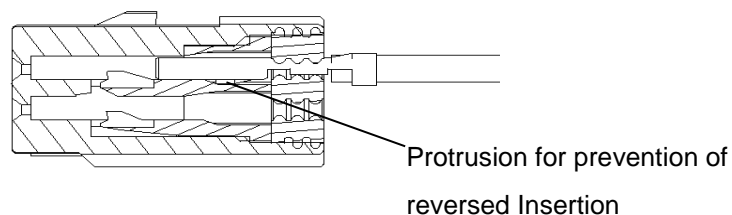

Fig.17

5.5 Insertion of the Dummy Plug

Insert a dummy plug in each of the holes, if it is not to be used.

Work sequence

- (1) Insert the dummy plug into the rubber plug.

Hold the plate and insert the dummy plug until its rear end comes out of the rubber plug.

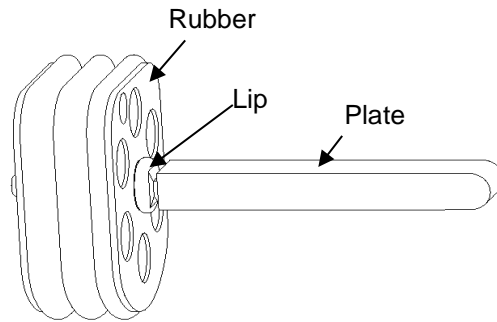

Fig.18

- (2) Snap off the plate.

Pay attention not to allow the plate to migrate into the products.

Confirm that the rear end lip of the dummy plug (yellow) is now visible.

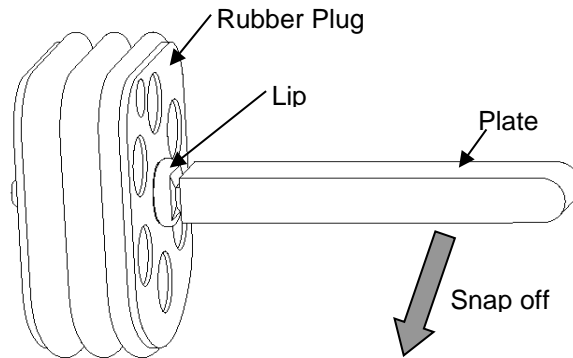

Fig.19

6. HOW TO DISMOUNT THE TAB

6.1 Precautions Upon Dismounting the Tab

This product is structurally difficult to dismount the tab or it will not be possible to dismount the tab only with a part of area. Be aware of the following note to dismount the tab.

- (1) Not be possible to dismount the tab from ①
- (2) In case of mounting the tab into ①, be sure not to dismount the tab from ④
- (3) In case of mounting the tab into ① and ④, be sure not to dismount the tab from ⑦

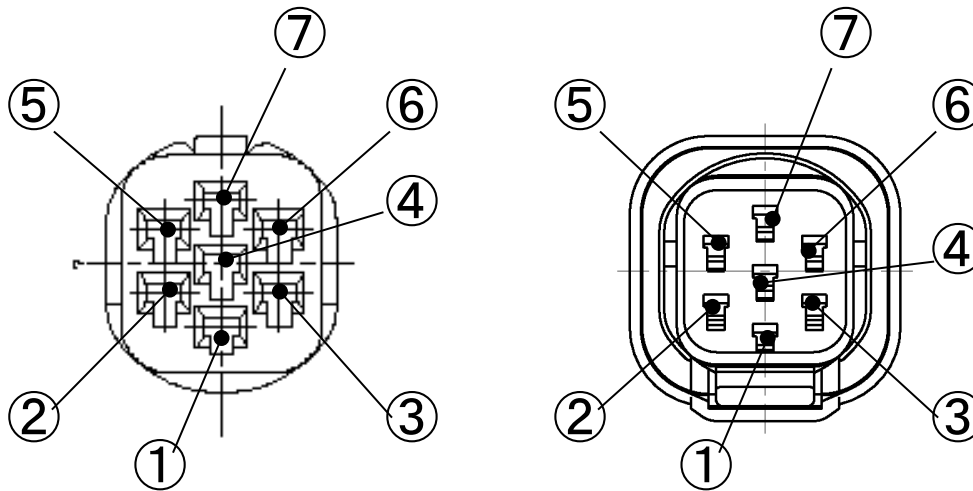

① In case of dismantling the tab into ①, be sure to dismantle the tab starting from the position ②

(Note that dismantling order is opposite from that of mounting)

Note: It will not be possible to dismantle the tab in other sequence.

### 6.2 Dismounting the tab work (Non-waterproof)

(A) Hold the wire of the tab that needs to be dismantled, push it into the housing, and hold it as is.

(B) Insert the dismantling tool or special tool into the housing from the other side until its tip contacts with the housing lance wall.

Note: Do not insert the tool into the contact.

(C) Confirm that the tool tip is in contact with the housing lance, then push it down.

(D) Dismount the tab holding down the housing lance.

### 6.3 Dismounting the tab work (Waterproof)

When dismantling the tab from the waterproof housing, follow the steps described under the items 6.2 . Pull out the wire by approximately 3.0 mm while pressing down the housing lance. Proceed to the next contact until all the contacts are set to the same position. Then, hold all the wires and pull them to dismantle the tabs or receptacles.

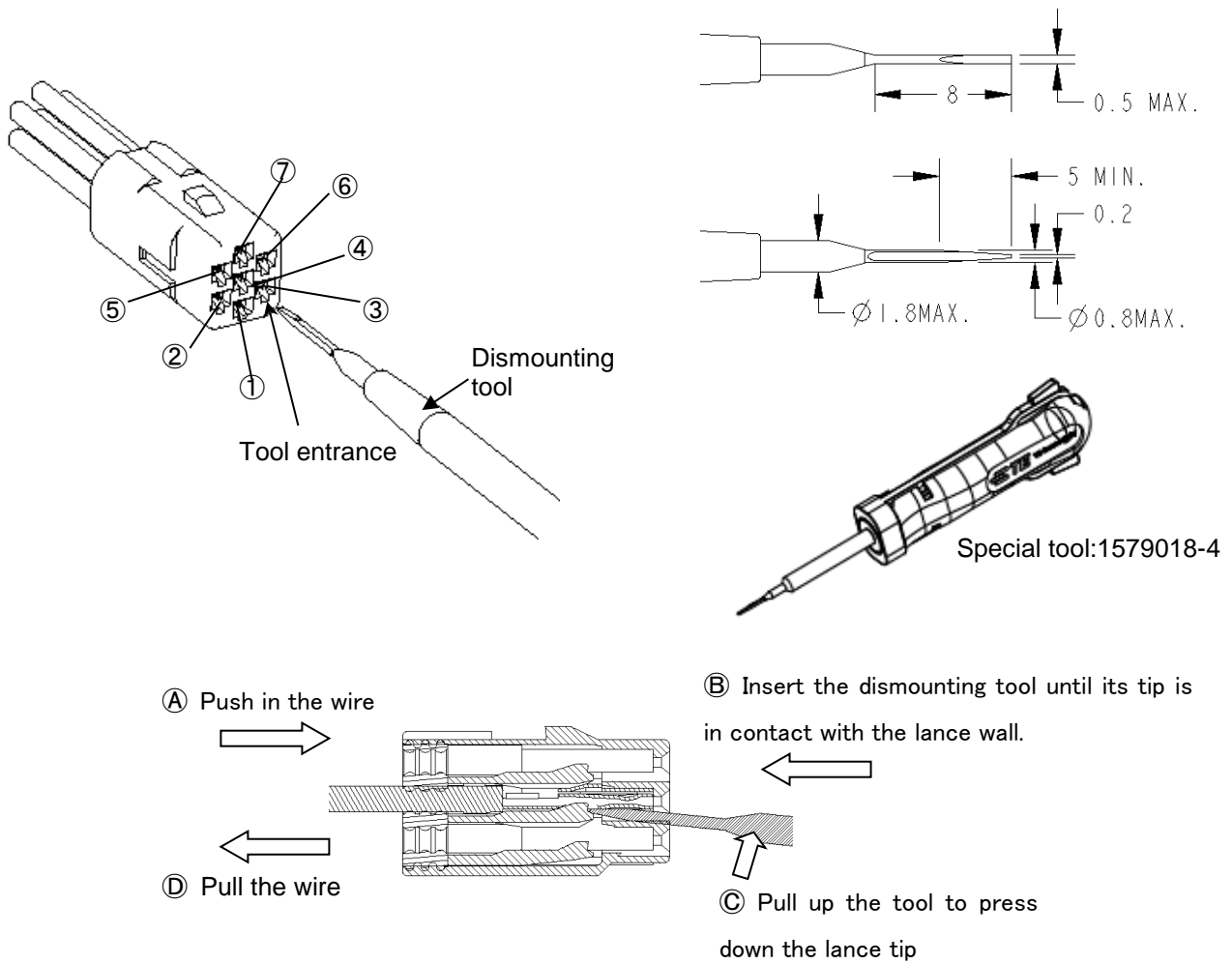

Fig.20

Note:

- ① Don't reuse the housing, when dismounting the contact. The performance decreases by deformation of housing, lance, and the area of mounting.
- ② When reuse the contact, check the variety and crack of contact. If you find them, do not use the contact.

7. MATING AND UNMATING THE HOUSINGS

7.1 Mating Work of the Housings

Orient the locking lever and lock in the same direction and mount the housings by moving the two along the same axis. (Refer to 7.2 how to confirm the proper mating.)

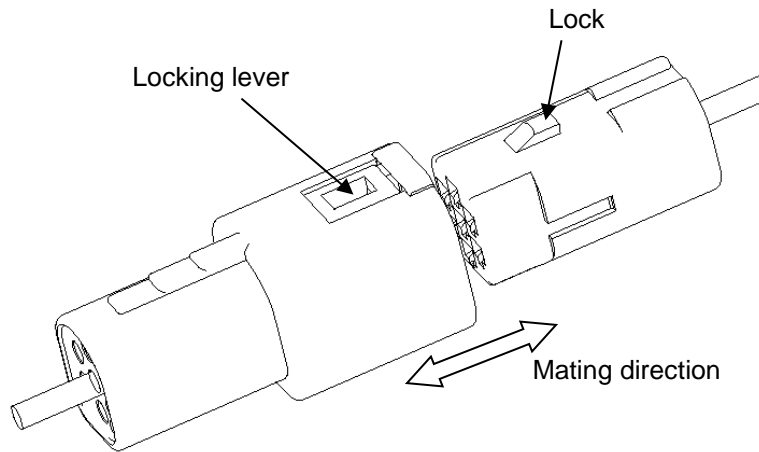

7.2 Incomplete Mating

The following figure shows incompletely mated housings. Do not leave the housings if they are incompletely mated. The housings are incompletely mated if the locking lever is left floating. No click sound can be heard if the locking lever remains floating. Press the housings once again until they are completely mated. The click sound will be heard when the locking mechanism has functioned. Further, pull the housings toward front in order to confirm that they have been securely locked.

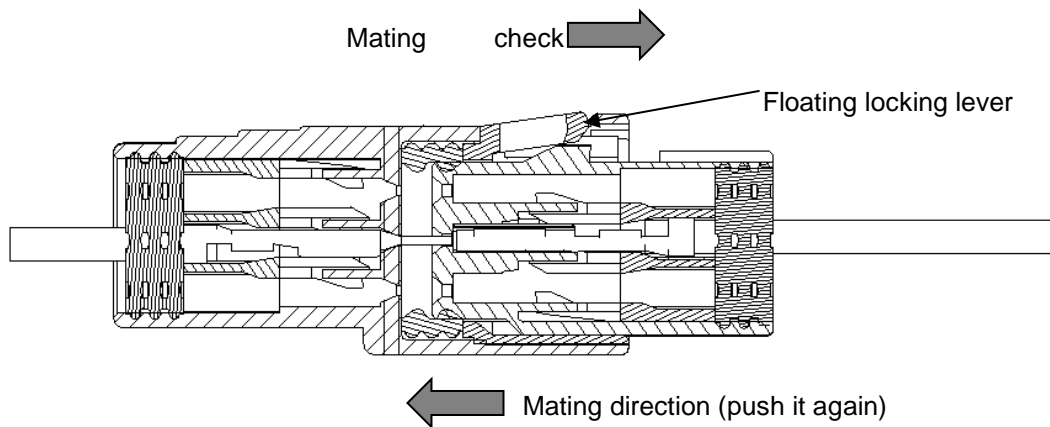

Fig.22



7.3 Completion of the Mating Work and Unmating Work of the Housings

a) A click sound is heard when the housings are properly mated and the locking mechanism has functioned. Lightly pull the housings toward front in order to confirm that they have been securely locked. If it is necessary to unmate the housings, insert the precision screwdriver or special tool beneath the locking lever as shown in the figure below, then, pull the housings toward opposite directions while pressing down the tip of the screwdriver.

Note that the wires should not be held to unmate the housings.

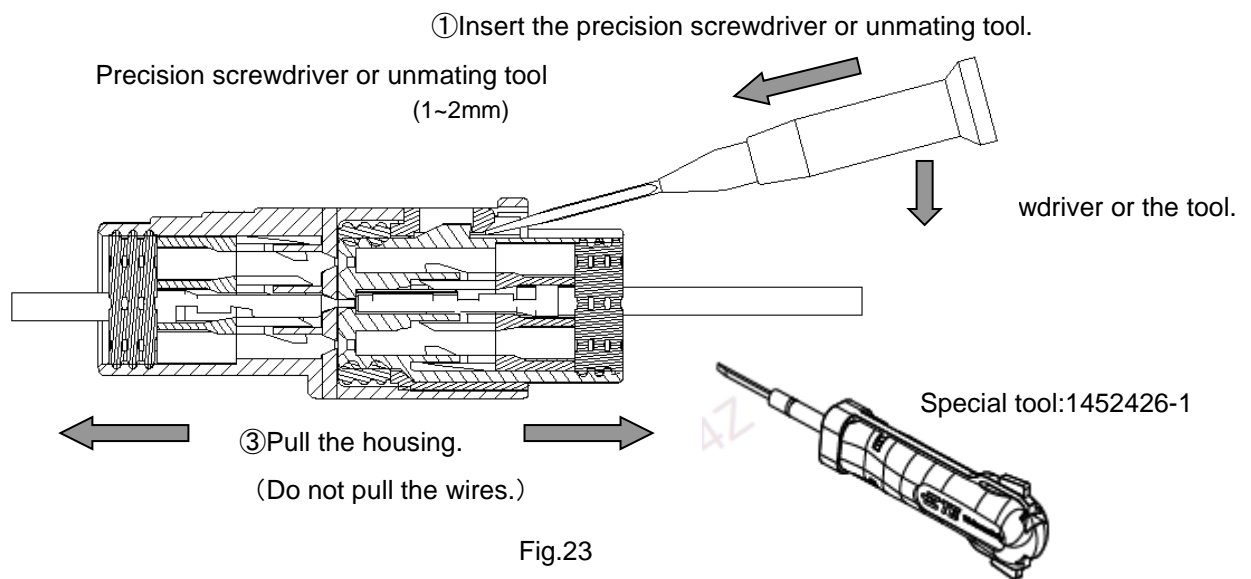

8. CONTROLLING THE WIRE HARNESSSES

8.1 Inspection

It has been requested that all the completed wire harnesses is to be inspected, for which the following items are mandatory.

- a. Do not use the mating tab or equivalent as the probe to check the entire housing circuit.
- b. It is strictly forbidden to directly insert the inspection probe into the contact since it may deform the contact. Accordingly, the inspection probe should be inserted into the housing from the wire side, if necessary.

8.2 Storage

a) The wire harnesses shall be stored in a dry and clean environment. In addition, they should not be left exposed if they are to be used on the next day.

8.3 Shipping and Transportation

- a) It is necessary to carefully handle the wire harnesses using a proper container to avoid possible contamination by the dust or rain water.
- b) It is necessary to clearly mark the applicable standards.

## 9. MOUNTING ON THE VEHICLE

### 9.1 Receiving Inspection

The following items should be inspected.

- a) Bundled position of the wire harness that is extending from the housing. (A minimum of 30 mm.)
- b) Mounted condition of the tab in the housing.
- c) Surface finish of the tab such as the eminent discoloration, flaw, or deformation.
- d) Cracked, defective, or discolored housing.
- e) Check on the defective parts.

### 9.2 Control Points for the Mounting Work

- a) The housings need to be mated on the same axis, and it is necessary to confirm that the locking mechanism has been positively functioned. A click sound can be heard if the housings are locked. Lightly pull the housings after mating them to confirm the locking. No click sound is heard if the housings are incompletely mated.
- b) Do not repeat unwanted mating and unmating operations of the housings.
- c) Be sure to use the specified dismounting tool and follow the procedures stated under the item 6 if it is necessary to dismount the tab from the housing due to some reason.
- d) Be sure to use the mating tab or equivalent if the circuit needs to be checked.
- e) Attention should be paid when handling the wire harness to avoid the followings.
  - 1) Rough handling such as to throw out the wire harnesses.
  - 2) Handling that may allow the wire harnesses to contact the floor.
  - 3) To carry the wire harnesses while holding the housings.
  - 4) Handling that results in applying excessive force to the housings.
- f) Follow the procedures stated under the item 7.3 if it is necessary to unmate the housings.

9.3 Precautions Upon Taping the Wire Harness End

The following precaution should be kept in mind when taping the wire harness. An excessive force may be applied to the tab inside the housing if the wires coming out of the housing are bundled or bent by 90 degrees immediately at the wire exit, which in turn may result in faulty mating of the housings. Accordingly, the wires should be bundled or bent at the position which is distant from the exit. (30mm Min.)

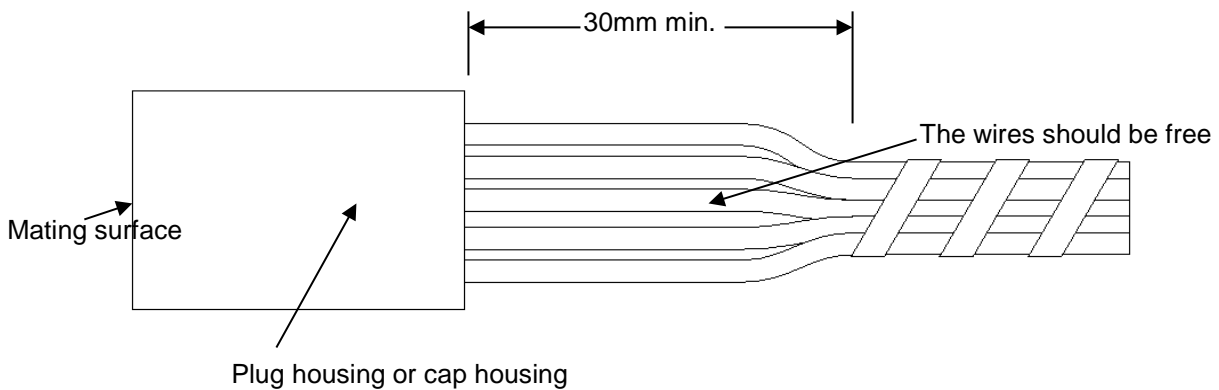

Fig.24

9.4 Specifications for the Harness Checker

Use the spring probe as the harness checker. Be sure to set the pressing force to the contact at a maximum of 9.8N.

9.4.1 How to check the receptacle contact

Check the receptacle contact as shown in the following figure; Insert the probe from the mating surface of the plug housing until it is in contact with the bottom end of the contact. Be sure not to apply an excessive force (9.8N or greater) at this time since it may deform the contact end. Never try to insert the probe directly into the contact since the contact reliability will be reduced.

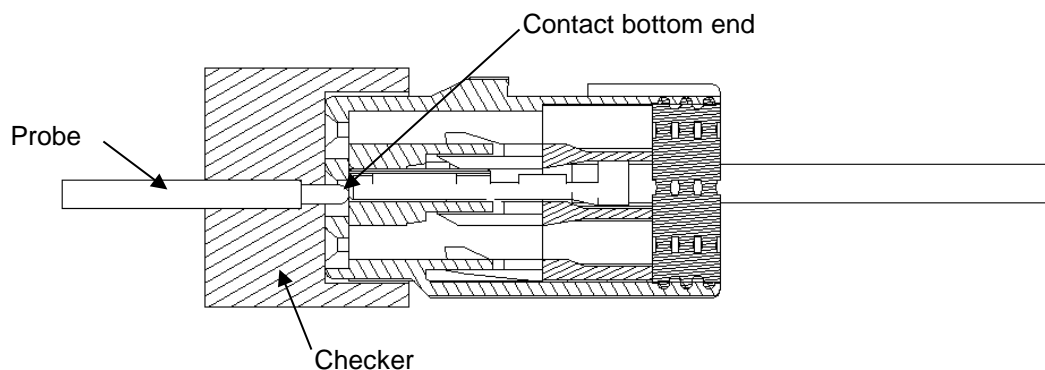

Fig.25

9.4.2 How to check the tab contact

Check the tab contact as shown in the following figure; Insert the probe from the mating surface of the cap housing until it is in contact with the end of the tab contact. Be sure not to apply an excessive force (9.8N or greater) at this time since it may deform the tab end.

9.4.3 Recommended probe dimensions

Use a probe that has the end diameter of 0.8 mm and stroke of 3 mm maximum.

