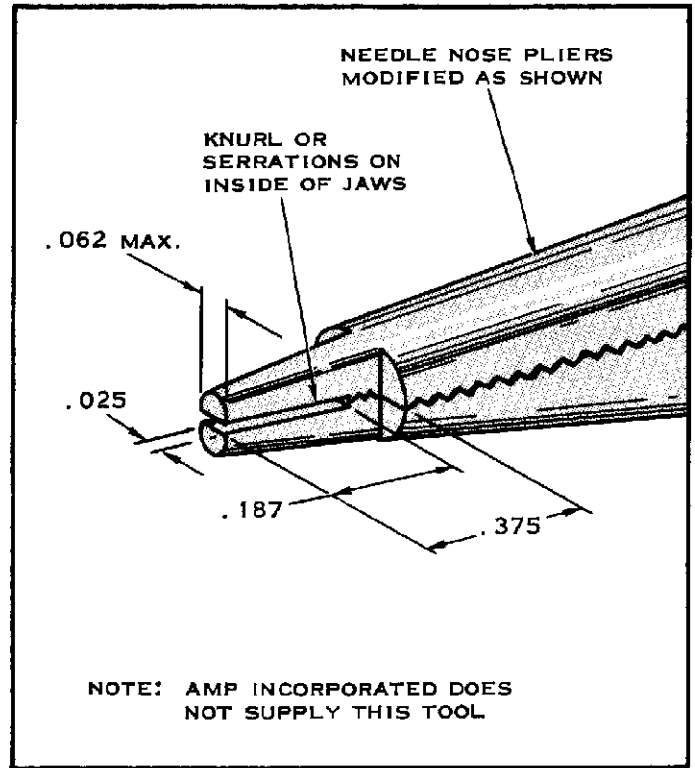

FIGURE 1



NOTE: AMP INCORPORATED DOES NOT SUPPLY THIS TOOL

FIGURE 2

The On-Contact Keying Plug is inserted into the slot normally occupied by a Contact of any Modified Fork Connector, Figure 1.

1. Grip the Keying Plug with a pair of Needle-nosed Pliers (Figure 2), the Keying Plug Bottom pointed toward the Connector.
2. Insert the Keying Plug into the front of the Connector's Terminal Slot as far as it will go.
3. To remove the Keying Plug, use the same Pliers. Simply pull the Keying Plug out of the Connector.
4. Cut a slot in the mating Printed Circuit Board to accept the Keying Plug. Figure 3.

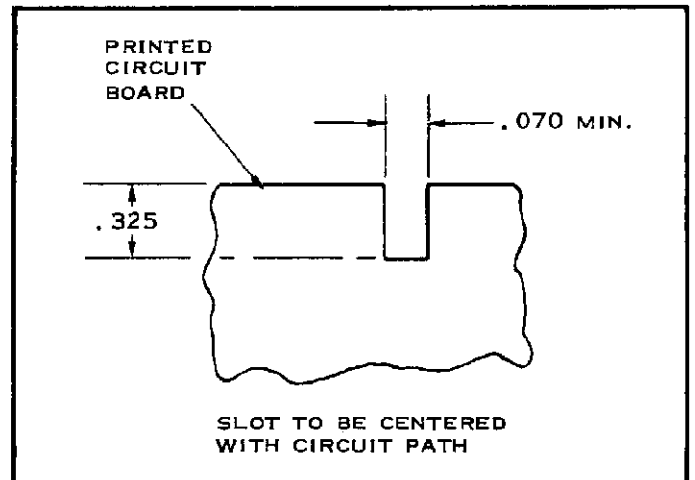

SLOT TO BE CENTERED WITH CIRCUIT PATH

FIGURE 3

© 1967 by AMP Incorporated. All international rights reserved. A-M-P®
 Products covered by U. S. and foreign patents and/or patents pending.