

AMP

AMP INCORPORATED
HARRISBURG, PA 17105

APPLICATION AND MAINTENANCE FOR AMP* HAND CRIMPING

IS 7156

CUSTOMER HOTLINE
1 800 722-1111

TOOL 90119-1

RELEASED
6-28-88

Section I of this instruction sheet provides application procedures for AMP hand crimping tools.

Section II provides maintenance and inspection procedures for AMP hand crimping tools.

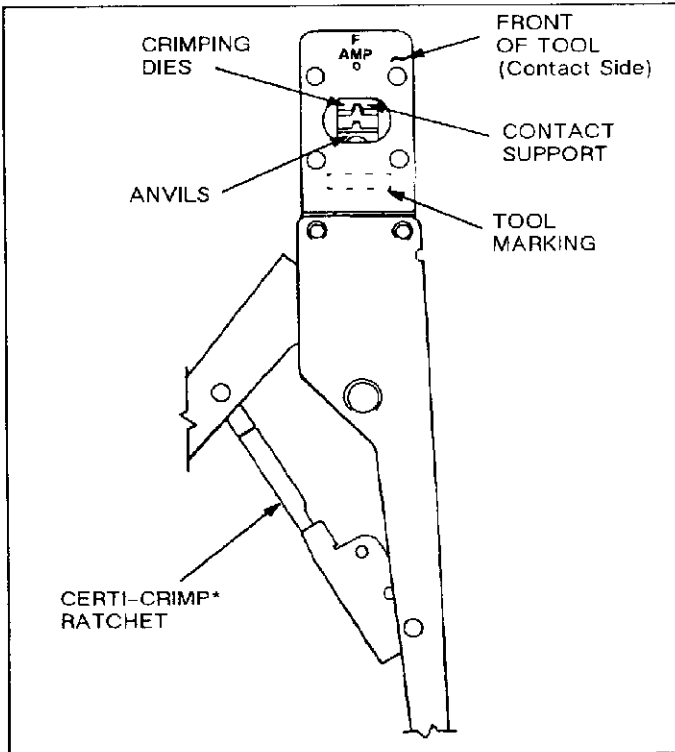

Fig. I-1

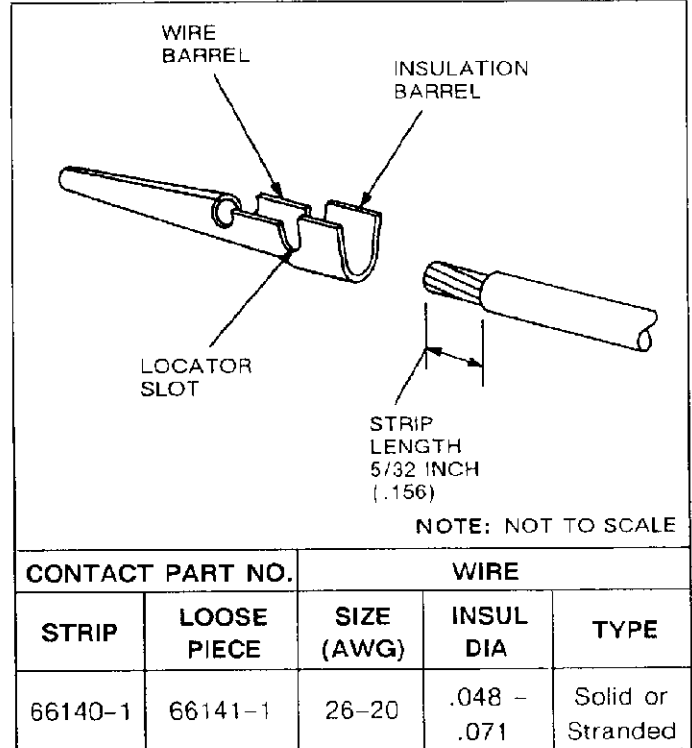

Fig. I-2

SECTION I APPLICATION

I-1. INTRODUCTION (Figures I-1 and I-2)

AMP Hand Crimping Tool 90119-1 (Figure I-1) is designed for crimping loose-piece Taper Pin contacts listed in Figure I-2. Read these instructions thoroughly before starting.

NOTE

All dimensions on this instruction sheet are in inches.

I-2. DESCRIPTION (Figures I-1, I-2, and I-3)

The FRONT of the tool (contact side), into which the contact is inserted, has the tool number marked on it. The BACK of tool (wire side), into which the wire is inserted, has the Crimp Symbol marked above the crimp section.

CAUTION

The crimping dies bottom before the CERTI-CRIMP ratchet releases. This is a design feature that assures maximum electrical and tensile performance of the crimp. Do NOT re-adjust the ratchet.

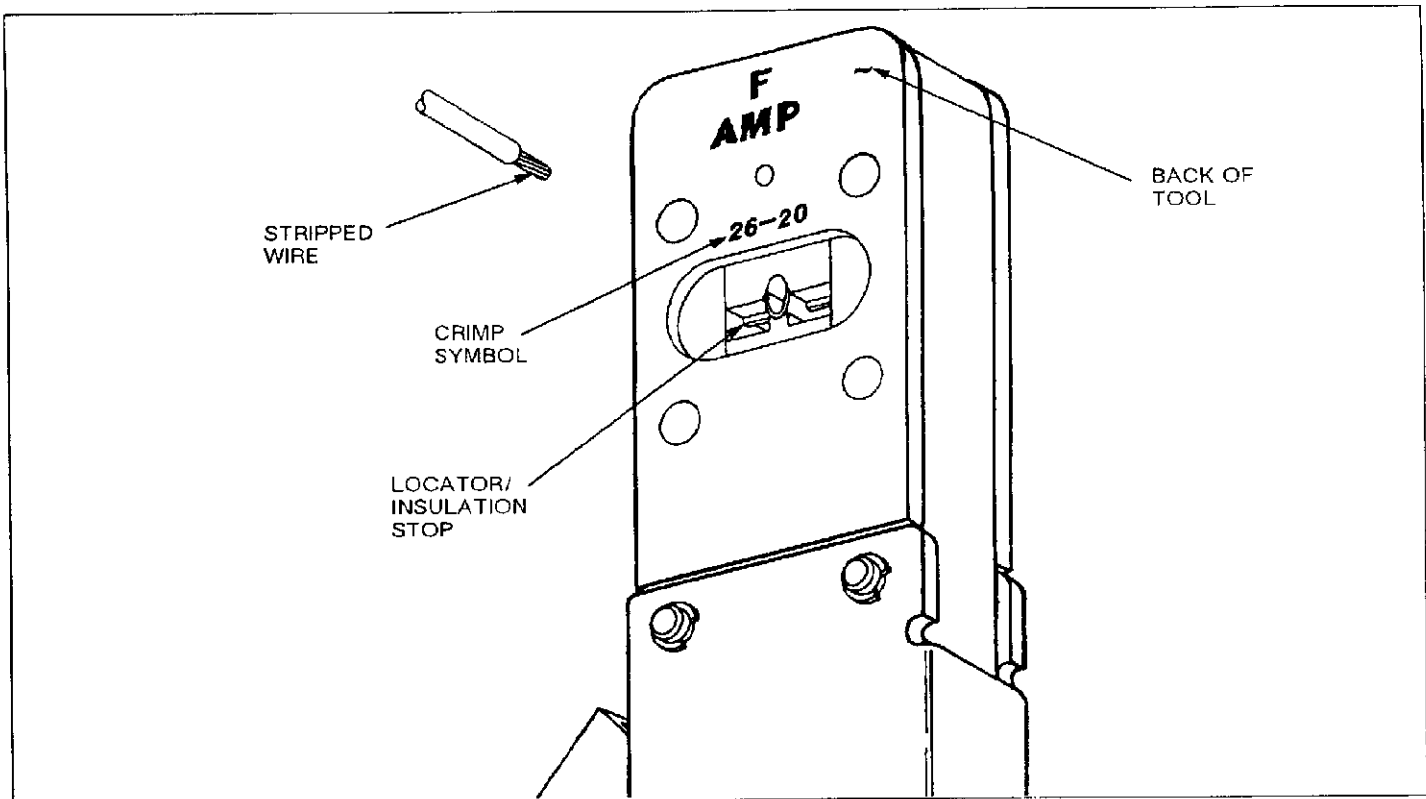

Fig. I-3

I-3. CRIMPING PROCEDURE

Refer to the chart in Figure I-2 and ensure that the wire of the specified size and insulation diameter is compatible with the contact. Strip the wire to the length indicated — do NOT cut or nick the wire strands. Proceed as follows:

1. Hold tool so BACK side (wire side) faces you. See Figure I-3.
2. Ensure that tool ratchet is released by squeezing tool handles and allowing them to open FULLY.
3. Looking straight into BACK of the crimp section, insert contact, (insulation barrel first) into FRONT of crimp section. Position contact between crimpers so locator/insulation stop enters locator slot in contact. The wire barrel should butt against the locator/insulation stop.
4. Holding contact in this position, squeeze tool handles together until insulation barrel anvil starts entry into insulation crimper. Do NOT deform insulation barrel or wire barrel.

5. Insert a properly stripped wire into wire barrel of contact until insulation butts against the locator/insulation stop.

6. Holding wire in place, crimp contact to wire by squeezing tool handles together until ratchet releases.

7. Allow tool handles to open FULLY so ejector can push contact out of crimpers. Remove crimped contact from tool.

I-4. DAILY MAINTENANCE

Remove all foreign particles with a clean, soft brush, or a clean, soft, lint-free cloth. Make sure the proper retaining pins are in place, and secured with the proper retaining rings. If foreign matter cannot be removed easily, return the tool to your supervisor.

Make certain all pivot points and bearing surfaces are protected with a THIN coat of any good SAE No. 20 motor oil. Do NOT oil excessively. When tool is not in use, keep the handles closed to prevent objects from becoming lodged between the crimping dies, and store the tool in a clean, dry area.

Section I of this instruction sheet provides application procedures for AMP hand crimping tools.

Section II provides maintenance and inspection procedures for AMP hand crimping tools.

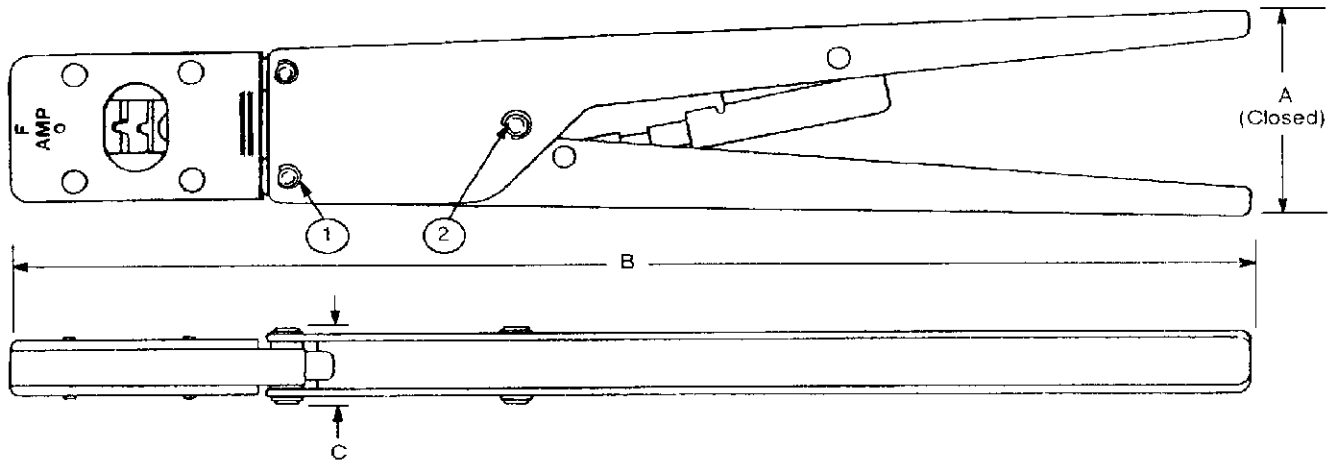

TOOL SPECIFICATIONS		CUSTOMER-REPLACEABLE PARTS			
DIMENSION	WEIGHT	ITEM	PART NUMBER	DESCRIPTION	QTY
A 2 1/2	1 lb 4 oz	1	21045-3	RING, Retaining	4
B 11 7/8		2	21045-9	RING, Retaining	2
C 3/4					

CAUTION DO NOT REMOVE THE RETAINING PINS AS PERMANENT DAMAGE TO THE TOOL COULD RESULT (See Paragraph II-2).

Fig. II-1

SECTION II MAINTENANCE/INSPECTION

These instructions have been approved by AMP Design, Production, and Quality Control Engineers to provide documented maintenance and inspection procedures in accordance with AMP Corporate Policy No. 3-3. Through AMP test laboratories and the inspection of production assembly, the procedures described herein have been established to ensure quality and reliability of AMP hand crimping tools.

Customer-replaceable parts are listed in Figure II-1. A complete inventory should be stocked and controlled to prevent lost time when replacement of parts is necessary. When parts are needed, order by part number and description.

II-1. INSPECTION PROCEDURES

A. Daily Maintenance

It is recommended that each operator of the tool be made aware of — and responsible for — the following four steps of daily maintenance:

1. Remove dust, moisture, and other contaminants with a clean brush or a soft, lint-free cloth. Do NOT use objects that could damage the tool.

2. Make sure the proper retaining pins are in place and secured with the proper retaining rings.
3. Make certain all pins, pivot points, and bearing surfaces are protected with a THIN coat of any good SAE No. 20 motor oil.
4. When the tool is not in use, keep the handles closed to prevent objects from being lodged in the crimping dies and store the tool in a clean, dry area.

B. Periodic Inspection

Regular inspections should be performed by quality control personnel. A record of scheduled inspections should remain with the tool and/or be supplied to supervisory personnel responsible for the tool. Though recommendations call for at least one inspection a month, the inspection frequency should be based on the amount of use, ambient working conditions, operator training and skill, and established company standards. These inspections should be performed in the following sequence:

B-1. Visual Inspection

1. Remove all lubrication and accumulated film by immersing the tool (handles partially closed) in a suitable commercial degreaser that will not affect paint or plastic material.

2. Make certain all retaining pins are in place and secured with retaining rings. If replacements are necessary, refer to parts listed in Figure II-1.
3. Close the tool handles until the ratchet releases, then allow tool handles to open freely. If they do not open quickly and fully, the spring is defective and must be replaced (see Paragraph II-2, REPAIR).
4. Inspect the head assembly, with special emphasis on checking for worn, cracked, or broken dies. If damage to any part of the head assembly is evident, return the tool to AMP for evaluation and repair (see Paragraph II-2, REPAIR).

B-2. Crimp Height Inspection

This inspection requires the use of a micrometer with a modified anvil as shown in Figure II-2. We recommend the modified micrometer (Crimp Height Comparator RS-1019-5L) which can be purchased from:

York Machinery & Supply Co. VALCO
 20 North Penn Street or 1410 Stonewood Drive
 York, PA 17401-1014 Bethlehem, PA 18017-3527

Proceed as follows:

1. Refer to the chart in Figure II-2, and use the maximum size wire for the contact listed in the chart.
2. Refer to Paragraph I-3, CRIMPING PROCEDURE, and crimp the contact(s) accordingly.
3. Using a crimp height comparator, measure wire barrel crimp height as shown in Figure II-2. If the crimp height conforms to that shown in the chart, the tool is considered dimensionally correct. If not, return the tool to AMP for evaluation and repair (see Paragraph II-2, REPAIR).

For additional information concerning the use of the crimp height comparator, refer to AMP Instruction Sheet IS 7424.

B-3. CERTI-CRIMP Ratchet Inspection

Obtain a .001-in. shim that is suitable for checking the clearance between the bottoming surfaces of the crimping dies.

Proceed as follows:

1. Select a contact, wire (maximum size), and the designated crimp section for the contact you are using (see Figure II-2).

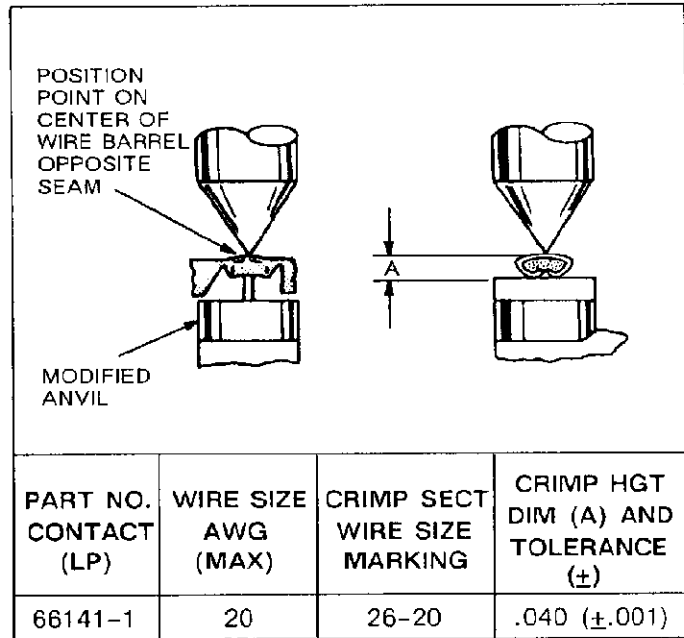

Fig. II-2

2. Position the contact and wire between the crimping dies, according to Paragraph I-3, CRIMPING PROCEDURE. Holding the wire in place, squeeze the tool handles together until the CERTI-CRIMP ratchet releases. Hold the tool handles in this position, maintaining just enough pressure to keep the dies closed.
3. Check the clearance between the bottoming surfaces of the crimping dies. If the clearance is .001 in. or less, the ratchet is satisfactory. If clearance exceeds .001 in., the ratchet is out of adjustment and must be repaired (see Paragraph II-2, REPAIR).

If the tool conforms to these inspection procedures, lubricate it with a THIN coat of any good No. 20 SAE motor oil and return it to service.

II-2. REPAIR

Parts other than those specified in Figure II-1 must be replaced by AMP to ensure quality and reliability of the tool. When repair is necessary, return the tool with a written description of the problem to:

AMP Incorporated
 Customer Repair
 1523 North 4th Street
 Harrisburg, PA 17102-1604

or a wholly owned subsidiary of AMP Incorporated.