

NOTE



All numerical values are in metric units [with U.S. customary units in brackets]. Dimensions are in millimeters [and inches]. Unless otherwise specified, dimensions have a tolerance of ± 0.13 [± 0.005] and angles have a tolerance of $\pm 2^\circ$. Figures and illustrations are for identification only and are not drawn to scale.

1. INTRODUCTION

This specification covers the requirements for application of Retention Modules for 1 mm [.039 in.] Standard Edge Connectors on 1 mm [.039 in.] centers on a printed circuit (pc) board. The one-piece module is used for mechanical support for the Single Edge Contact Cartridge (SECC); and the two-piece configuration supports the Single Edge Processor Package (SEPP). The retention modules are made of black polycarbonate and have either brass captive fasteners with stud bridge assemblies or pc board locking pins. See Figure 1.

When corresponding with Tyco Electronics Personnel, use the terminology provided on this specification to help facilitate your inquiry for information. Basic terms and features of components are provided in Figure 1.

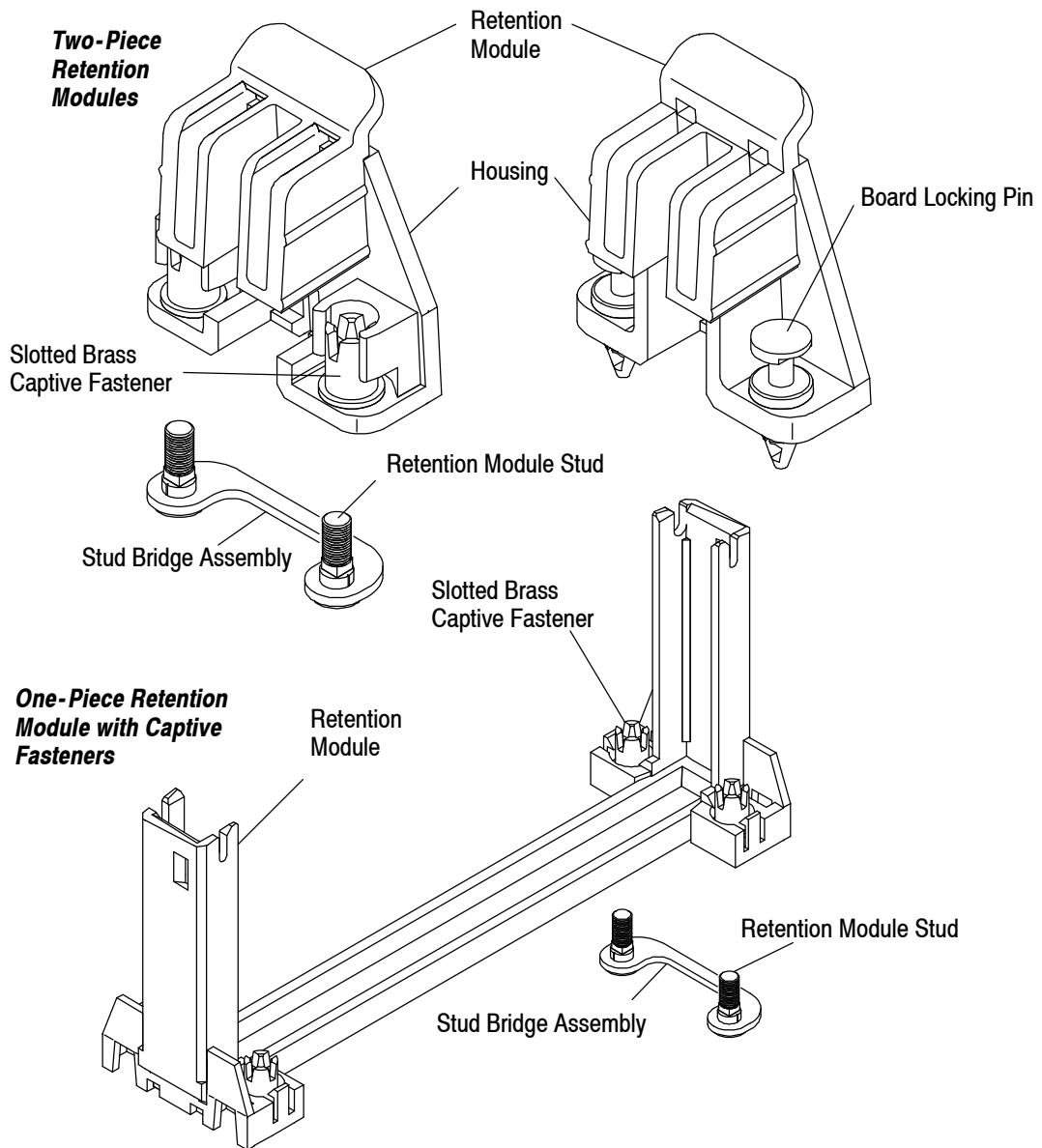

Figure 1 (cont'd)

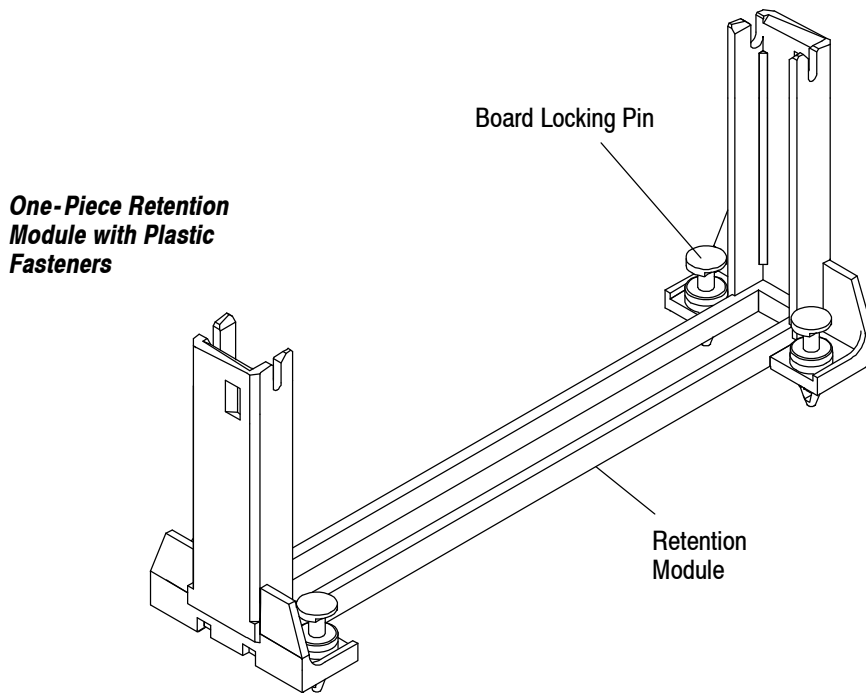

Figure 1 (end)

2. REFERENCE MATERIAL

2.1. Revision Summary

This paragraph is reserved for a revision summary covering the most recent additions and changes made to this specification which include the following:

- Updated to current application specification requirements
- New logo and format

2.2. Customer Assistance

Reference Part Number 145342 and Product Code 2157 are representative numbers of Retention Modules for 1 mm Standard Edge Connectors. Use of these numbers will identify the product line and expedite your inquiries through a service network established to help you obtain product information. Such information can be obtained through a local Tyco Electronics Representative or, after purchase, by calling the Tooling Assistance Center or the Product Information Center number at the bottom of page 1.

2.3. Drawings

Customer Drawings for retention modules are available from the service network. The information contained in Customer Drawings takes priority if there is a conflict with this specification or with any technical documentation supplied by Tyco Electronics.

2.4. Specifications

Product Specification 108-1826 provide product performance requirements and test information.

3. REQUIREMENTS

3.1. Storage

A. Ultraviolet Light

Prolonged exposure to ultraviolet light may deteriorate the chemical composition used in the retention module material.

B. Shelf Life

To prevent damage to the retention modules, they should remain in the shipping containers until ready for installation. Also, to prevent possible storage contamination, the modules should be used on a first in, first out basis.

C. Chemical Exposure

Do not store modules using brass captive fasteners near any chemical listed below as they may cause stress corrosion cracks in the fasteners.

Alkalies	Ammonia	Citrates	Phosphates	Citrates	Sulfur Compounds
Amines	Carbonates	Nitrites	Sulfur Nitrites		Tartrates

3.2. Spacing

NOTE



Careful consideration to the tolerances must be observed when more than one modular pair is to be used on pc boards. See Figure 2. Tolerance build-up on the pc board in conjunction with the tolerances associated with placing the connectors could cause a stress load on the solder joints of the connectors which could affect their reliability.

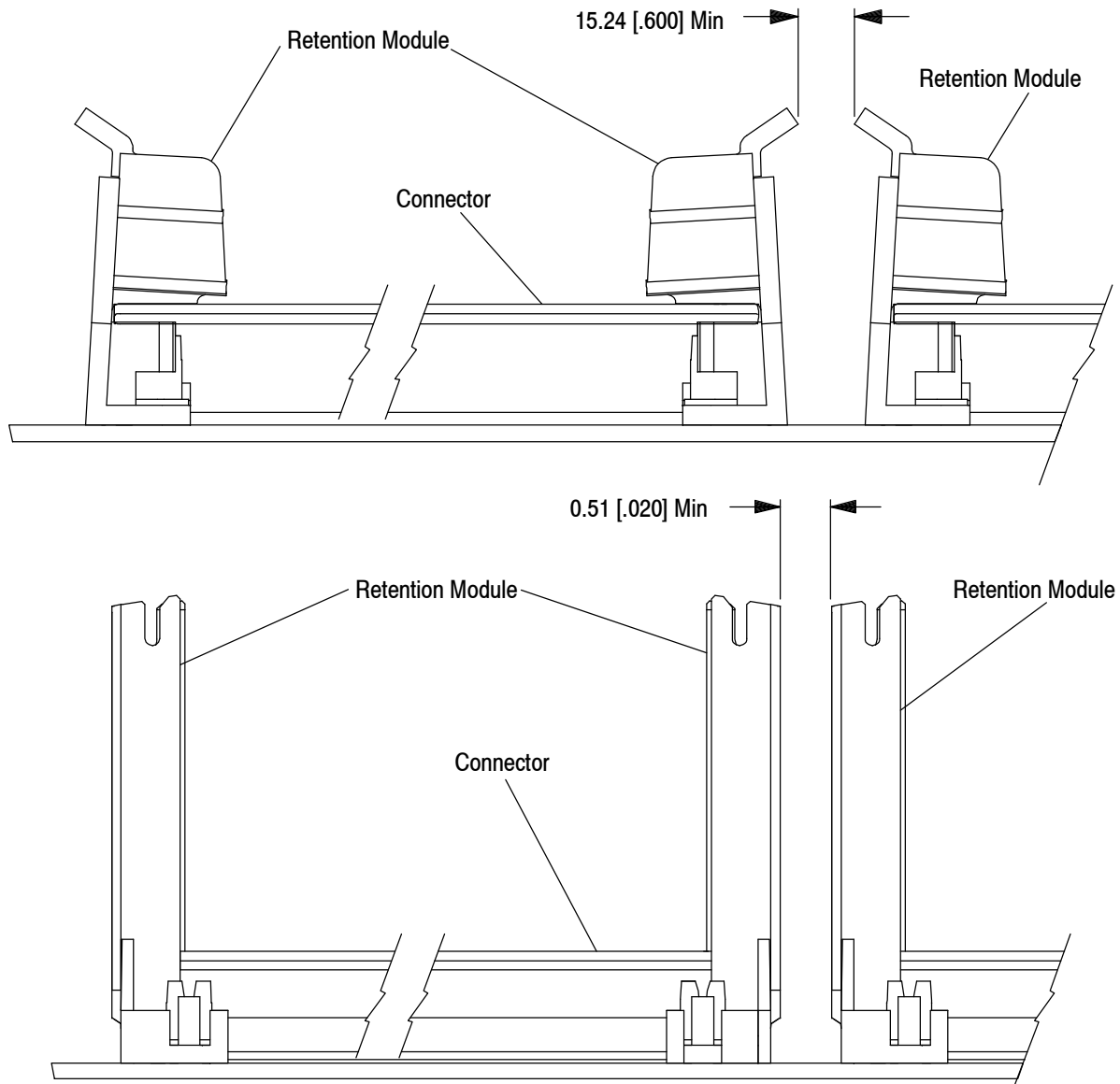

Figure 2

3.3. PC Board Requirements

A. Material and Thickness

The pc board material shall be glass epoxy (FR-4 or G-10). The thickness of the pc board should be 1.57 ± 0.15 mm [$.062 \pm .006$ in.] thick to ensure retention and stability for which the modules are designed. Consult Tyco Electronics for suitability of other materials.

B. PC Board Layout

Recommended pc board patterns for module installation is provided in Figure 3.

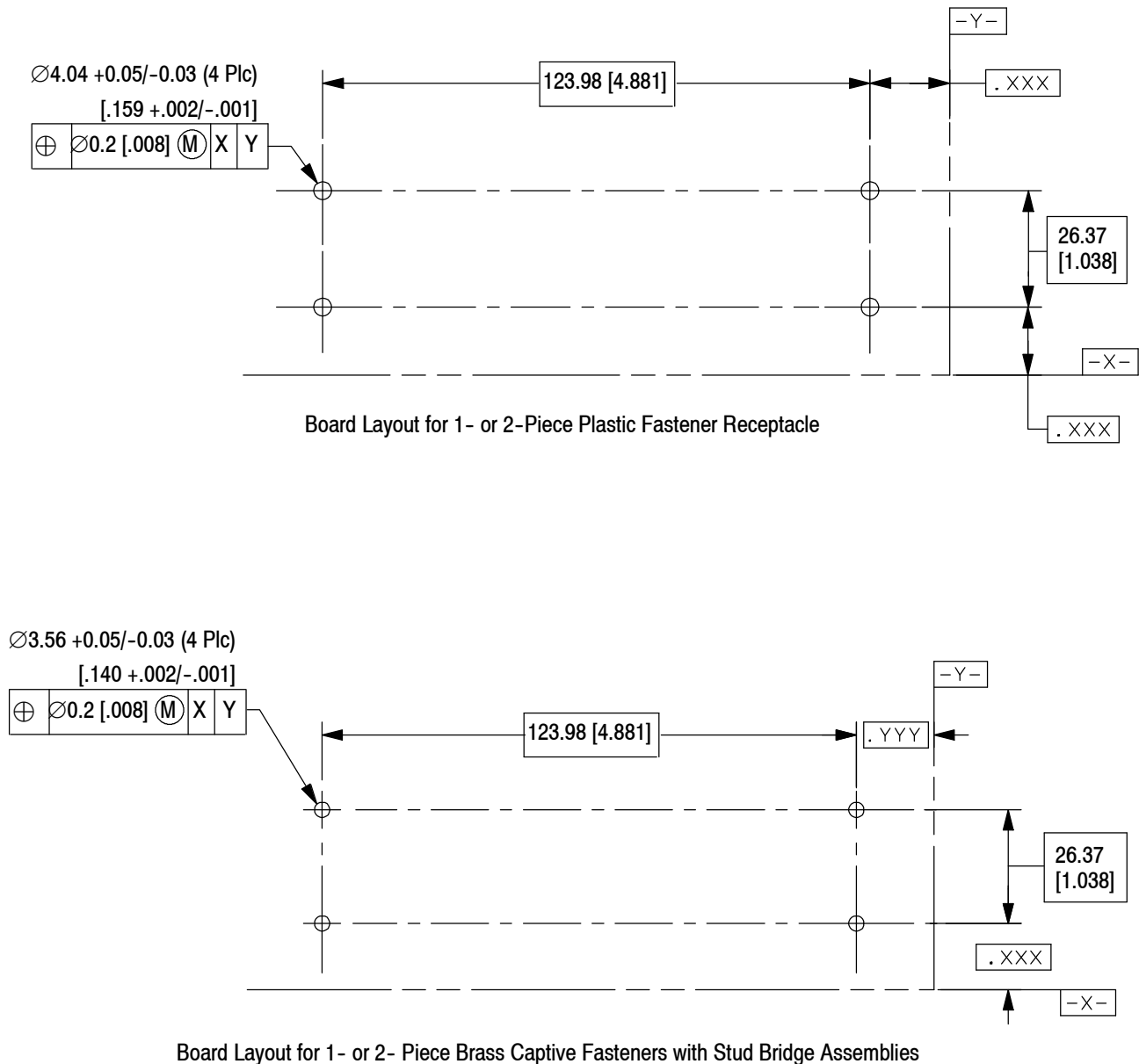

NOTE: Datum and basic dimensions established by customer.

Figure 3

3.4. Module Insertion and Seating

The retention module must seat on the pc board to the dimensions shown in Figure 4. The bridge assembly retention module must be located with the pc board layout holes and fastened securely using a standard flat-blade screwdriver tightening the brass captive fasteners to the stud bridge assembly. The press lock retention module is located on the pc board layout and requires a seating force of 13 to 22 N [3-5 lbs] to insert the module with the hollow posts. An insertion force of 66 N [15 lbs] is required to insert each of the inserting pins into the hollow posts.

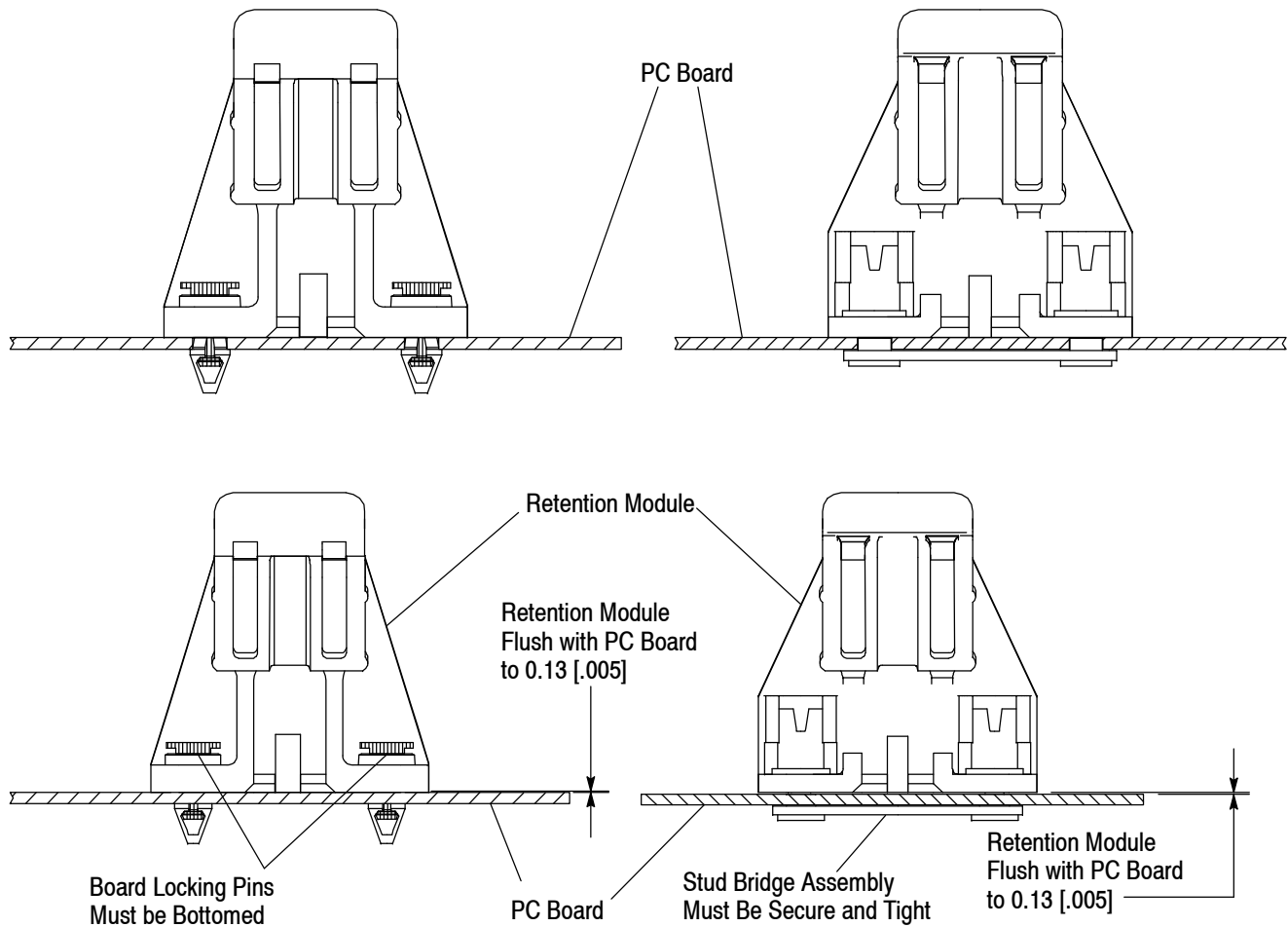

NOTE: Two-piece shown, but dimensions are the same for one-piece configuration.

Figure 4

3.5. Repair/Replacement

Retention Modules must be replaced if damaged or broken. Remove retention modules before the connector. Unseat the locking pins from top, or unscrew the brass captive fasteners; then remove modules from the pc board.

4. QUALIFICATIONS

Retention Modules for 1 mm Standard Edge Connectors are not required to be agency approved.

5. TOOLING

No specific tooling is required for the insertion or application of Retention Modules except a standard flat-blade screwdriver for tightening the brass captive fasteners to the stud bridge assembly.

6. VISUAL AID

Figure 5 shows a typical application of Retention Modules for 1 mm Standard Edge Connectors. This illustration should be used by production personnel to ensure a correctly applied product. Applications which DO NOT appear correct should be inspected using the information in the preceding pages of this specification and in the instructional material shipped with the product or tooling.

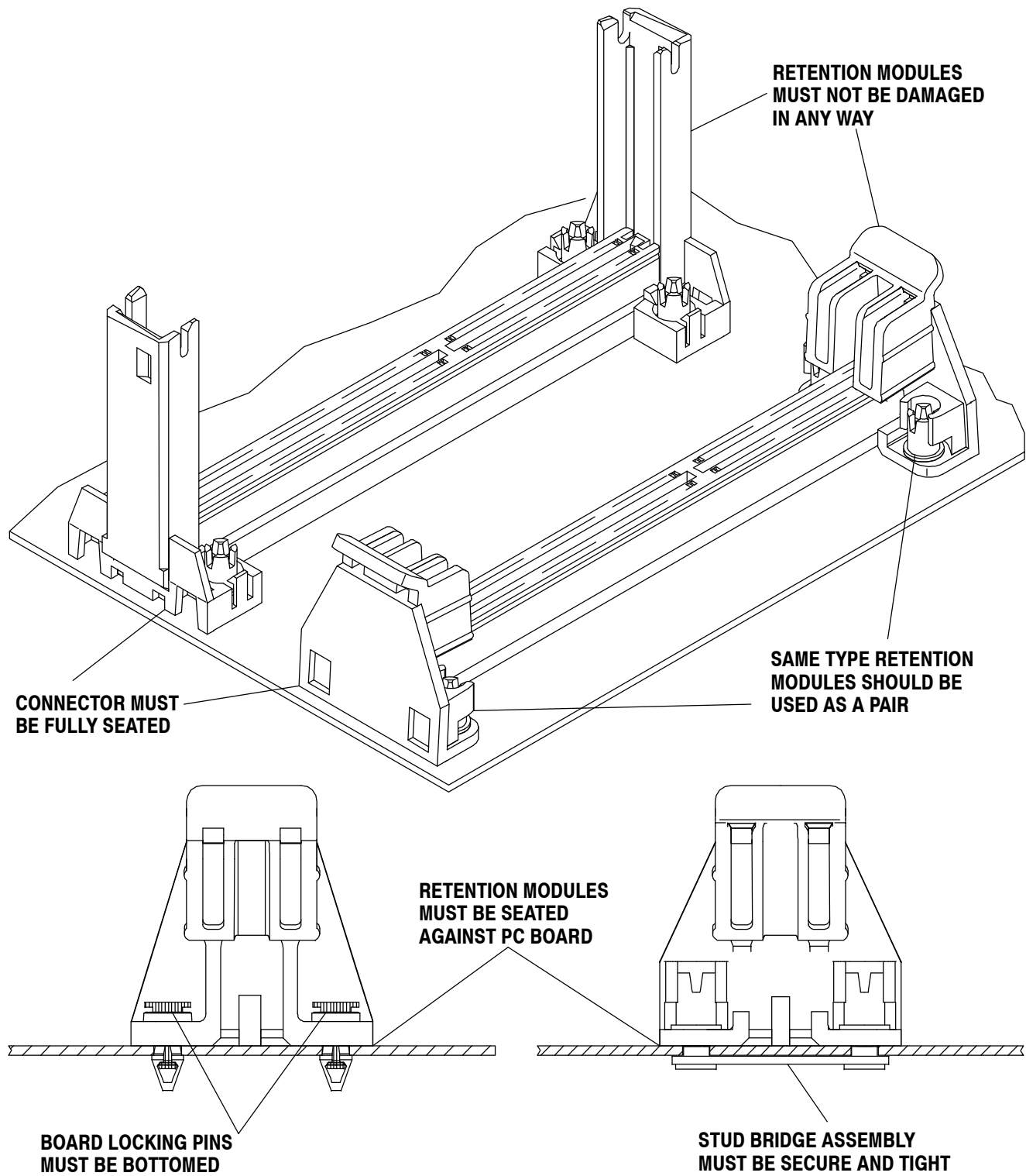

FIGURE 5. VISUAL AID