

SUPER SEAL CONNECTOR 44 Position

1. SCOPE

This specification applies to the SUPER SEAL Connector.

2. APPLIED STANDARD

The following standards are applied as a part of this specification sheet.

SPEC. No.	NAME
JIS D0203	Wet-Proof & Water-Proof Test Method Automobile Parts
JIS Z8901	Dusts and Aerosols for Industrial Testing
MIL 202	Test Methods for Electronic and Electrical Component Parts

501-5386-1 : Qualitification Test Report

3. PRODUCT TYPES

	構成	No. of Pos.	Part No.
Cap housing Connector	Cap Housing Assembly	44	5-6447223-7 5-6447223-9
Plug Housing Connector	Receptacle Contact Assembly	—	3-1447221-3
		—	3-1447221-4
	Plug Housing Assembly	44	2-1447232-6 1376886-1
Accessory	Cavity Plug	—	4-1437284-3

4. MATERIAL

Per the drawing. Drawing Number : 1376885、1376886、3-1447221-3、4-1437284-3

5. DIMENSION AND CONFIGURATION

Per the drawing. Drawing Number : 376885、1376886、3-1447221-3、4-1437284-3

6. RATING

Item	Rating & Condition
Current	Refer to the table below
Voltage	250V (AC, DC)
Temperature	-40~+125°C
Wire	Conductor 0.5~1.25mm ² Insulation Cover ϕ 2.0~ ϕ 2.4 (2-1447232-6) ϕ 1.6~ ϕ 2.2 (1376886-1)

Connector Allowable Current

(Allowable maximum temperature in the vicinity of the contacting point is 150°C)

(A)

Measurement Set-up		Ambient Temperature	60	80	100	125
		(°C)				
(Wire Size 0.85mm ² min.)	All positions active		7	6	5	3
	Only single position active		15	13	11	6



7. MEASUREMENT METHOD AND PERFORMANCE

No.	ITEM	MEASUREMENT METHOD	PERFORMANCE
7.1	External Appearance	Visual and touch feeling inspection.	There shall be no detrimental crack, rust, play, scratch, deformation and etc.
7.2	Feeling on Mating /Unmating	Feeling is verified by mating and unmating the contact, housing and connector	There should be no detrimental binding.
7.3	Insertion Force	Pin contact or cap housing connector is fastened first, then receptacle contact or plug housing and plug connector are mated at a constant mating speed of approx. 100mm/min. or less toward the axis.	Contact 4.9N or less Housing 58.8N or less Connector 137.2N or less
7.4	Withdrawal Force	Pin contact or cap housing connector is fastened first, then mated receptacle contact or plug housing and the connector is pulled at a constant speed of approx. 100mm/min. or less toward the axis. (Plug housing should be installed without locking.)	Contact 4.9N or less Housing 58.8N or less Connector 137.2N or less

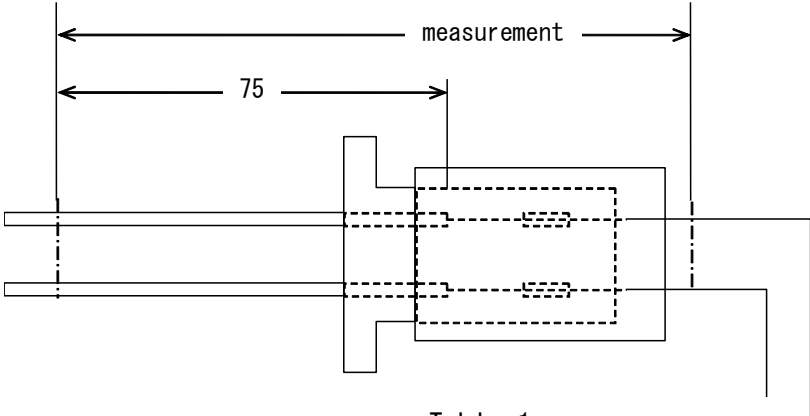
No.	ITEM	MEASUREMENT METHOD	PERFORMANCE									
7.5	Voltage Drop	<p>As shown in Fig.1 while feeding open voltage of $20\pm 5\text{mV}$ and short circuit current of $10\pm 0.5\text{mA}$ to the mated connector, measurement is taken at the point 75mm apart from the crimped barrel when temperature of the mated contact has saturated and then voltage drop by the wire is subtracted. (Resistance of wire is per Table 1.)</p> <p>Fig. 1</p>  <p>Table 1</p> <table border="1" data-bbox="707 1026 1191 1313"> <thead> <tr> <th rowspan="2">Wire Size</th> <th>Resistance</th> </tr> <tr> <th>($\text{m}\Omega / 75\text{mm}$)</th> </tr> </thead> <tbody> <tr> <td>0.5</td> <td>2.45</td> </tr> <tr> <td>0.85</td> <td>1.56</td> </tr> <tr> <td>1.25</td> <td>1.07</td> </tr> </tbody> </table>	Wire Size	Resistance	($\text{m}\Omega / 75\text{mm}$)	0.5	2.45	0.85	1.56	1.25	1.07	<p>Initial : $5\text{m}\Omega$ or less</p> <p>After Durability Test : $10\text{m}\Omega$ or less</p>
Wire Size	Resistance											
	($\text{m}\Omega / 75\text{mm}$)											
0.5	2.45											
0.85	1.56											
1.25	1.07											

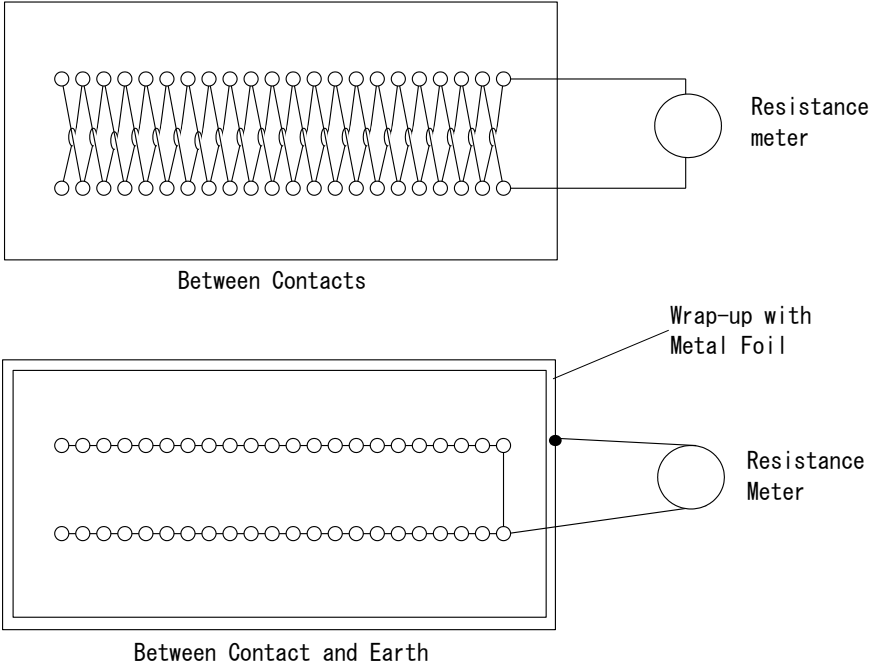
No.	ITEM	MEASUREMENT METHOD	PERFORMANCE
7.6	Insulation Resistance	<p>As shown in Fig.2 the connector is mated and insulation resistances between neighboring contacts and between contact and earth are measured with insulation resistance meter of DC 500V.</p> <p style="text-align: center;">Fig. 2</p> 	100MΩ or more
7.7	Dielectric Withstanding Voltage	<p>As shown in Fig. 2 while the connector is mated, 1000VAC or 1600V DC voltage of commercial power frequency is applied of duration of 1 minute between contacts and between contact and earth.</p>	Insulation breakdown does not develop.

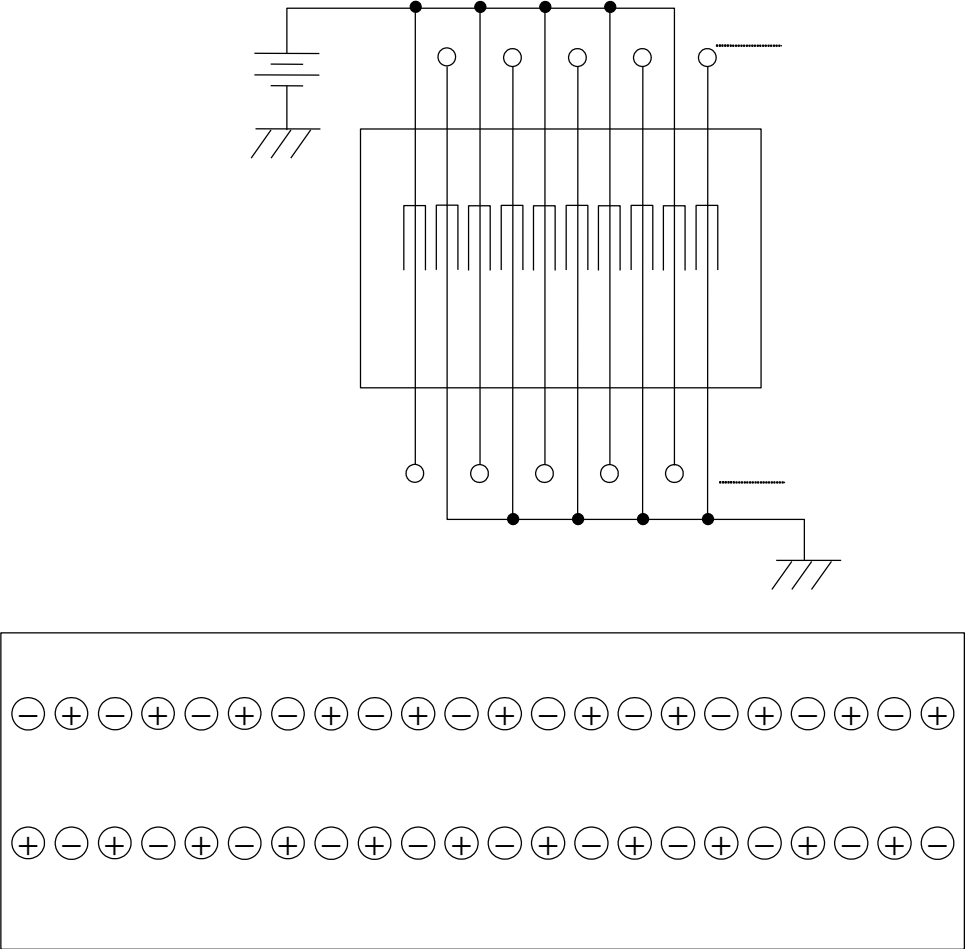
No.	ITEM	MEASUREMENT METHOD	PERFORMANCE
7.8	Leak current	<p>Peak value of leak current and integrated quantity are measured while DC 28 volt is applied with the circuit shown in Fig.3. The wire used for testing should be minimum size.</p> <p style="text-align: center;">Fig. 3</p> 	<p>Peak Value : $100\mu\text{A}$ or less</p>



Product Specification

108-78176-2

No.	ITEM	MEASUREMENT METHOD	PERFORMANCE										
7.9	Contact Solderability	Solder bath : Sn-3Ag-0.5Cu Solder Temperature : 250±5°C Immersion Duration : 5±0.5sec. Flux : ULF-300R	Wet Solder Coverage : (Plated area only) 95% Min.										
7.10	Contact Insertion Characteristic (Between Contact and Housing)	Contact crimped on free-length of wire is inserted into the proper location of the plug housing. Holding position of the wire is 20mm apart from the crimp barrel. Insertion speed is 100mm/min. or less.	Contact can be inserted without bending of wire.										
7.11	Contact Withdrawal Characteristic (Between Contact and Housing)	Withdraw the contact inserted under the condition of 7.10.	There shall be no detrimental binding, crack and deformation.										
7.12	Contact Retention Force (Between Contact and Housing)	About 100mm long wire is crimped with the plug housing connector and the receptacle contact is fastened and then the load that causes separation of contact from the housing with the wire pulled toward the axis at a constant speed of approx. 100mm/min. is measured.	58.8N or more										
7.13	Strength of Crimp Connection (Between Contact and Wire)	After the receptacle contact with wire crimped is fastened and then the load that causes wire breakage or separation of the wire from the crimped barrel with the wire pulled toward the axis at a constant speed of approx. 100mm/min. is measured.	<table border="0"> <tr> <td>Wire size</td> <td></td> </tr> <tr> <td>0.5</td> <td>88.2N or more</td> </tr> <tr> <td>0.75</td> <td>117.6N or more</td> </tr> <tr> <td>0.85</td> <td>127.4N or more</td> </tr> <tr> <td>1.25</td> <td>176.4N or more</td> </tr> </table>	Wire size		0.5	88.2N or more	0.75	117.6N or more	0.85	127.4N or more	1.25	176.4N or more
Wire size													
0.5	88.2N or more												
0.75	117.6N or more												
0.85	127.4N or more												
1.25	176.4N or more												

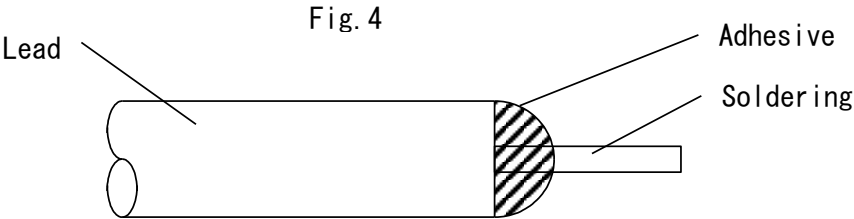
No.	ITEM	MEASUREMENT METHOD	PERFORMANCE
7.14	Housing Retention Force (Housing Locking Strength)	After the cap housing is fastened, mated plug housing is pulled at a constant speed of approx. 100mm/min.	The lock mechanism shall not get released or broken less than 98N(10kgf).
7.15	Seal Ability	<p>Seal Ability is measured with compressed air fed into the water-proof section of the connector. Before running the test, the tip of the wire is soldered and then sealed with adhesives. (Fig. 4)</p> <p>Measurement is taken with 9800Pa(gage) (0.1kg/cm²) compressed air fed into the connector submerged for duration of 30 seconds. If the air does not leak for 30 seconds, the pressure is raised each time by an increment of 9800Pa(gage) (0.1kg/cm²).</p> <div data-bbox="555 754 1406 973" style="text-align: center;"> <p>Fig. 4</p>  <p>The diagram shows a cylindrical lead with a hatched hemispherical tip. A label 'Lead' points to the main body. A label 'Adhesive' points to the hatched tip. A label 'Soldering' points to a small rectangular protrusion on the side of the tip.</p> </div>	<p>Initial : 98KPa(gage) or more</p> <p>After Durability Test : 49KPa(gage) or more</p>

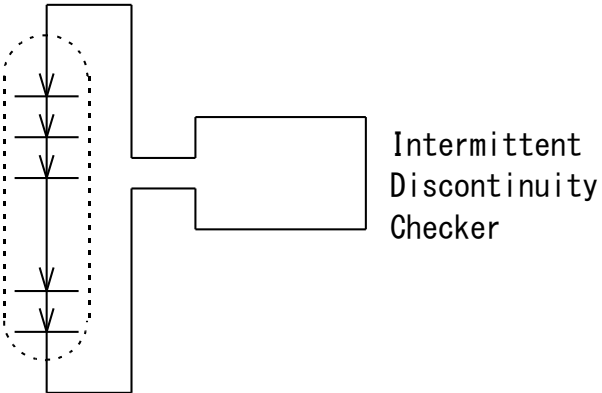
No.	ITEM	MEASUREMENT METHOD	PERFORMANCE
7.16	Temperature Rise Magnitude	<p>“Temperature Rise Test” of item No. 8.16 is made and temperature of connector surface near the mated interface of the contact, is measured when the temperature has saturated.</p>	<p>Temperature rise: 60°C or less.</p>
7.17	Intermittent Discontinuity	<p>Power of 12V or less open voltage and 1A or less short circuit current is applied to the mated connector with the contacts in all positions connected in series and then intermittent discontinuity is monitored with an intermittent discontinuity detector. (Fig. 5)</p> <p style="text-align: center;">Fig. 5</p> <div style="display: flex; align-items: center; justify-content: center;"> <div style="margin-right: 20px;">Connector</div>  </div>	<p>Intermittent discontinuity shall not last for 10 μsec or more.</p>

8. TEST STRUCTURE AND SEQUENCE

8.1 Characteristic Test

The test is made basically in line with the sequence shown in the Table 3.

Table 3

Test Sample Sequence	Contact	Housing	Connector
1	External Appearance	External Appearance	External Appearance
2	Insertion Force	Insertion Force	Contact Insertion Characteristic
3	Withdrawal Force	Withdrawal Force	Insertion Force
4	Feeling of mating/unmating	Feeling of mating/unmating	Withdrawal Force
5	Contact Force	Housing Retention Force	Feeling of mating/unmating
6	—	—	Contact Withdrawal Characteristic
7	—	—	Contact Retention Force
8	—	—	Contact Solderability

8.2 Durability Test

The test is made basically according to the Table 4.

Table 4

Sequence Group Designation	BEFORE TEST	TEST I	TEST II	TEST III
A	—	“Kojiri” durability	Vibration	Current cycle
	Low level voltage and current resistance	Low level voltage and current resistance External Appearance	Intermittent discontinuity※ External Appearance※ Low level voltage and current resistance	Low level voltage and current resistance External Appearance
B	—	“Kojiri” durability	Temperature rise	—
	Low level voltage and current resistance	Low level voltage and current resistance External Appearance	Temperature rise※ Low level voltage and current resistance	—
C	—	High temperature exposure	Low temperature exposure	—
	Insertion force Low level voltage and current resistance Seal ability Withdrawal force	Low level voltage and current resistance Seal ability Withdrawal force Insertion force	Low level voltage and current resistance Seal ability Withdrawal force Insertion force	—
D	—	Thermal shock	Water-Proof	—
	Insertion force Low level voltage and current resistance Seal ability Withdrawal force	Low level voltage and current resistance Seal ability Withdrawal force Insertion force	Leak current※ Low level voltage and current resistance Seal ability Withdrawal force Insertion force	—
E	—	Over-current	—	—
	External appearance	External appearance	—	—
F	—	“Kojiri” durability	Dust-proof	Oil-proof, Solvent-proof
	Insertion force Low level voltage and current resistance Insulation resistance Withdrawal force	Low level voltage and current resistance External appearance	Low level voltage and current resistance	Low level voltage and current resistance Insulation resistance Withdrawal force Insertion force External appearance
G	—	Freezing	Corrosion gas	Ozone deterioration
	Low level voltage and current resistance Insulation resistance Seal ability	Leak current	Low level voltage and current resistance Seal ability	Low level voltage and current resistance Insulation resistance Seal ability External appearance
H	—	Salt Spray	—	—
	Low level voltage and current resistance	Leak current※ Low level voltage and current resistance	—	—

Sequence Group Designation	BEFORE TEST	TEST I	TEST II	TEST III
I	—	Weather-proof	—	—
	insertion force Low level voltage and current resistance Insulation resistance Withstanding voltage Withdrawal force	Low level voltage and current resistance Insulation resistance Withstanding voltage Withdrawal force Insertion force	—	—
J	—	High pressure cleaning	—	—
	External appearance	Leak current External appearance	—	—

Note※: This measurement item is continually measured thru the test.

- Remark :
1. The test subject and item to be measure are shown above and below the dotted line respectively in the Table 4.
 2. The measurement items shall be measured one after another sequentially in each item.

9. TEST METHOD

9.1 “Kojiri”*(Rocking motion) Durability Test

After the cap housing connector is fastened, the plug housing is mated in the regular manner and then 78.4N (8kgf) force is applied to-and-fro twice as shown in Fig.6. This test is repeated with the connector half if pulled from other half with slide distance stepped up by an increment of 1mm each time until the connector is fully unmated. These test procedure is defined as one cycle and is repeated 25 cycles. Test with the force applied towards right and left, is also made in the same manner. (Test with the force applied towards combined direction of to/fro and right/left is also acceptable.)

Fig.6

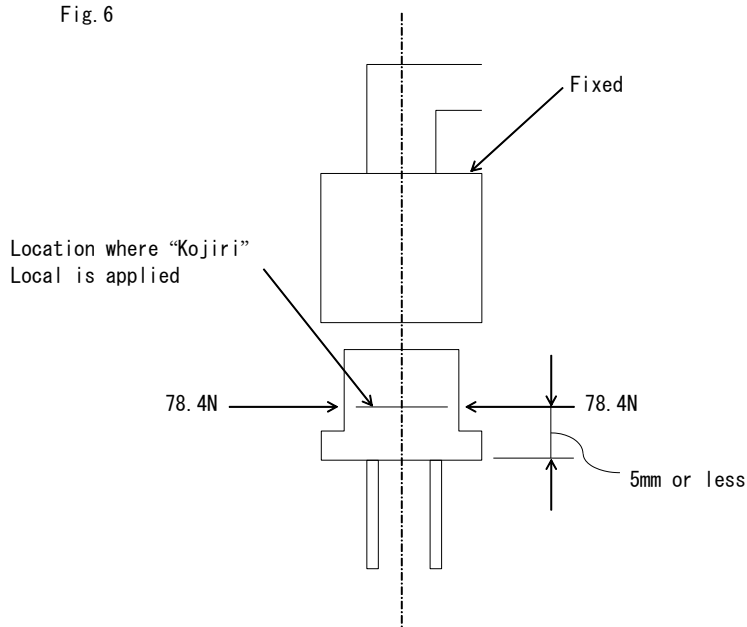

9.2 High Temperature Exposure Test

The connector is kept in a thermostatic chamber for 1000 hours and then taken out to be exposed to the normal temperature until it cools off to the temperature. The chamber temperature is set at 125°C.

9.3 Low Temperature Exposure Test

The same test procedure as above is made except that the exposure time is 150 hours and the chamber temperature is set at -40°C.

9.4 Thermal Shock Test

The connector is placed in a thermostatic chamber and given with 200cycles of heating/cooling process in the heating/cooling pattern shown below and then is taken out of the chamber to be left in the normal temperature for more than 2hours.

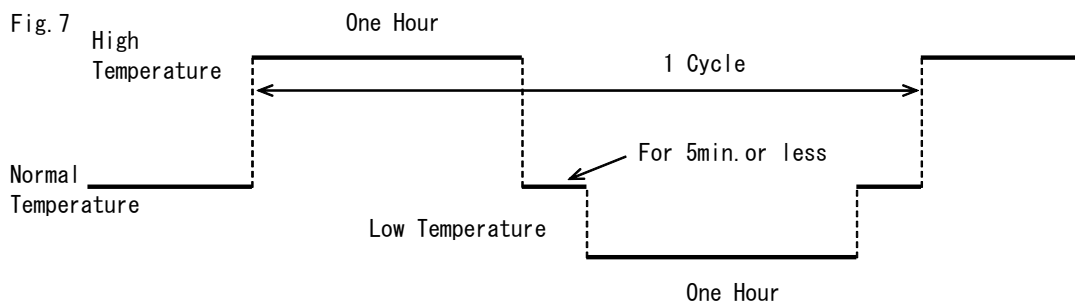

Thermostatic chamber temperature is set at 125°C as the high temperature and -40°C as the low temperature

9.5 Salt Spray Test

The connector is hung in a sealed tank and sprayed with mist of salt water for 96hours and then hung in a humidity chamber to be left in there for 96hours.

The salt water (35±5°C temperature, 5±1% saltdensity, 1.0268 ~ 1.0413 specific gravity, PH 6.5 ~ 7.2) is sprayed at pressure of 68.6 ~ 176.5KPa(gage) (0.7 ~ 1.8kg/c m²). The humidity chamber is set at temperature of 80±5°C and relative humidity of 90~95%. Measurement is taken after the connector has dried up in normal temperature. During the salt water spray, 28 volt is applied across each contact of the connector to monitor leak current as shown in Fig. 3.

9.6 Oil-Proof, Solvent-Proof Test

The connector is dipped in various oil. Oil temperature is set at $50\pm 2^{\circ}\text{C}$.

Test is made in the sequence shown below.

Torq. Con. Oil (Castle Auto Fluid Special)	Dipping for 1hour → Dipping in kerosene for 5min.
→ Transmission Oil (SAE 90)	Dipping for 1hour → Dipping in kerosene for 5min.
→ Engine Oil (SAE 10W-30)	Dipping for 1hour → Dipping in kerosene for 5min.
→ Clutch oil (Toyota Standard SHD)	Dipping for 1hour → Dipping in kerosene for 5min.
→ Brake Oil (Toyota Standard SHF)	Dipping for 1hour → Dipping in kerosene for 5min.

Another dipping test is also made on other sample in the following sequence with oil temperature set at $50\pm 2^{\circ}\text{C}$.

Washer liquid (available in the market) Dipping for 1hour

- Rinsing and dipping with or in tap water for 5min.
- Antifreezing solution (Castle Long Life Coolant) Dipping for 1hour
- Rinsing and dipping with/or in tap water 5min.
- Drying while left in room temperature

9.7 Water-Proof Test

The connector is placed in the thermostatic chamber, heated up 40min. and then immediately sprayed with water of normal temp. for 20min. in an water-proof test chamber. This is defined as 1cycle. The cycle is repeated 48 times for the test. The spray is made according to S2 of JIS D0203. Potential of 28 volt is applied across each contact of the connector during the water spray by the circuit shown in the Fig.3 and leak current is monitored. At running the test, the leading end of the lead wire shall be pulled out from the test chamber after having been soldered and then sealed with adhesives. The thermostatic chamber is set at 125°C.

9.8 Freezing Test

The conector is put in a thermostatic chamber set at $-30\pm 5^{\circ}\text{C}$ immediately after dipped in boiling water for 1hour and then taken out of the chamber after the water stuck on the connector has freezed. Potential of 28 volts is applied across each contact of the conector during the test with the circuit shown in Fig.3, and leak current is monitored.

9.9 Corrosion Gas Test

The connector is left in the test chamber for 24hours. The chamber is fed with 10ppmSO₂ gas with 90% or more humidity and set at normal temperature.

9.10 Ozone Deterioration Test

The connector is left in the test chamber for 24hours. The chamber is fed with 50 ± 5 ppm ozone gas and set at 40°C.

9.11 Vibration Test at High Temperature

The connector is fastened to vibration stand and vibrated on each of the 3 mutually perpendicular axis (X, Y, Z) in 125°C atmosphere. Other condition of the vibration is set by the Table 5. During the test, electrical current is turned on as shown in Fig. 8 and intermittent discontinuity is monitored.

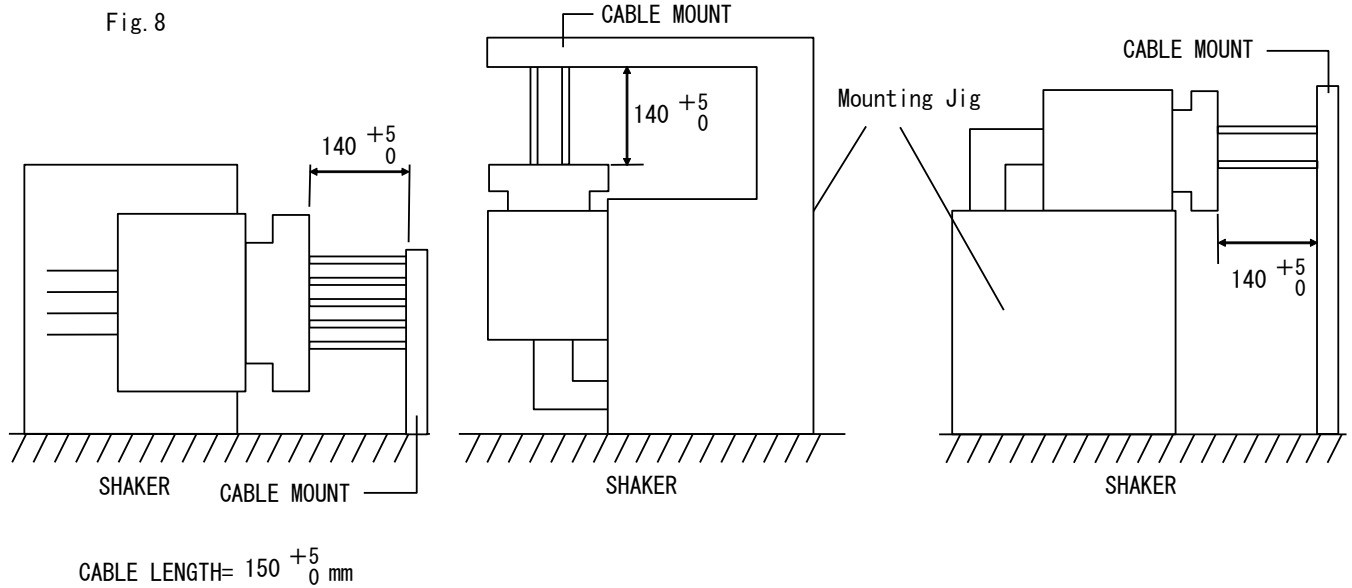
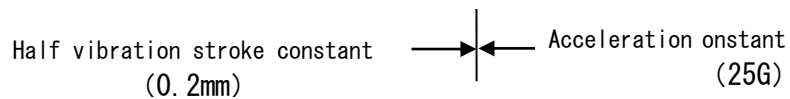

Table 5

Acceleration (m/s ²)	Vibration Duration (h)	Vibration Frequency (Hz)
98~245 (10~25G)	3 hours per direction, Total of 9 hours	50~100 ... 98m/s ² (10G) constant 100~250* ... Half vibration stroke of 0.2mm constant ~245m/s ² (25G) constant Sweep Time 3min. (Log Sweep)

* 100~176~250Hz



9.12 Weather-Proof Test

The connector is left in sunny outdoors for 12 months.

9.13 Current Cycle Test

- ① Contacts of signal positions of the connector are turned on with the current of 3 Ampere, and power positions with the current of 4 Ampere. Turning on current for 45 min. and then turning off for 15 min. are defined here as one cycle of test. The connector is tested with 200 cycles.
- ② Contacts of signal positions of the connector are turned on with the current of 3 Ampere and power positions with the current of 8 Ampere shown in fig. 9 at 120°C atmosphere. This test cycle is repeated 50 times with vibration applied in draft free chamber according to the condition specified in the Table 5. The connector is vibrated perpendicular to the terminal axis.

Fig.9

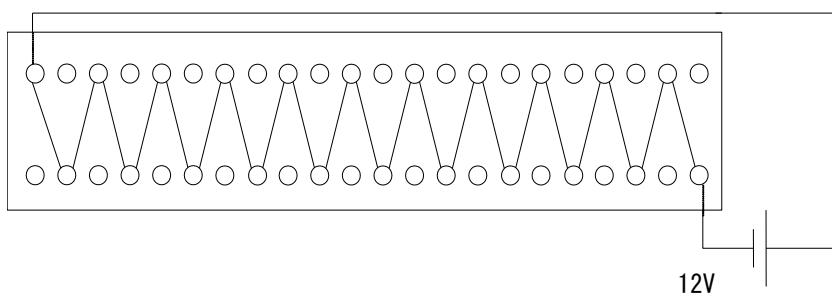

9.14 Over-current Test

While the connector is held horizontally in a draft free chamber, current is turned on thru one circuit arbitrarily chosen. Current magnitude and time length for the over-current test are selected per the Table 6

Table 6

Wire Size	Test ①		Test ②	
	Current Value (A)	Conduction Time (min.)	Current Value (A)	Conduction Time (sec.)
0.5	30	5	80	5
0.85	40		110	
1.25	50		170	

9.15 Dust-Proof Test

Hang the mated connector in the chamber of 900~1200mm each sides. Jet 10 seconds the 1.5Kg of powder specified by JIS Z8901-6 in every 15 minutes. This test cycle is repeated 8 cycles. Unmated and mate the connector in every 2 cycles.

9.16 Temperature Rise Test

Conduct the current of 15 Ampere on an optional contact of the connector, then conduct the current of 6 Ampere on all of the contact. Measurement is based on per temperature rise magnitude 6.16.

9.17 High-Pressure Cleaning Test

Conduct the test accordance with condition specified by Fig. 7 immediate after keeping in 100°C thermostatic chamber for 10 or more minutes. 10 times repeat this test after cooling in room temperature for one minute for each. The cleaning is made around at portion A and B from 60° against the fixed sample. See Fig. 10

A: Cable sealing area

B: Connector dealing area

Do not reuse the samples for cleaning for A or B.

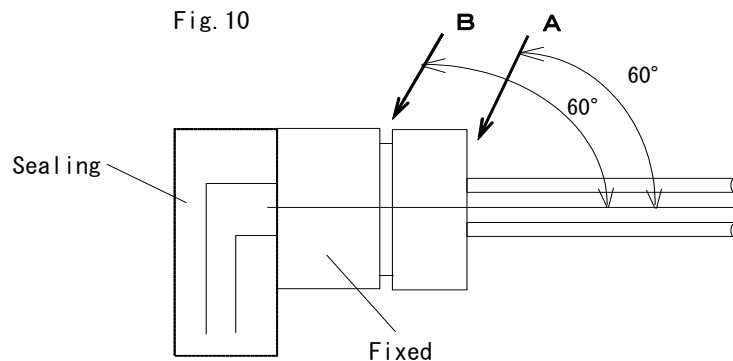

Leak current is measured during the cleaning para 7.8.

Table 7

Item	Requirement
Discharge water pressure	784.53N/cm ² (Default of washer)
Discharge water volume	600ℓ/h min.
Distance from the nozzle	300mm
Cleaning time	30 sec

10. TEST CONDITION

- (1) Contact and housing to be tested are to be selected randomly.
- (2) Contact and housing to be tested are to be crimped with wire of the maximum size except when otherwise noted. Wire length shall be decided each time.
- (3) Wire used in the tests should have enough performance of Heatstability and Solvent-resistance.
- (4) Test is to be made in the normal temperature and humidity except when otherwise noted.
- (5) Test is to be made with the connector mated except when otherwise noted.
- (6) Tolerance of the test conditions is $\pm 10\%$ except when otherwise noted.
- (7) Quantity of test sample will be adjusted depending on situation.
- (8) Measurement for each test is to be made on 2 positions or more.

11. PACKAGING AND MARKING

Packaging units will each contain suitable quantities of the product. Arrangements for transport and storage shall be such that no loss or damage is suffered. The following labeling will be displayed.

- Product description or Cat. No.
- Quantity contained
- Manufacturer's name or abbreviated name
- Date of manufacture or Lot. No.