

DRAWING MADE IN THIRD ANGLE PROJECTION

THIS DRAWING IS UNPUBLISHED. RELEASED FOR PUBLICATION, 19
 © COPYRIGHT 19 BY AMP INCORPORATED. ALL INTERNATIONAL RIGHTS RESERVED.

LOC	DIST	P	F	ZONE	LTR	REVISIONS	DATE	APPD
DF	XO				0	RELEASED NPR 90-0064	3-5-90	PY

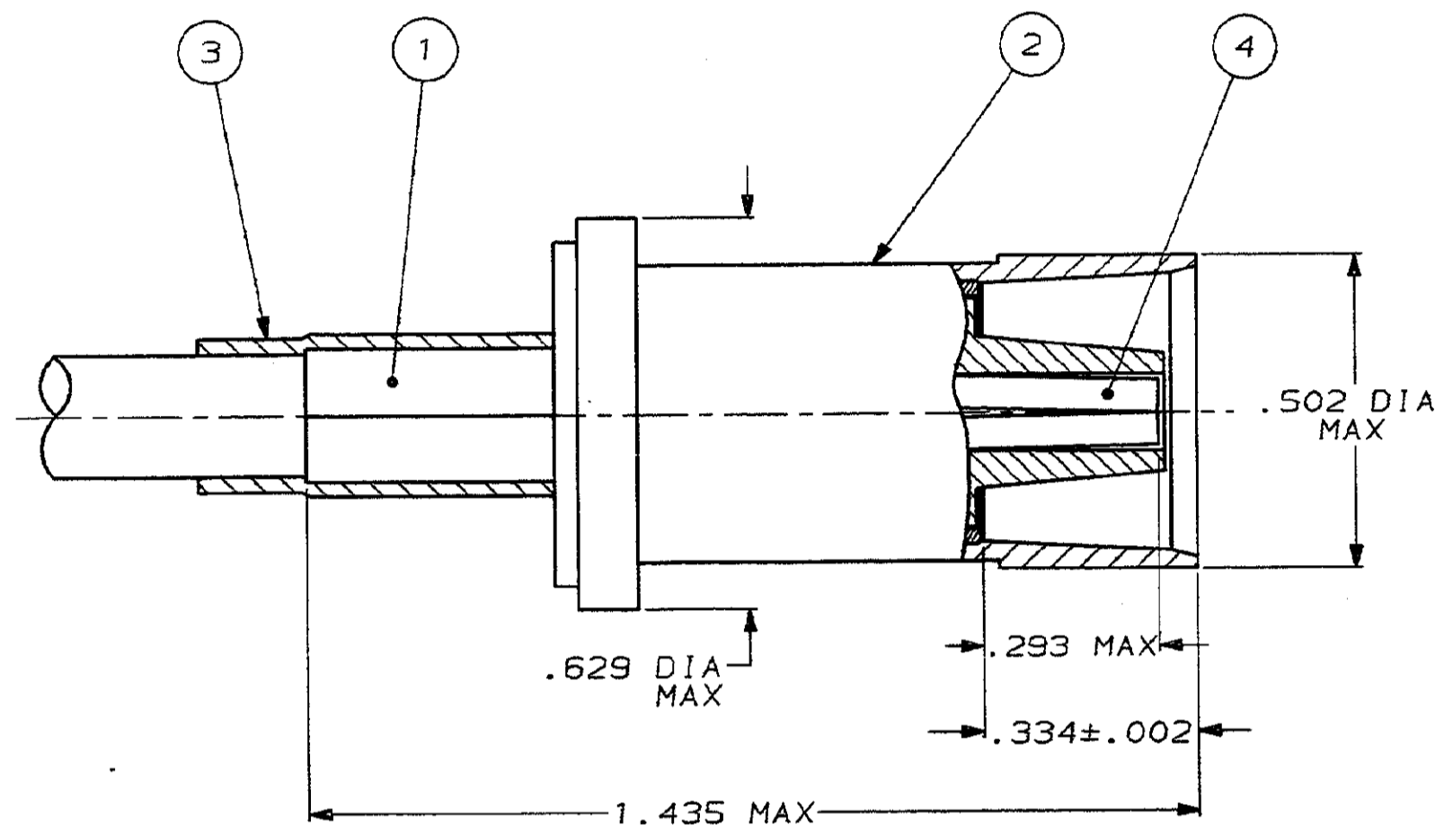

1. FOR USE WITH RG-142/U CABLE
2. BRAID CRIMP: USE MILITARY TOOL M22520/5-01, WITH DIE SET M22520/5-11, CAVITY A OR EQUIVALENT
3. CENTER CONTACT CRIMP: USE MILITARY TOOL M22520/5-01, WITH DIE SET M22520/5-11, CAVITY B OR EQUIVALENT

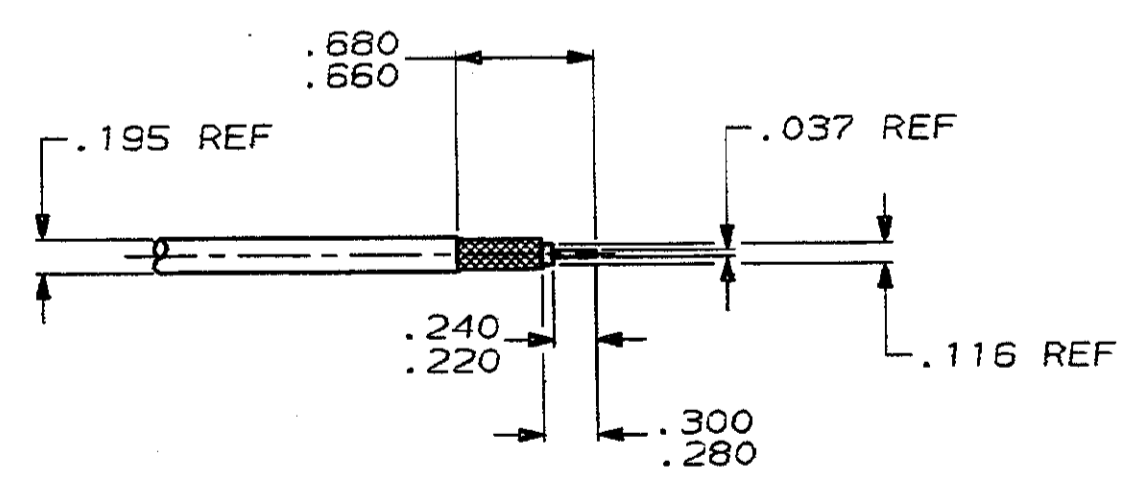

RECOMMENDED STRIP LENGTH
SCALE 1:1

QTY	PART NO	DESCRIPTION	ITEM NO
1	447104-1	CONTACT, ASSEMBLY	4
1	228143-2	HEAT SHRINK TUBING	3
1	447103-1	SOCKET ASSEMBLY	2
1	446556-3	FERRULE	1

DO NOT SCALE PRINT. UNLESS SPECIFIED DIMENSIONS IN INCHES. TOLERANCES ON: 2 PLC DEC ± .005 3 PLC DEC ± .005 ANGLES ± .		DR P. YEAGER 2-13-90	AMP INCORPORATED Harrisburg, Pa. 17105	
MATERIAL -		CHK J. CABARLO 2-26-90		
FINISH -		APPD P. YEAGER 2-28-90	NAME	
WEIGHT -		APPD *	COAXIAL CONTACT, SOCKET, SIZE 1	
		PRODUCT SPEC -	SIZE C	FSCM NO 00779
		APPLICATION SPEC -	SCALE 4:1	DRAWING NO 447087-3
				SHEET 1 OF 1

CUSTOMER DRAWING