

THIS DRAWING IS UNPUBLISHED. RELEASED FOR PUBLICATION 1992
 © COPYRIGHT 2002 BY - ALL RIGHTS RESERVED.

creo
 Creo Parametric 2.0
DO NOT REVISE
EXCEPT BY CAD

REVISIONS				
P	LTR	DESCRIPTION	DATE	APVD
D1		REVISED BY ECLB0427/01	15FEB2002	AP PLF
D2		OBSOLETE VARIANT 444071-9	06OCT2023	KMD SCK

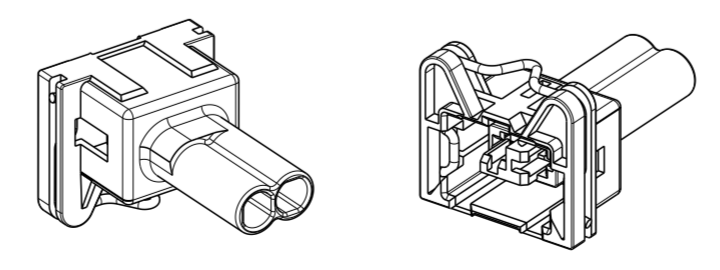
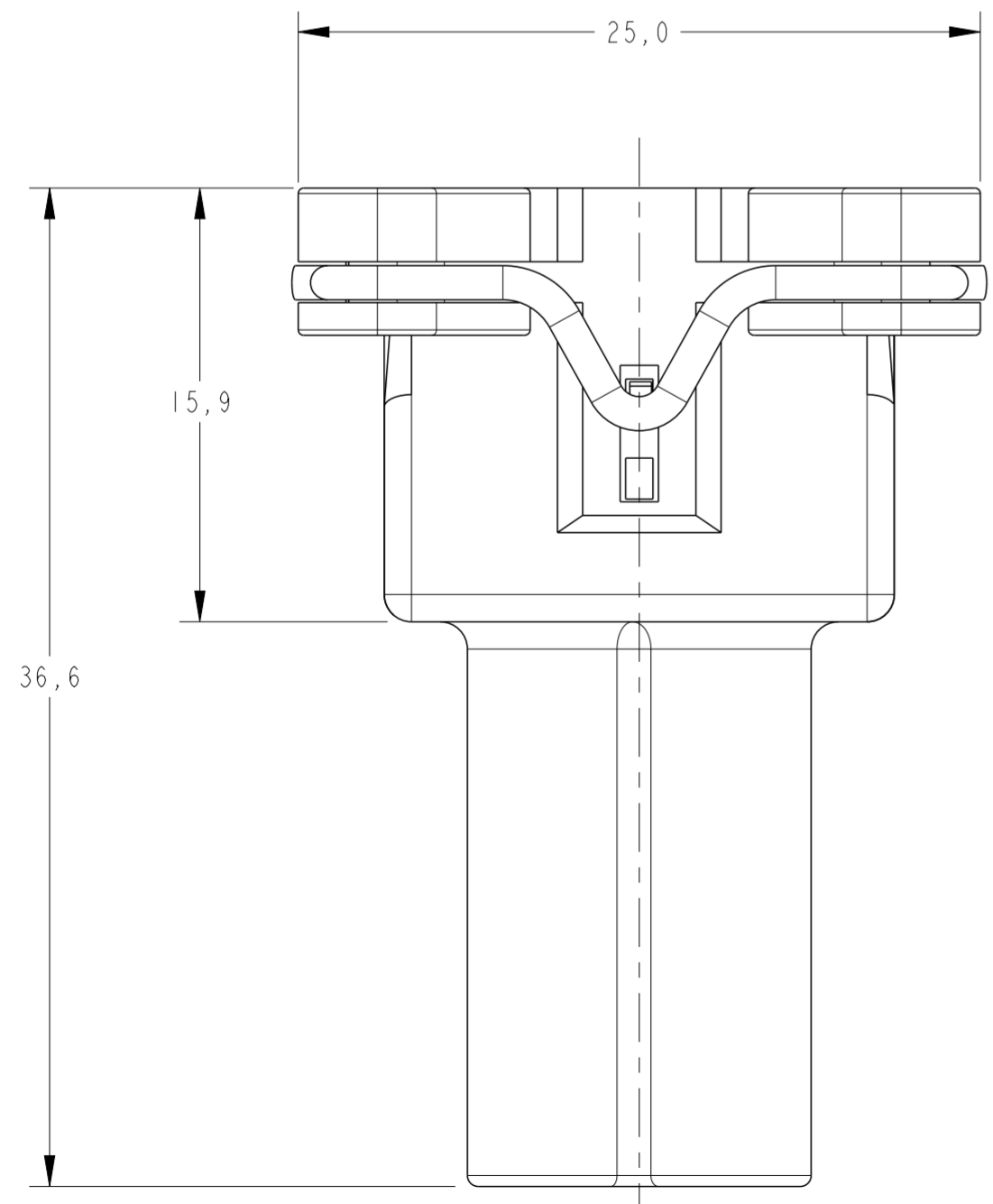
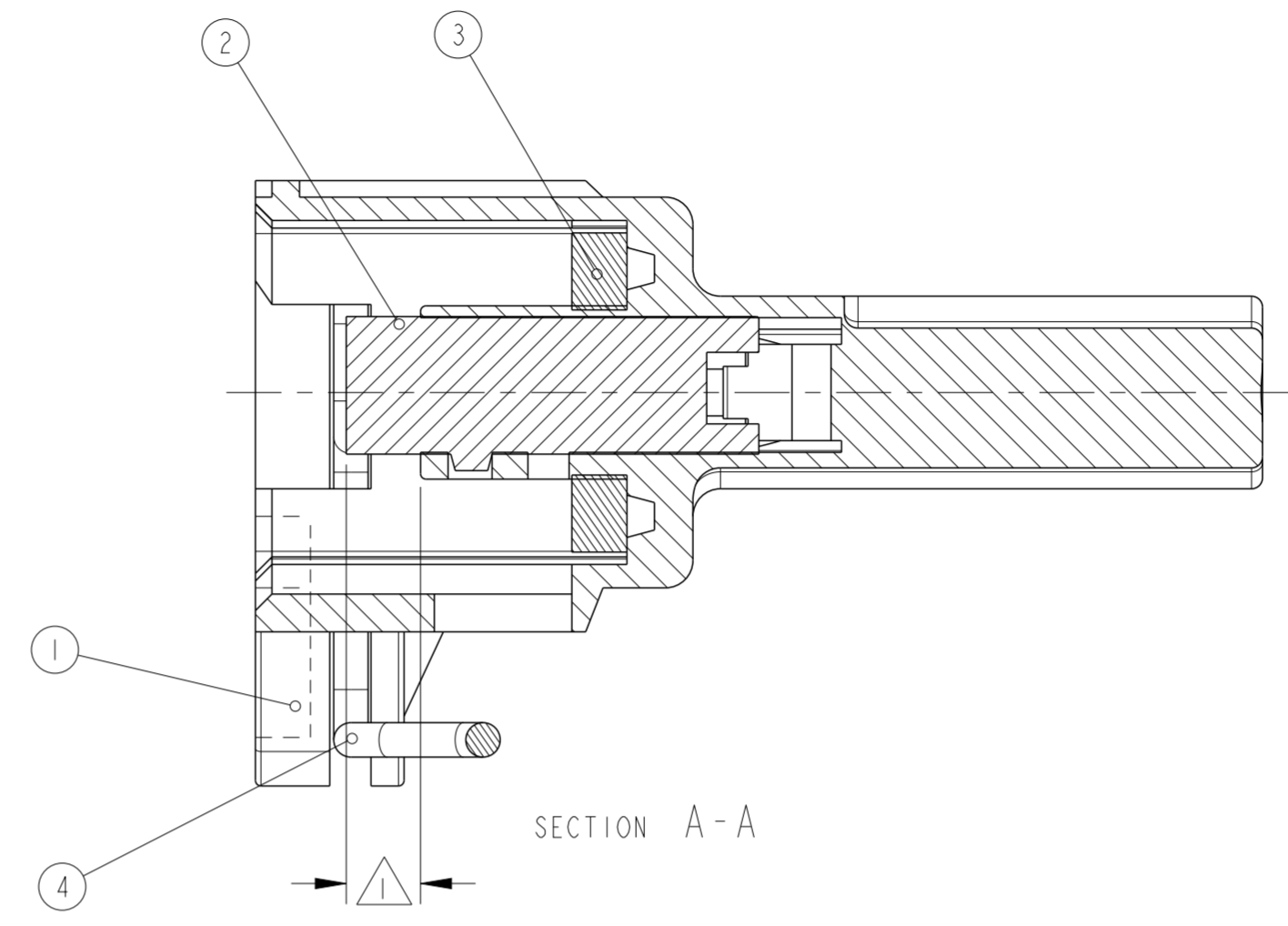
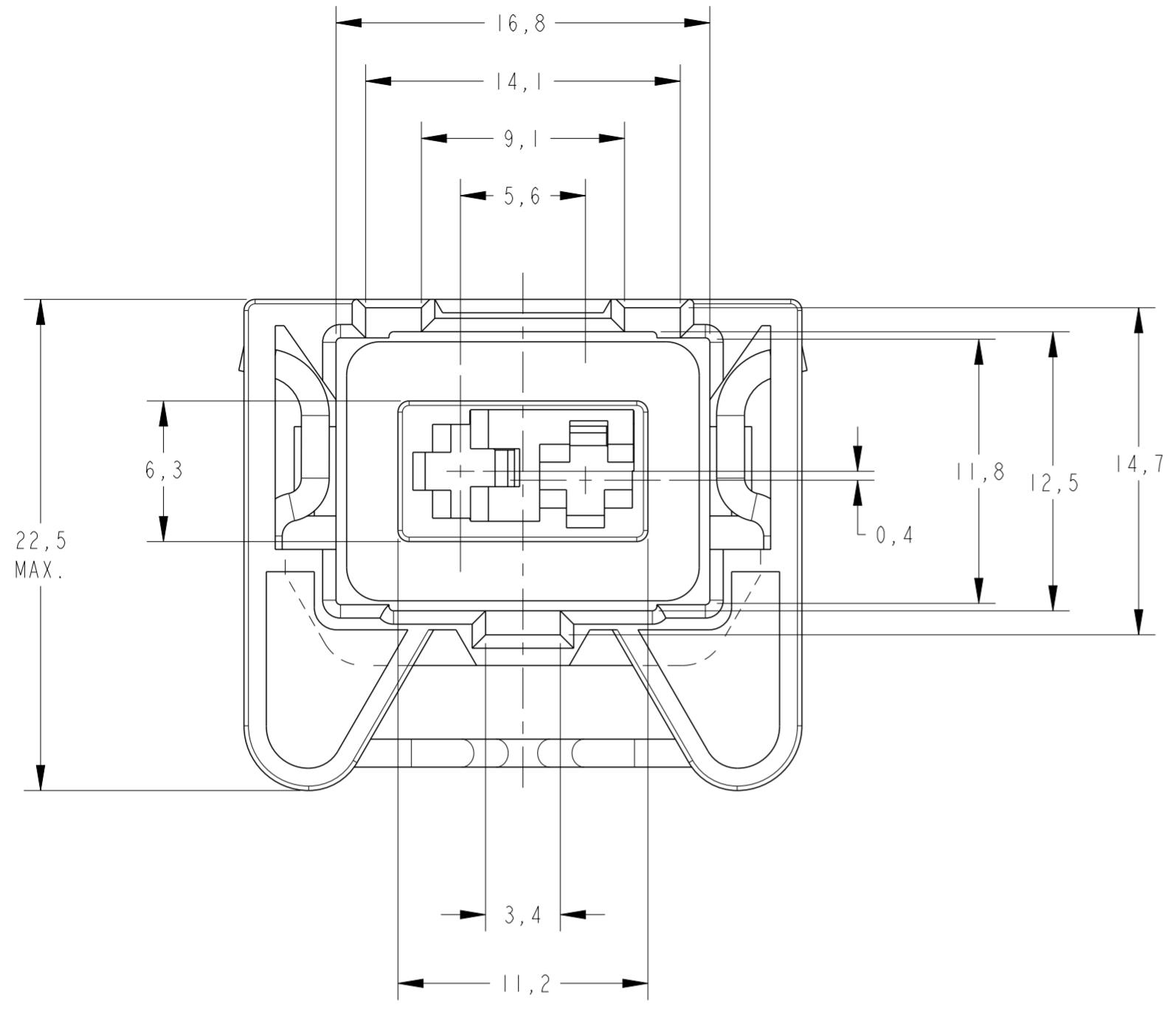

PERSPECTIVE VIEWS
 SCALE 1:1

- △ - A POSIÇÃO DE PRÉ-MONTAGEM DEVE SER MANTIDA ENTRE OS ITENS 1 E 2, COMO SERÃO FORNECIDOS.
- 2 - GRAVAÇÕES QUE DEVEM CONSTAR, CONF. TABELA AO LADO.
- 3 - CAVIDADE PARA TERMINAL JUNIOR POWER TIMER COM WIRE SEAL.
- △ - THE PRE MOUNTING POSITION MUST BE MAINTAINED WITHIN ITENS 1 AND 2, AS WILL SUPPLIED.
- 2 - MARKINGS ACC. BESIDE TABLE.
- 3 - CAVITY FOR JUNIOR POWER TIMER WITH WIRE SEAL.

GRAVAÇÃO MARKING
LOGOTIPO AMP AMP LOGO
CÓDIGO PAÍS PRODUTOR MANUFACTURER COUNTRY CODE
NÚMERO COMPONENTE AMP AMP COMPONENT NUMBER
NÚMERO CAVIDADE CAVITY NUMBER
IDENTIFICAÇÃO CIRCUITO CIRCUIT IDENTIFICATION
PAÍS PRODUTOR MANUFACTURER COUNTRY

D2

ITEM	DESCRIPTION	MATERIAL	FINISH
4	SPRING 2 POSN., JPT	AÇO INOX / STAINLESS STEEL	— / —
3	RUBBER SEAL	SILICONE	LARANJA / ORANGE
2	SPACER 2 POSN. 90°, JPT	PBT	AMARELO / YELLOW
1	HOUSING 2 POSN. 90°, JPT	PBT+30% F.V. / G.F.	AMARELO / YELLOW
1	HOUSING 2 POSN. 90°, JPT	PBT+30% F.V. / G.F.	VERDE / GREEN
1	HOUSING 2 POSN. 90°, JPT	PBT+30% F.V. / G.F.	AZUL / BLUE
1	HOUSING 2 POSN. 90°, JPT	PBT+30% F.V. / G.F.	MARROM / BROWN
1	HOUSING 2 POSN. 90°, JPT	PBT+30% F.V. / G.F.	CINZA CLARO / LIGH GRAY
1	HOUSING 2 POSN. 90°, JPT	PBT+30% F.V. / G.F.	VERMELHO / RED
1	HOUSING 2 POSN. 90°, JPT	PBT+30% F.V. / G.F.	NATURAL
1	HOUSING 2 POSN. 90°, JPT	PBT+30% F.V. / G.F.	PRETO / BLACK

THIS DRAWING IS A CONTROLLED DOCUMENT.

DWN: A. PERUSSI 15FEB02
 CHK: P. L. FARIA 15FEB02
 APVD: D. A. OLIVEIRA 15FEB02

STE TE Connectivity

NAME: HOUSING ASS'Y., 2 POSN. JUNIOR POWER TIMER

SIZE: A2 CAGE CODE: - DRAWING NO: 444071 RESTRICTED TO: -

MATERIAL: SEE TABLE TOLERANCES UNLESS OTHERWISE SPECIFIED: SEE TABLE

Customer Drawing SCALE: 2:1 SHEET: 1 OF 1 REV: D2