

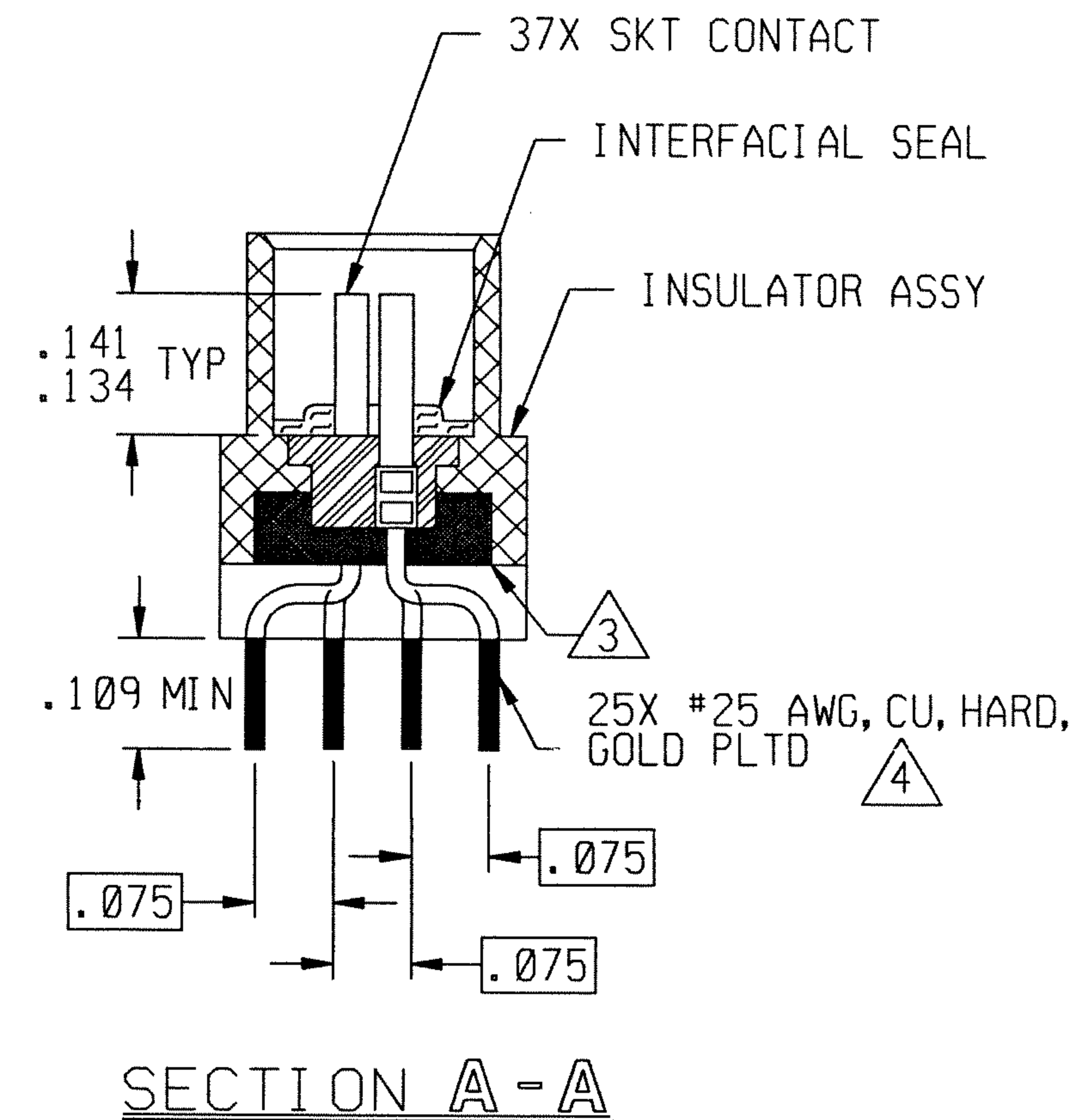

REVISION					
ZONE	LTR	ECN	DESCRIPTION	DATE	APPROVED
B		40249	UPDATE NOTES 1 & 2.	6-8-0	<i>[Signature]</i>
C			UPDATE PER ECO-10-017486	8/25/10	PJS

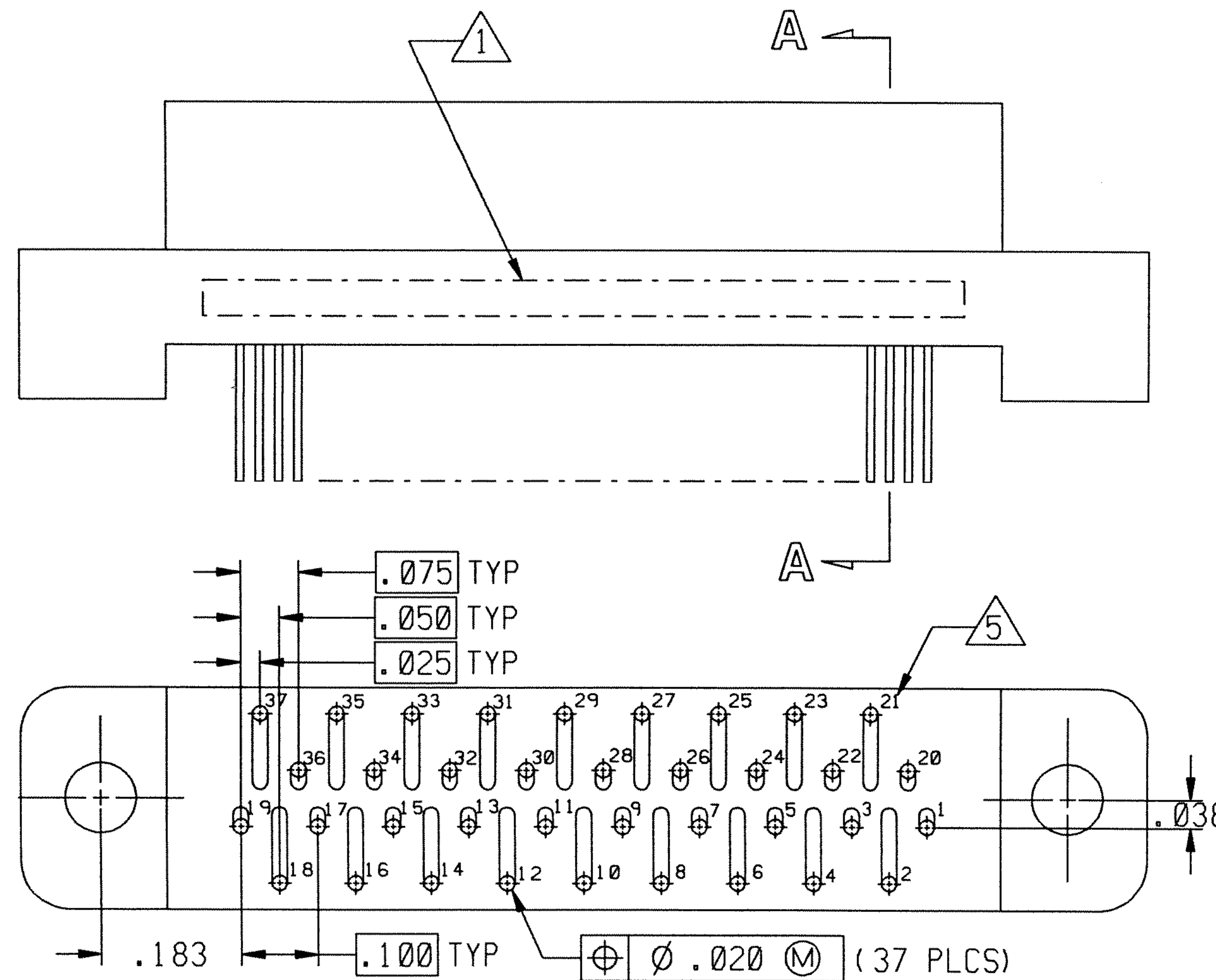
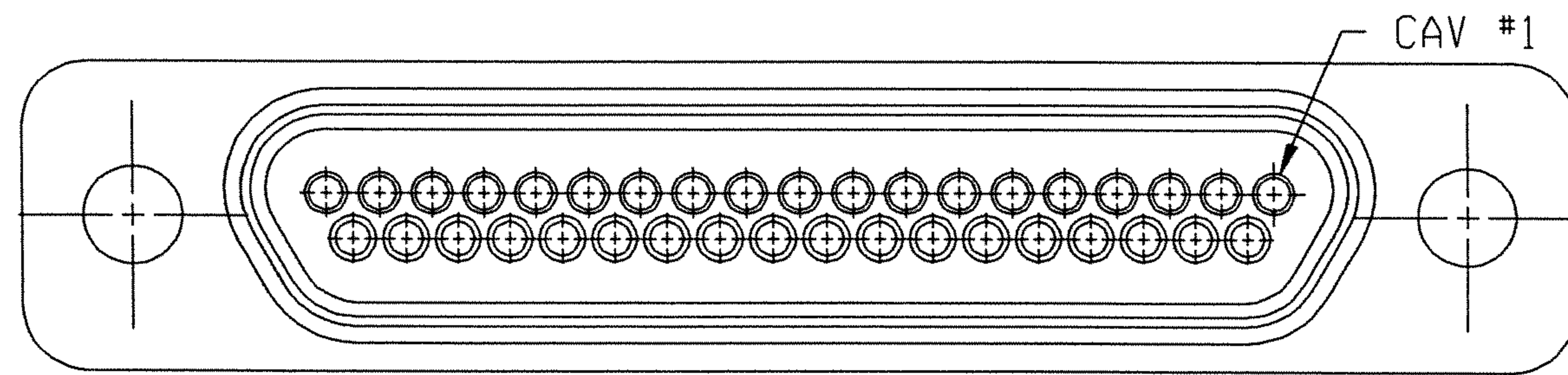

NOTES: UNLESS OTHERWISE SPECIFIED

- 1. MARK PER TPD.
- 2. CRIMP LEADS INTO CONTACTS PER MEP 302-05.
- 3. EPOXY AS SHOWN.
- 4. TERMINAL WIRES ARE TO BE SOLDER DIPPED UP TO THE MOUNTING SURFACE MINIMUM.
- 5. LEAD IDENTIFICATIONS ARE FOR REF ONLY. DO NOT APPEAR ON THE PART.

UNLESS OTHERWISE SPECIFIED DIMENSIONS ARE IN INCHES. TOLERANCE ARE:		APPROVALS		 MICRODOT CONNECTORS A DIVISION OF UNI-STAR INDUSTRIES INC. 306 PASADENA AVE., SO. PASADENA, CA 91030	PROD CODE 845
FRACTIONS ± 1/8	DECIMALS .XX ± .01 .XXX ± .005	ANGLES ± 2°	SIGNATURE		
MATERIAL:			CHECKED		METAL SHELL "D" CONNECTOR RCPT MCK-**-B-37SST2 094-5606-0003
FINISH:			PRD. ENG.	<i>[Signature]</i> 6-8-0	
			APPROVED		
THIS DOCUMENT IS THE PROPERTY OF MICRODOT CONNECTORS, A DIVISION OF UNI-STAR INDUSTRIES INC. USE OF THIS DOCUMENT OR ANY PART THEREOF IS STRICTLY FORBIDDEN WITHOUT THE EXPRESS WRITTEN PERMISSION OF MICRODOT CONNECTORS, A DIVISION OF UNI-STAR INDUSTRIES INC.		SIZE	CODE IDENT NO.	DRAWING NO.	CODE M
		B	98278	4-1532012-6	
SCALE: NONE				SHEET 1 OF 1	