

LOC	DIST	P	F	ZONE	LTR	DESCRIPTION	DATE	APPD
G	14				C	REVISED PER 0720-0937-96	31MAY96	OKS MJS

METRIC
 DIMENSIONS LISTED IN mm [INCHES]

AMP WIRE RANGE	UL E13288 Listed
22-16 AWG STRANDED	22-16 AWG STRANDED
SR LR7189 Certified	MILITARY P/N AND CLASS
NOT CERTIFIED	NOT APPLICABLE

⚠ STAMP AMP 22-18* APPROX AS SHOWN
 22-16 TERMINALS ARE STAMPED 22-18 IN
 ACCORDANCE WITH MILITARY SPECIFICATION
 MIL-T-7928; COMMERCIAL WIRE RANGE IS 22-16

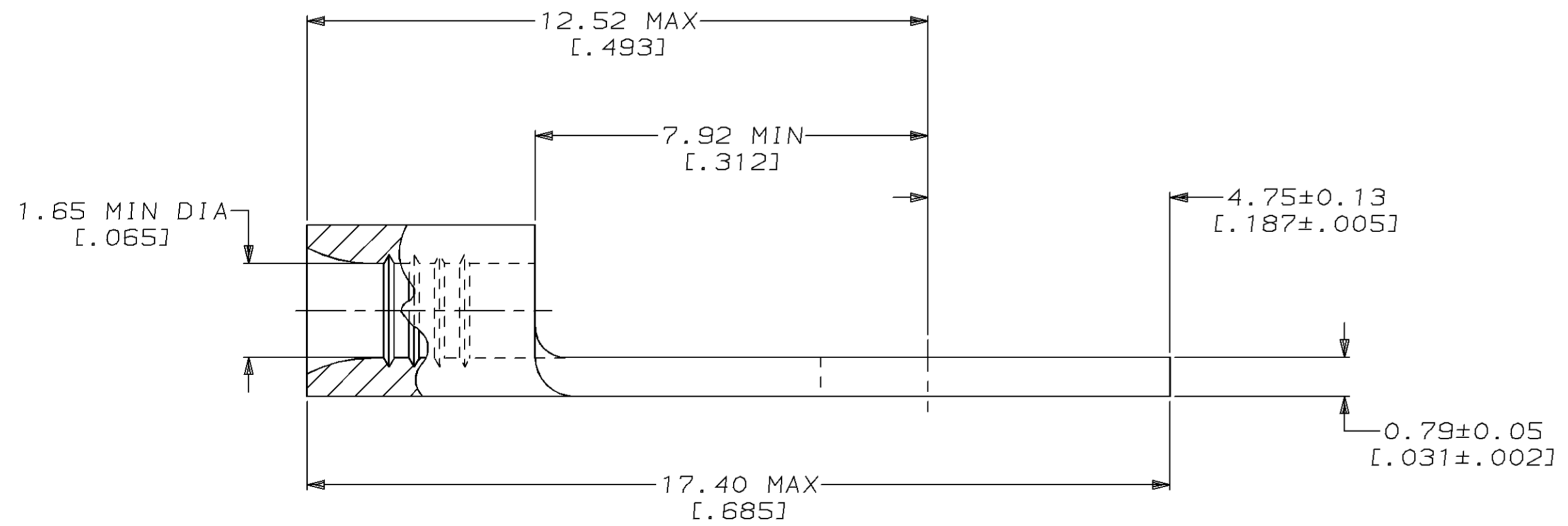
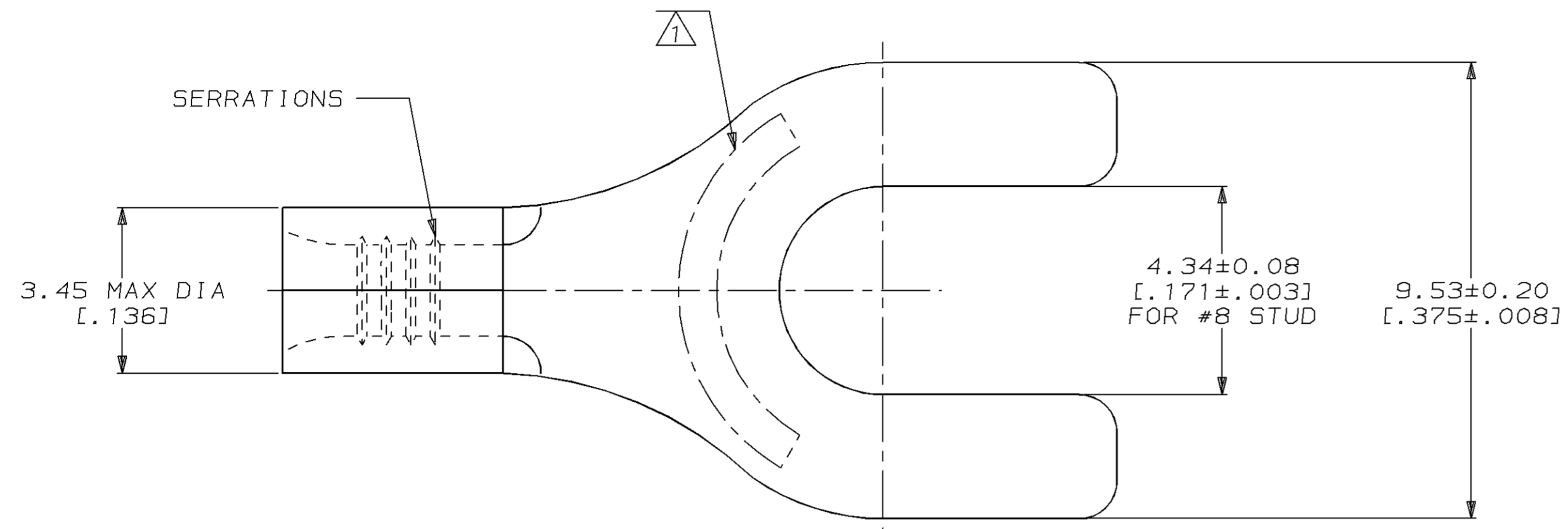

50	LOOSE PIECE, BOX	8-31635-2
-	LOOSE PIECE	31635
QUANTITY	PACKAGE TYPE	PART NO

AMP INCORPORATED
CUSTOMER SERVICE SYSTEMS

FOR ADDITIONAL PRODUCT INFORMATION OR COPIES OF DRAWINGS AND TECHNICAL DOCUMENTS	PRODUCT INFORMATION CENTER 1-800-522-6752
FOR APPLICATION TOOLING INFORMATION	TOOLING ASSISTANCE CENTER 1-800-722-1111
FOR ORDER ENTRY	1-800-526-5142

MAX RECOMMENDED OPERATING
 TEMPERATURE:
 170°C MAX

VOLTAGE RATING:
 NOT APPLICABLE

WIRE CROSS SECTIONAL AREA RANGE:
 0.26-1.65mm² [509-3,260] CIR MILS
 STRANDED

THIS DRAWING IS A CONTROLLED DOCUMENT FOR
 AMP INCORPORATED. IT IS SUBJECT TO CHANGE
 AND THE CONTROLLING ENGINEERING ORGANIZATION
 SHOULD BE CONTACTED FOR THE LATEST REVISION.

DO NOT SCALE PRINT.
 UNLESS SPECIFIED
 DIMENSIONS IN mm [INCHES]
 TOLERANCES ON:
 2 PLC DEC ± -
 3 PLC DEC ± -
 ANGLES ± -

MATERIAL
 COPPER PER
 ASTM B-152
 ANNEALED

FINISH
 TIN PLATE
 0.00254[.000100] MIN
 THK PER MIL-T-10727

DR 2-17-93
 TA BRINKMAN

CHK 2-17-93
 DA PATTERSON

APPD 2-17-93
 DE MILLER

APPD 2-17-93
 JL MECKLEY

PRODUCT SPEC
 -

APPLICATION SPEC
 -

WEIGHT -

AMP AMP Incorporated
 Harrisburg, PA 17105-3608

NAME
**TERMINAL, SPADE TONGUE,
 BUDGET**

SIZE **C** CAGE CODE 00779 DRAWING NO **C-31635**

SCALE 10:1 SHEET 1 OF 1