

THIS DRAWING IS UNPUBLISHED. RELEASED FOR PUBLICATION  
 © COPYRIGHT 2010 BY TYCO ELECTRONICS CORPORATION. ALL RIGHTS RESERVED.

|     |     |                 |           |     |      |  |
|-----|-----|-----------------|-----------|-----|------|--|
| LOC | DW  | DIST            | REVISIONS |     |      |  |
| P   | LTR | DESCRIPTION     | DATE      | DWN | APVD |  |
|     | F   | (ECO-19-011949) | 26NOV2019 | R.R | S.H  |  |

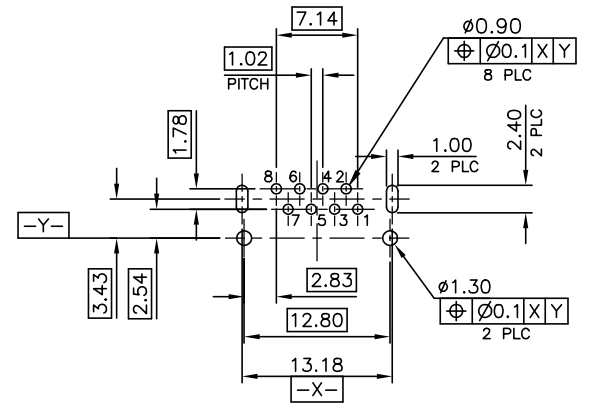

RECOMMENDED PCB LAYOUT (THICKNESS: 1.6MM)  
 (DIMENSION TOLERANCE: 1 PLC: ±0.1, 2 PLC: ±0.05)

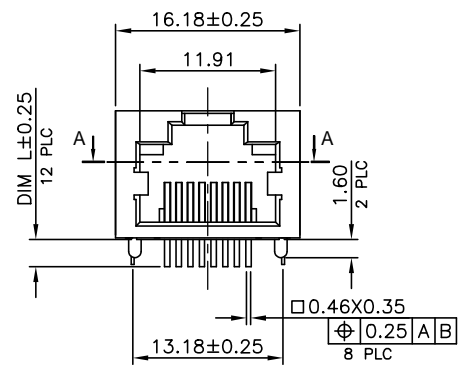
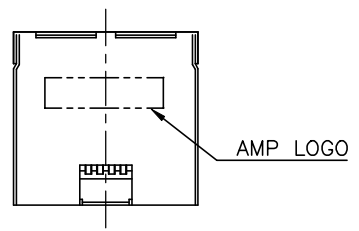
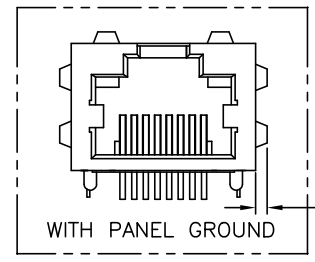
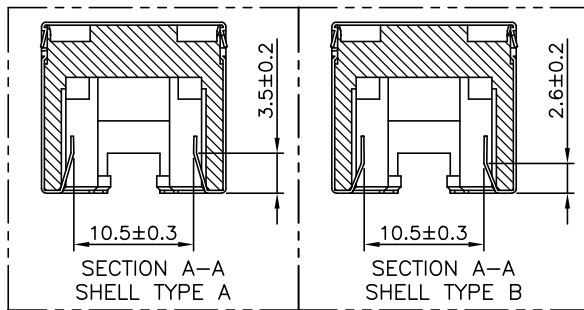
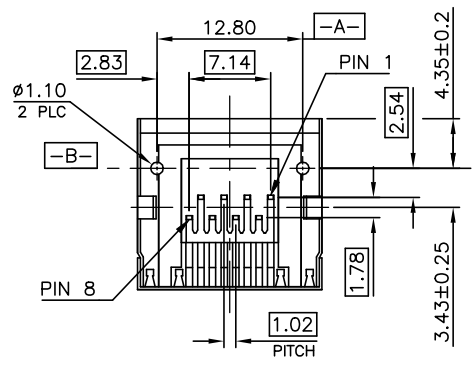
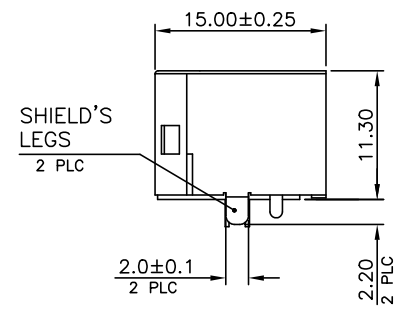
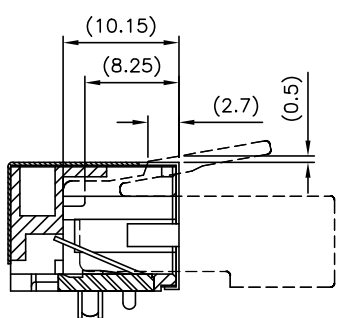

- NOTE:
- MATERIAL:
    - HOUSING: PA9T WITH 30% GF, UL94 V-0, BLACK COLOR.
    - CONTACTS: PHOSPHOR BRONZE.
    - SHELL: BRASS.
  - FINISH:
    - CONTACTS: (SEE TABLE) GOLD PLATED ON CONTACT AREA. GOLD FLASH ON SOLDER TAIL. 1.27um [50u"] MIN. NICKEL UNDERPLATED OVERALL.
    - SHELL: 0.51um [20u"] MIN. NICKEL PLATED.
  - WAVE SOLDER CAPABLE TO 265°C PER TYCO TEST SPEC. 109-202, CONDITION B.
- ⚠ OBSOLETE PART : OBSOLETE CIS STREAMLINING PER D.RENAUD/D.SINISI  
 ⚠ HOUSING: PA4T WITH GLASS FIBER, UL94 V-0, BLACK COLOR.  
 ⚠ LOW BR/CL AS DEFINED IN TEC-138-702.

| TAPE & REEL | W/O | TYPE A | 2.2 | 6u"       | 3-1734795-2          |
|-------------|-----|--------|-----|-----------|----------------------|
| OBSOLETE    | W/  | W/O    | 1.5 | 6u"       | 3-1734795-1          |
|             |     |        |     | 50u"      | <del>1734795-8</del> |
|             |     |        |     | 30u"      | 1734795-7            |
|             |     |        |     | 15u"      | 3-1734795-6          |
|             |     |        |     | 15u"      | 1734795-6            |
| TRAY        | W/O | W/O    | 2.4 | 6u"       | 1734795-5            |
|             |     |        |     | 50u"      | 1734795-4            |
|             |     |        |     | 30u"      | <del>1734795-3</del> |
|             |     |        |     | 15u"      | <del>1734795-2</del> |
|             |     |        | 6u" | 1734795-1 |                      |

|   |  |                  |            |           |  |
|---|--|------------------|------------|-----------|--|
| THIS DRAWING IS A CONTROLLED DOCUMENT.  |  | DWN              | O. HU      | 14SEP2007 | <br>TE Connectivity  |
| DIMENSIONS: mm  |  | CHK              | S. HOU     | 14SEP2007 |  |
| TOLERANCES UNLESS OTHERWISE SPECIFIED:  |  | APVD             | W.J. KE    | 14SEP2007 |  |
| 0 PLC ± -<br>1 PLC ± 0.3<br>2 PLC ± 0.2<br>3 PLC ± 0.15<br>4 PLC ± -<br>ANGLES ± 3° |  | PRODUCT SPEC     | 108-57535  |           |  |
| MATERIAL: SEE NOTE  |  | FINISH           | SEE NOTE   |           | NAME   |
|   |  | WEIGHT           | 3.5 GRAMS  |           | MODULAR JACK CONNECTOR<br>RJ45, 8P8C, SHIELDED<br>TAB UP, DIP TYPE, H=11.3mm |
|   |  | CUSTOMER DRAWING | SIZE       | A3        | CAGE CODE  |
|   |  |                  | DRAWING NO | C=1734795 | RESTRICTED TO  |
|   |  |                  | SCALE      | SHEET     | 1 OF 5   |
|   |  |                  | REV        | F         |  |

THIS DRAWING IS UNPUBLISHED. RELEASED FOR PUBLICATION  
 © COPYRIGHT 2010 BY TYCO ELECTRONICS CORPORATION. ALL RIGHTS RESERVED.

| LOC |  | DIST |  | REVISIONS    |     |             |      |     |      |
|-----|--|------|--|--------------|-----|-------------|------|-----|------|
| DW  |  |      |  | P            | LTR | DESCRIPTION | DATE | DWN | APVD |
|     |  |      |  | SEE SHEET 1. |     |             |      |     |      |

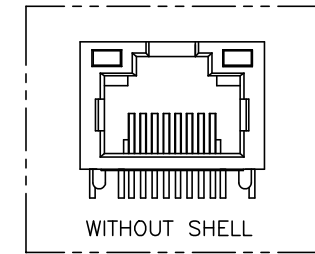

1-1734795-9

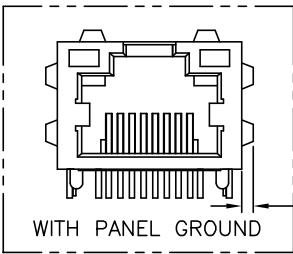

0.8~2.0  
6 PLC

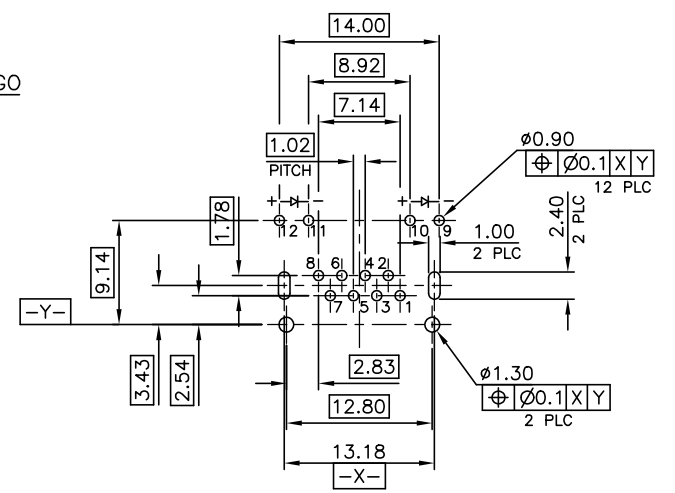
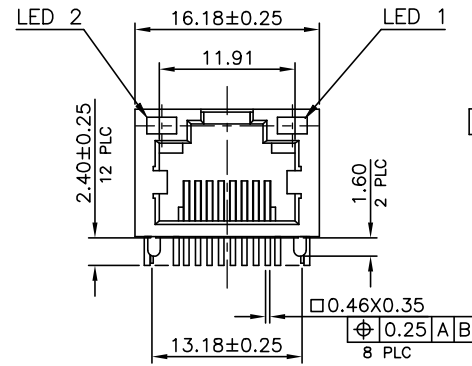
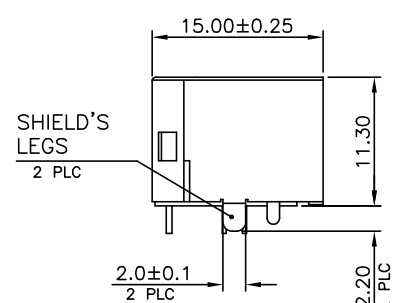
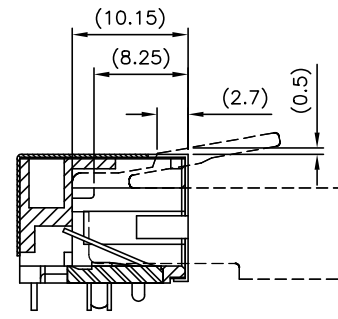
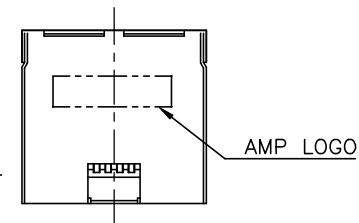

- NOTE:
- MATERIAL:
    - 1.1 HOUSING: PA9T WITH 30% GF, UL94 V-0, BLACK COLOR.
    - 1.2 CONTACTS: PHOSPHOR BRONZE.
    - 1.3 SHELL: BRASS.
    - 1.4 LED LIGHT: EPOXY RESIN & STEEL
  - FINISH:
    - 2.1 CONTACTS: (SEE TABLE) GOLD PLATED ON CONTACT AREA. GOLD FLASH ON SOLDER TAIL.
    - 2.2 SHELL: 0.51um [20u"] MIN. NICKEL PLATED.
    - 2.3 LED: 1.02um [40u"] COPPER UNDERPLATED OVERALL.
      - 1.27um [50u"] NICKEL OVERALL.
      - 1.27um [50u"] SILVER ON BONDING AREA.
      - 2.54um [100u"] BRIGHT-TIN ON SOLDER AREA.
  - WAVE SOLDER CAPABLE TO 265°C PER TYCO TEST SPEC. 109-202, CONDITION B.
- ⚠️ OBSOLETE PART : OBSOLETE CIS STREAMLINING PER D.RENAUD/D.SINISI  
 ⚠️ LED: 1.02um [40u"] COPPER UNDERPLATED OVERALL  
 0.5um [20u"] NICKEL OVERALL  
 1.27um [50u"] SILVER ON BONDING AREA  
 2.54um [100u"] BRIGHT-TIN ON SOLDER AREA  
 ⚠️ WITHOUT OUTER SHELL

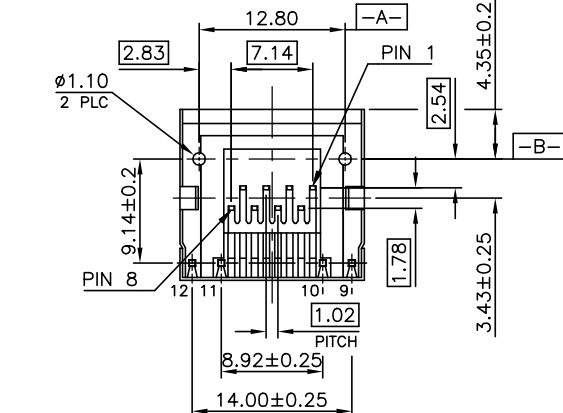

| FINISH          | LED 2      | LED 1  | MIN. GOLD THICKNESS | PART NUMBER |
|-----------------|------------|--------|---------------------|-------------|
| W/ GREEN/YELLOW | GREEN      | GREEN  | 50u"                | 2-1734795-8 |
|                 | GREEN      | GREEN  | 15u"                | 2-1734795-2 |
|                 |            |        | 50u"                | 1-1734795-8 |
| OBSOLETE        | W/ ORANGE  | YELLOW | 30u"                | 1-1734795-7 |
| OBSOLETE        |            |        | 15u"                | 1-1734795-6 |
|                 |            |        | 6u"                 | 1-1734795-5 |
| OBSOLETE        |            |        | 50u"                | 1-1734795-4 |
| OBSOLETE        | W/O YELLOW | GREEN  | 30u"                | 1-1734795-3 |
| OBSOLETE        |            |        | 15u"                | 1-1734795-2 |
|                 |            |        | 6u"                 | 1-1734795-9 |
|                 |            |        | 6u"                 | 1-1734795-1 |

THIS DRAWING IS A CONTROLLED DOCUMENT.

|     |     |      |              |                  |           |       |        |     |
|-----|-----|------|--------------|------------------|-----------|-------|--------|-----|
| DWN | CHK | APVD | PRODUCT SPEC | APPLICATION SPEC | WEIGHT    | SCALE | SHEET  | REV |
|     |     |      |              |                  | 3.5 GRAMS |       | 2 of 5 | F   |

TE Connectivity

MODULAR JACK CONNECTOR  
RJ45, 8P8C, SHIELDED  
TAB UP, DIP TYPE, H=11.3mm

SIZE: A3 CAGE CODE: 00779 C=1734795

CUSTOMER DRAWING

THIS DRAWING IS UNPUBLISHED. RELEASED FOR PUBLICATION  
© COPYRIGHT 2010 BY TYCO ELECTRONICS CORPORATION. ALL RIGHTS RESERVED.

| LOC | DIST | REVISIONS    |      |     |      |
|-----|------|--------------|------|-----|------|
| P   | LTR  | DESCRIPTION  | DATE | DWN | APVD |
| DW  |      | SEE SHEET 1. |      |     |      |

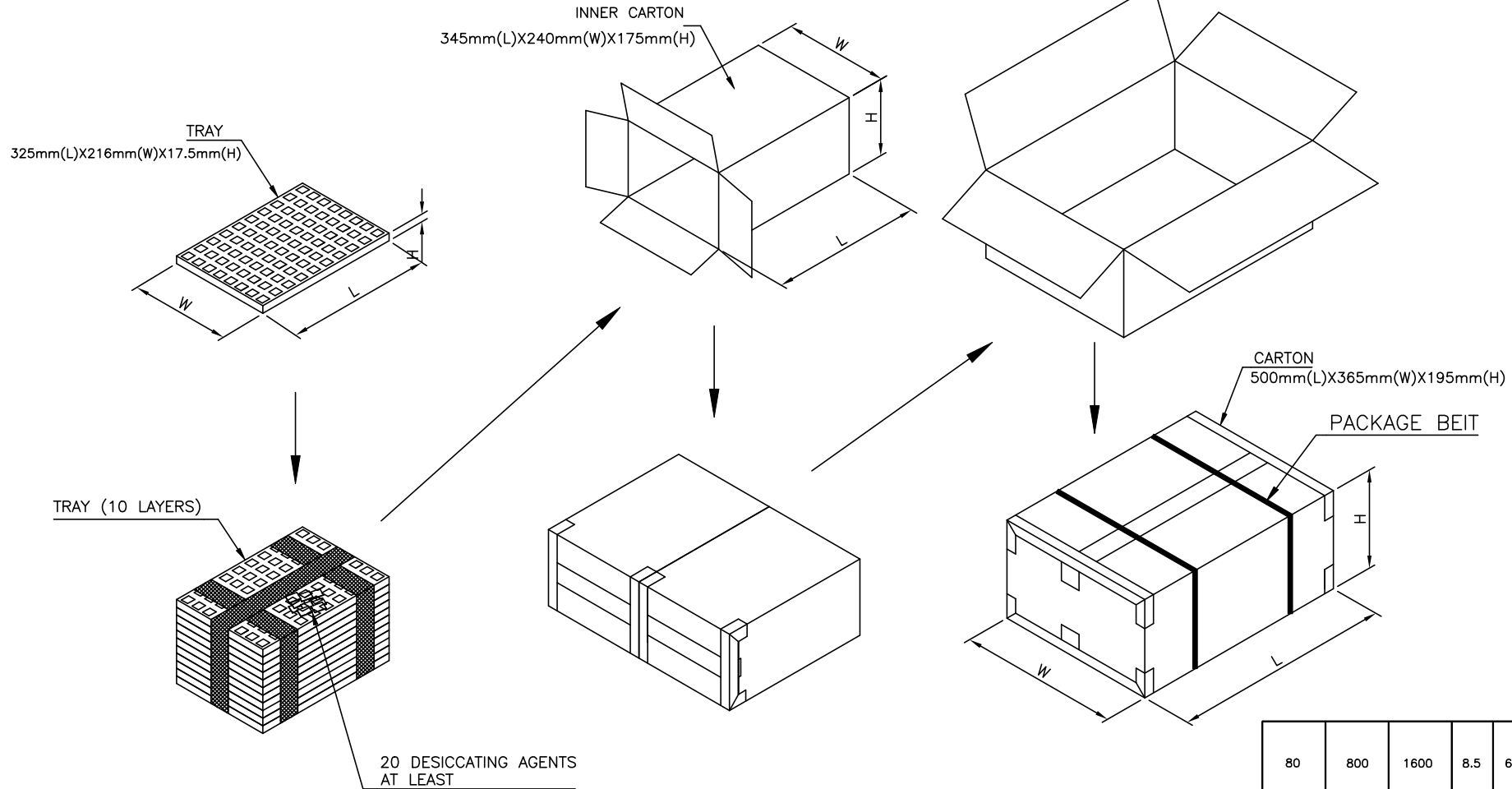

|          |              |                |          |          | 1734795-4            |
|----------|--------------|----------------|----------|----------|----------------------|
|          |              |                |          |          | <del>1734795-3</del> |
|          |              |                |          |          | <del>1734795-2</del> |
|          |              |                |          |          | 1734795-1            |
| PCS/TRAY | TRAYS/CARTON | QUANTITY (PCS) | G/W (Kg) | N/W (Kg) | PART NUMBER          |
| 80       | 800          | 1600           | 8.5      | 6.5      |                      |

|   |  |                  |  |  |  |
|---|--|------------------|--|--|--|
| THIS DRAWING IS A CONTROLLED DOCUMENT.  |  | DWN              |  | TE Connectivity  |  |
| DIMENSIONS: mm  |  | CHK              |  |  |  |
| TOLERANCES UNLESS OTHERWISE SPECIFIED   |  | APVD             |  |  |  |
| 0 PLC ± -<br>1 PLC ± 0.3<br>2 PLC ± 0.2<br>3 PLC ± 0.15<br>4 PLC ± -<br>ANGLES ± 3° |  | PRODUCT SPEC     |  |  |  |
| MATERIAL  |  | FINISH           |  | NAME   |  |
|   |  |                  |  | MODULAR JACK CONNECTOR<br>RJ45, 8P8C, SHIELDED<br>TAB UP, DIP TYPE, H=11.3mm |  |
|   |  | WEIGHT           |  | SIZE CAGE CODE DRAWING NO RESTRICTED TO                                      |  |
|   |  |                  |  | A3 00779 C=1734795   |  |
|   |  | CUSTOMER DRAWING |  | SCALE SHEET 3 OF 5 REV F   |  |

4

3

2

1

THIS DRAWING IS UNPUBLISHED. RELEASED FOR PUBLICATION  
© COPYRIGHT 2010 BY TYCO ELECTRONICS CORPORATION. ALL RIGHTS RESERVED.

|           |      |              |      |     |      |
|-----------|------|--------------|------|-----|------|
| LOC<br>DW | DIST | REVISIONS    |      |     |      |
| P         | LTR  | DESCRIPTION  | DATE | DWN | APVD |
|           |      | SEE SHEET 1. |      |     |      |

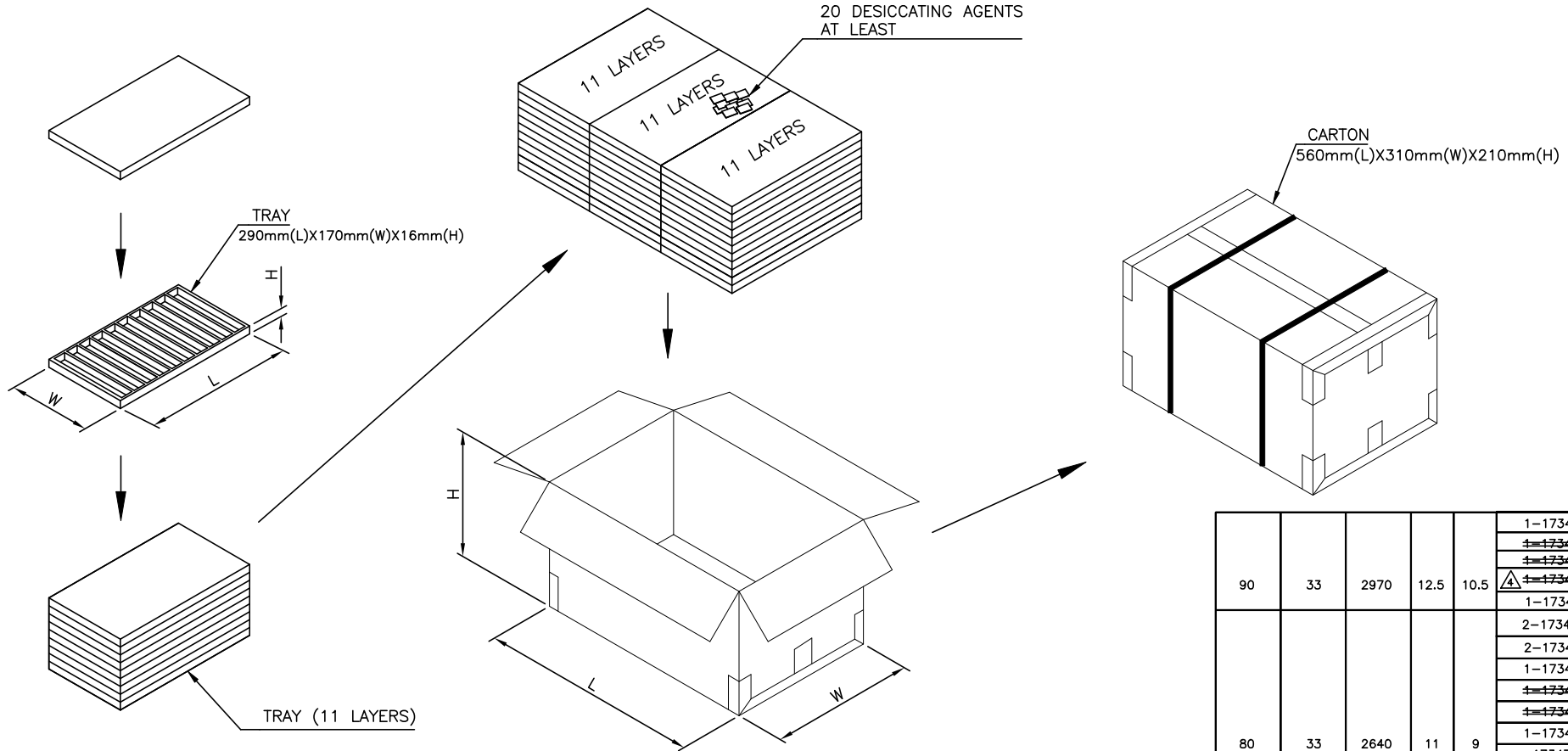

|          |              |                |          |          |                        |
|----------|--------------|----------------|----------|----------|------------------------|
| 90       | 33           | 2970           | 12.5     | 10.5     | 1-1734795-9            |
|          |              |                |          |          | <del>1-1734795-4</del> |
|          |              |                |          |          | <del>1-1734795-3</del> |
|          |              |                |          |          | <del>1-1734795-2</del> |
|          |              |                |          |          | 1-1734795-1            |
|          |              |                |          |          | 2-1734795-8            |
|          |              |                |          |          | 2-1734795-2            |
|          |              |                |          |          | 1-1734795-8            |
|          |              |                |          |          | <del>1-1734795-7</del> |
|          |              |                |          |          | <del>1-1734795-6</del> |
| 80       | 33           | 2640           | 11       | 9        | 1-1734795-5            |
|          |              |                |          |          | <del>1-1734795-8</del> |
|          |              |                |          |          | 1734795-7              |
|          |              |                |          |          | 3-1734795-6            |
|          |              |                |          |          | 1734795-6              |
|          |              |                |          |          | 1734795-5              |
|          |              |                |          |          | 1734795-5              |
| PCS/TRAY | TRAYS/CARTON | QUANTITY (PCS) | G/W (kg) | N/W (kg) | PART NUMBER            |

|  |        |                  |                            |           |            |
|--|--------|------------------|----------------------------|-----------|------------|
| THIS DRAWING IS A CONTROLLED DOCUMENT. |        | DWN              | TE Connectivity            |           |            |
| DIMENSIONS: mm                         |        | CHK              | NAME                       |           |            |
| TOLERANCES UNLESS OTHERWISE SPECIFIED: |        | APVD             | MODULAR JACK CONNECTOR     |           |            |
| 0 PLC ± -                              |        | PRODUCT SPEC     | RJ45, 8P8C, SHIELDED       |           |            |
| 1 PLC ± 0.3                            |        | APPLICATION SPEC | TAB UP, DIP TYPE, H=11.3mm |           |            |
| 2 PLC ± 0.2                            |        | WEIGHT           | SIZE                       | CAGE CODE | DRAWING NO |
| 3 PLC ± 0.15                           |        | CUSTOMER DRAWING | A3                         | 00779     | ©=1734795  |
| 4 PLC ± -                              |        |                  | RESTRICTED TO              |           |            |
| ANGLES ± 3'                            |        |                  | SCALE                      |           |            |
| MATERIAL                               | FINISH |                  | SHEET 4 of 5               |           | REV F      |

THIS DRAWING IS UNPUBLISHED. RELEASED FOR PUBLICATION  
 © COPYRIGHT 2010 BY TYCO ELECTRONICS CORPORATION. ALL RIGHTS RESERVED.

| LOC | DIST | REVISIONS    |      |     |      |
|-----|------|--------------|------|-----|------|
| P   | LTR  | DESCRIPTION  | DATE | DWN | APVD |
|     |      | SEE SHEET 1. |      |     |      |

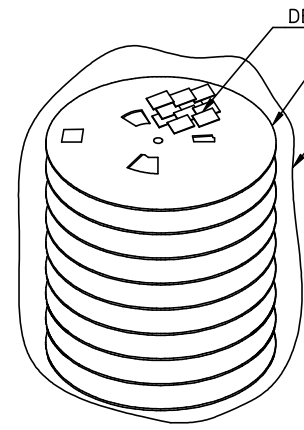
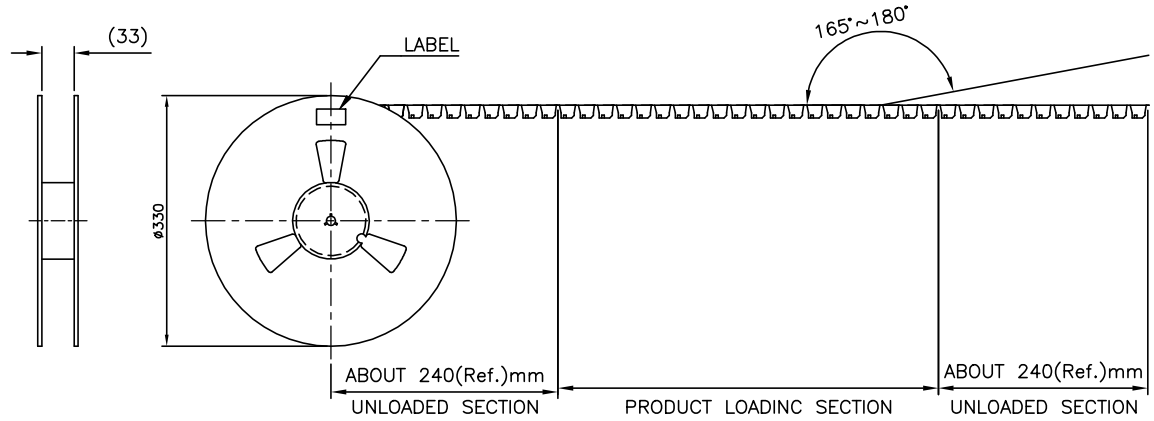

- NOTE:
- EACH BAG SHALL BE INCLUDED:  
\*DESICCANT
  - PEELING STRENGTH: 0.1~1.3N(1~130 GRAMS) FOR 12~56mm WIDE CARRIER TAPES
  - PEELING SPEED: 300mm/MINUTES.
  - PACKAGING MATERIAL:
    - COVER TAPE—COMPOSITE OF POLYETHYLENE TEREPHTHALATE (PET)
    - CARRIER—POLYSTYRENE (PS)
    - CARRIER REEL—POLYSTYRENE

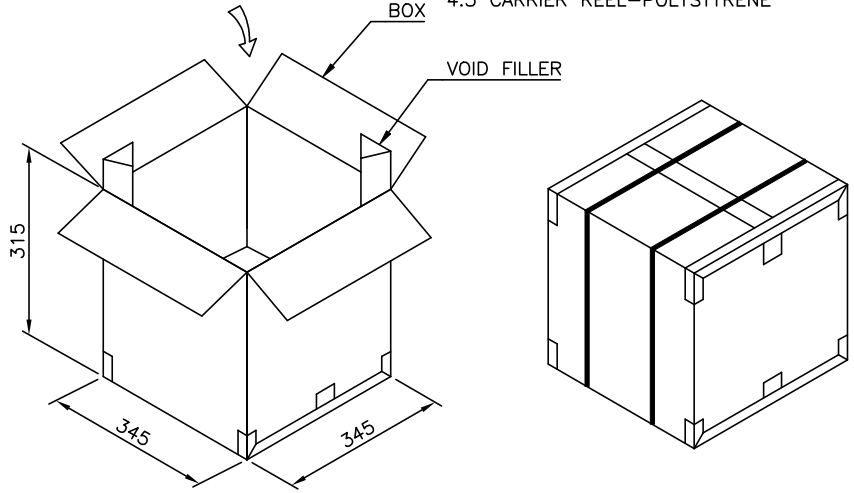
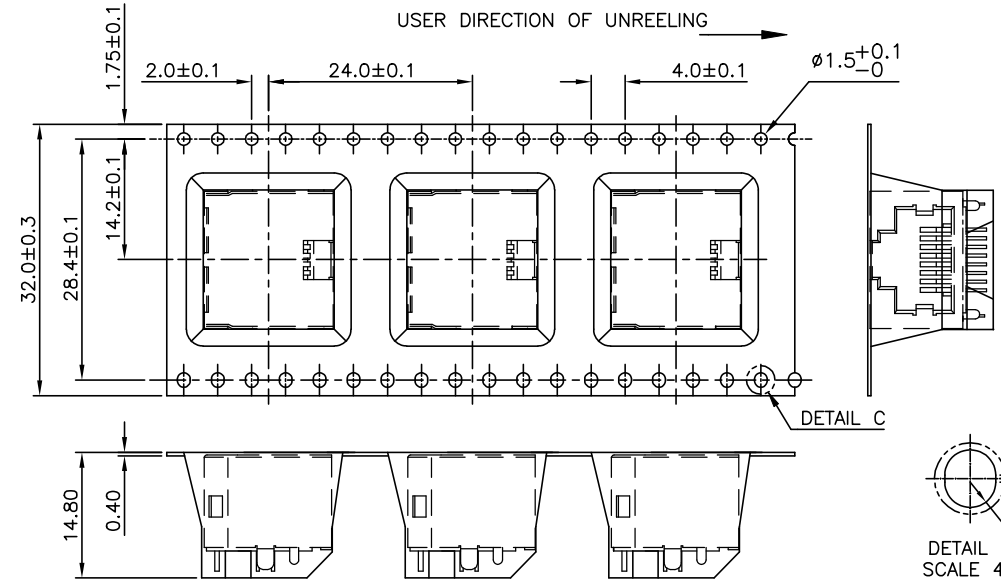

|              |            |          |          |         |             |
|--------------|------------|----------|----------|---------|-------------|
| 8.7 KG       | 5.05 KG    | 180      | 8        | 1440    | 3-1734795-2 |
| GROSS WEIGHT | NET WEIGHT | PCS/REEL | REEL/BOX | PCS/BOX | PART NUMBER |
|              |            |          |          |         | 3-1734795-1 |

|   |  |                  |   |               |            |
|---|--|------------------|---|---------------|------------|
| THIS DRAWING IS A CONTROLLED DOCUMENT.  |  | DWN              | TE Connectivity<br>MODULAR JACK CONNECTOR<br>RJ45, 8P8C, SHIELDED<br>TAB UP, DIP TYPE, H=11.3mm |               |            |
| DIMENSIONS: mm  |  | CHK              |   |               |            |
| TOLERANCES UNLESS OTHERWISE SPECIFIED:  |  | APVD             |   |               |            |
| MATERIAL  |  | PRODUCT SPEC     |   |               |            |
| FINISH  |  | APPLICATION SPEC | NAME  | RESTRICTED TO |            |
| 0 PLC ± -<br>1 PLC ± 0.3<br>2 PLC ± 0.2<br>3 PLC ± 0.15<br>4 PLC ± -<br>ANGLES ± 3° |  | WEIGHT           | SIZE  | CAGE CODE     | DRAWING NO |
|   |  | CUSTOMER DRAWING | A3  | 00779         | C=1734795  |
|   |  |                  | SCALE   | SHEET         | REV        |
|   |  |                  |   | 5 of 5        | F          |