

THIS DRAWING IS UNPUBLISHED. RELEASED FOR PUBLICATION N/A, N/A.  
 © COPYRIGHT N/A BY TYCO ELECTRONICS CORPORATION. ALL RIGHTS RESERVED.

LOC	DIST	REVISIONS					
DF	X0	P	LTR	DESCRIPTION	DATE	DWN	APVD
		0		PROPOSAL DRAWING	10-02	CT	DH

COMPONENT	MATERIAL	FINISH
CLAMP NUT HOUSING	STAINLESS STEEL PER ASTM-A-484 OR ASTM-A-582 TYPE 304	PASSIVATED PER ASTM-A-380
DIELECTRIC	FEP FLUOROPOLYMER PER ASTM-D-2116-95	-
CENTER CONTACT	BERYLLIUM COPPER PER ASTM-B-196 ALLOY C17300, CONDITION H	GOLD PLATED PER ASTM-B-488 OVER COPPER PER MIL-C-14550
MOUNTING NUT BUSHING	STAINLESS STEEL PER ASTM-A-484 OR ASTM-A-582 TYPE 304	PASSIVATED PER ASTM-A-380
LOCKWASHER	PHOSPER BRONZE PER QQ-B-750, GRADE B2	NICKEL PLATE PER QQ-N-290
GASKET	EPDM	-
COLLAR	STAINLESS STEEL PER ASTM-A-484 OR ASTM-A-582 TYPE 304	PASSIVATED PER ASTM-A-380

1. CAPTURED CENTER CONTACT.
2. CABLE: RAYCHEM 5U19J3922

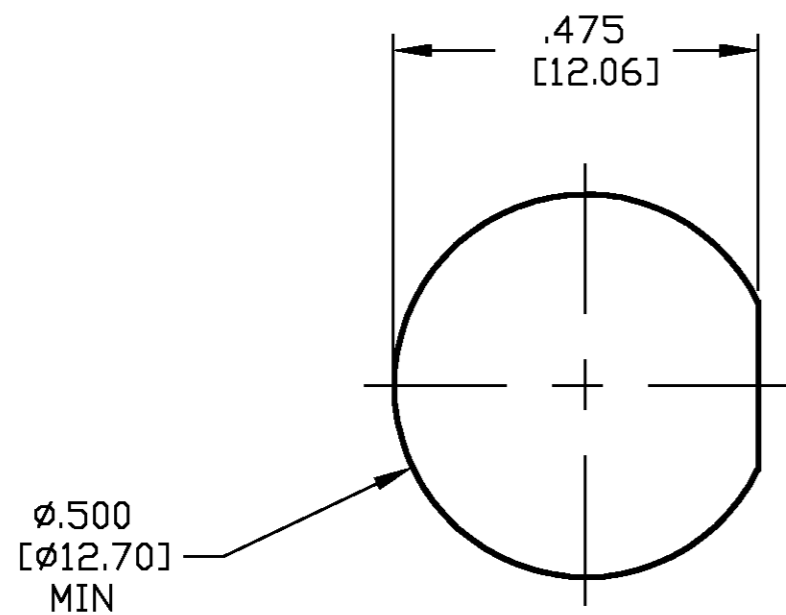

RECOMMENDED MOUNTING HOLE

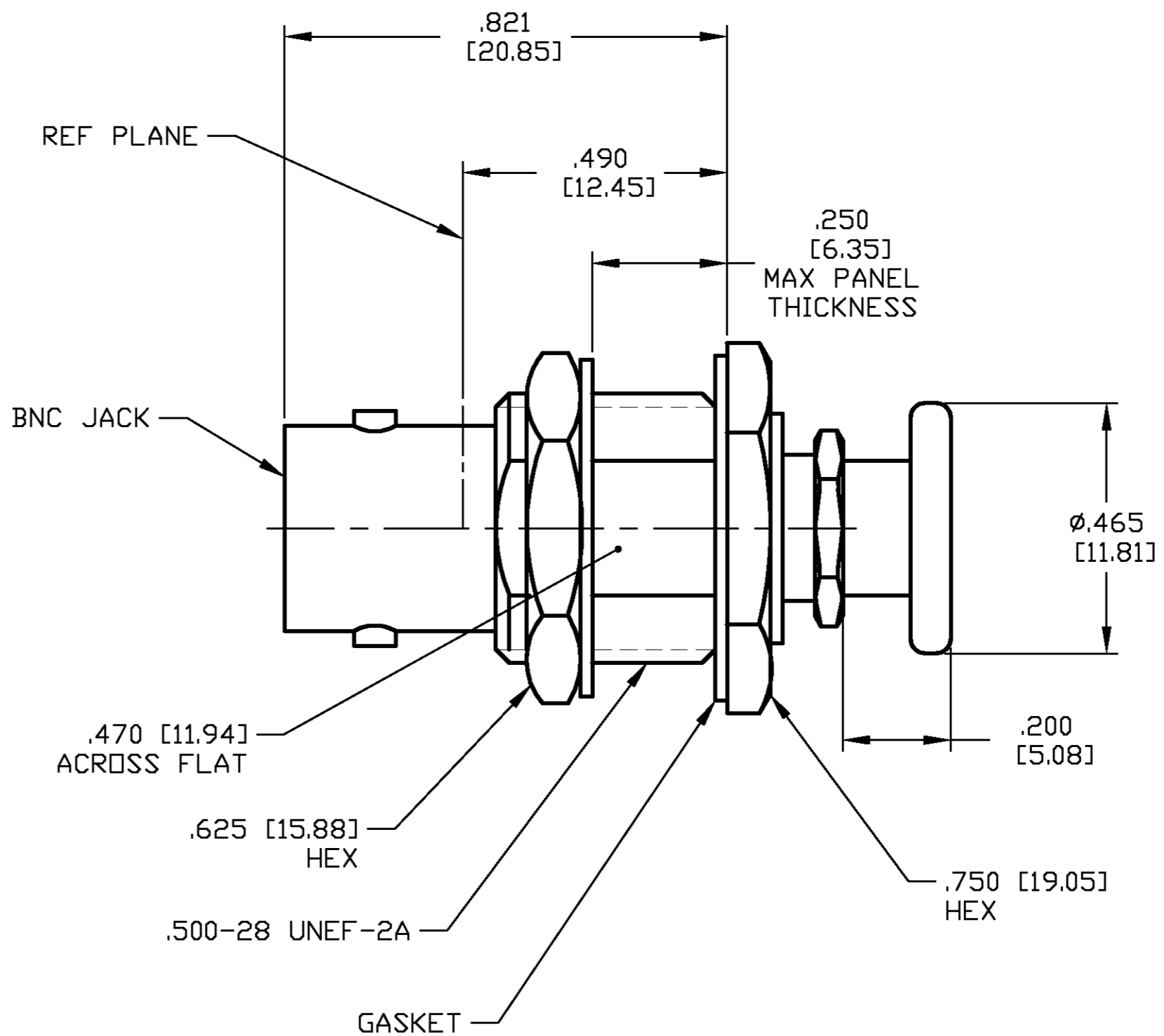

PRELIMINARY- NOT RELEASED FOR PRODUCTION

1663150-1  
PART NO.

THIS DRAWING IS A CONTROLLED DOCUMENT.		DWN C.C.THOMAS 10-16-02	Tyco Electronics Corporation Harrisburg, Pa 17105-3608	
DIMENSIONS: INCHES [mm]		CHK D.HOFFMAN 10-17-02	BNC BULKHEAD CABLE JACK ASSY, CLAMP ATTACHMENT	
TOLERANCES UNLESS OTHERWISE SPECIFIED: 0 PLC ± - 1 PLC ± - 2 PLC ± - 3 PLC ± .005 [0.13] 4 PLC ± - ANGLES ± -		APVD D.HOFFMAN 10-17-02	RESTRICTED TO	
MATERIAL SEE TABLE	FINISH SEE TABLE	PRODUCT SPEC APPLICATION SPEC	SIZE A2	CAGE CODE 00779
CUSTOMER DRAWING		WEIGHT -	DRAWING NO C-1663150	REV 0
		SCALE 4:1	SHEET 1 OF 1	