

Schnittstelle Befestigungsplatte
INTERFACE FOR MOUNTING PLATE

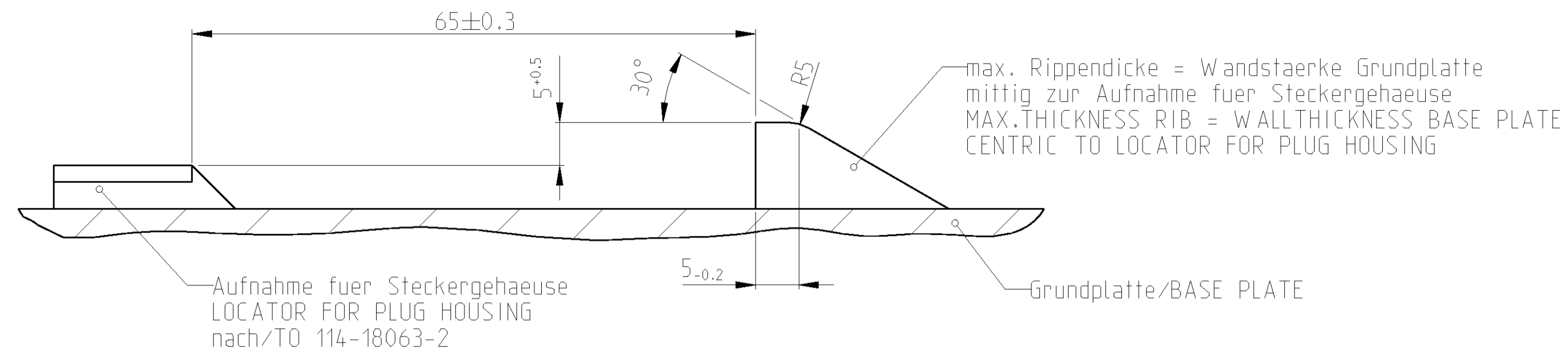

1:1
b MOST Pigtail Schutzkappe / MOST Pigtail dust cover
Material: PP-MF20
(50% Regranulat)
nach / T0 -
Farbe: schwarz
COLOR: BLACK

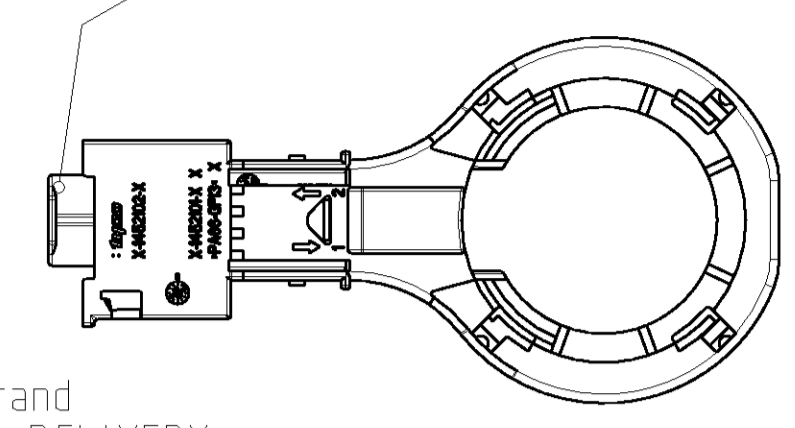

LOC	DIST	REV	DATE	BY	APPV
A1	-	D	03MAR2003	MS	ZS
		E	08APR2003	MS	ZS
		E1	19APR2004	MS	ZS

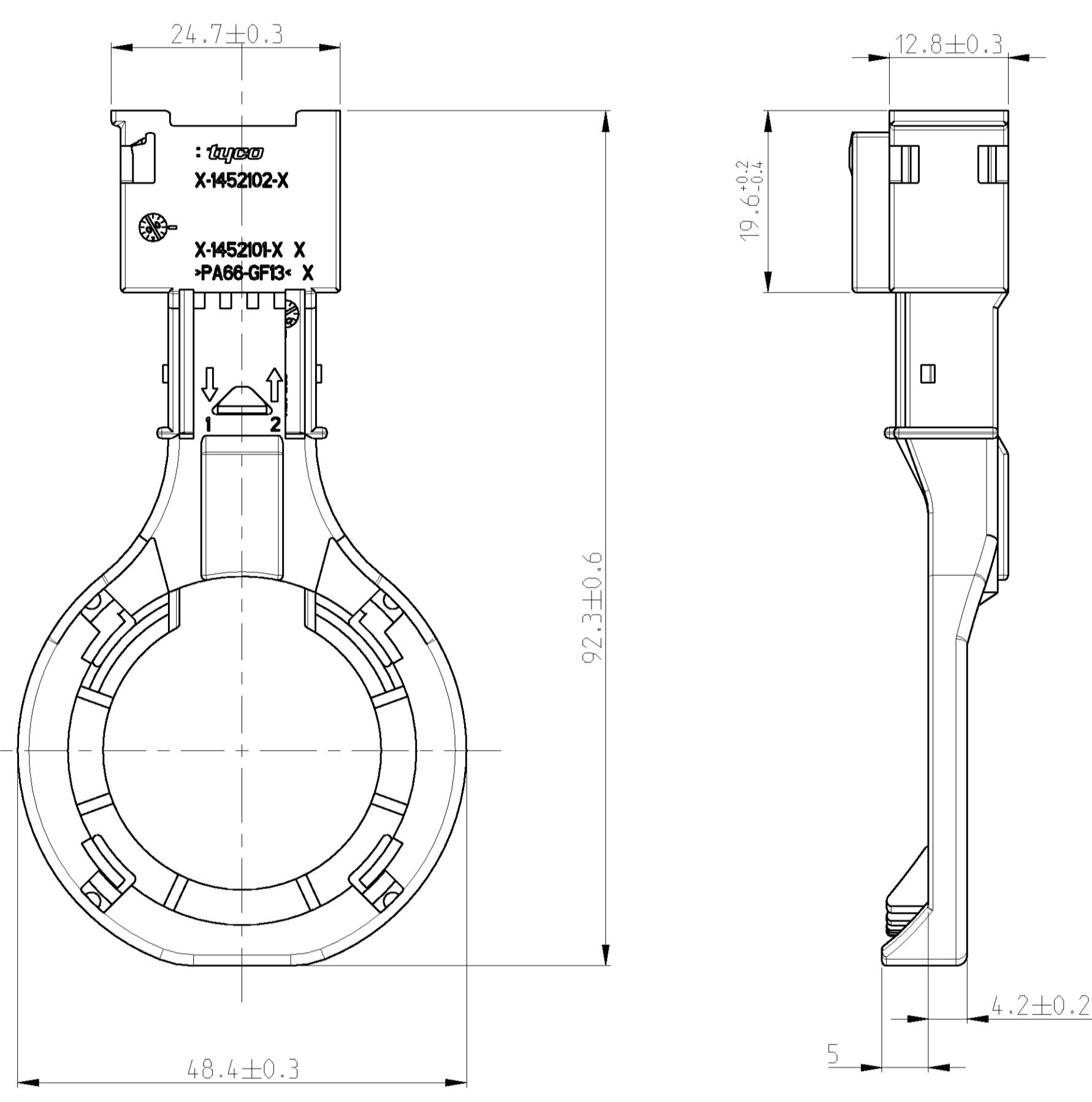

E1
b Feder / SPRING
Material: X12CrNi177
(-)
nach / T0 -
Farbe: blank
COLOR: PLAIN

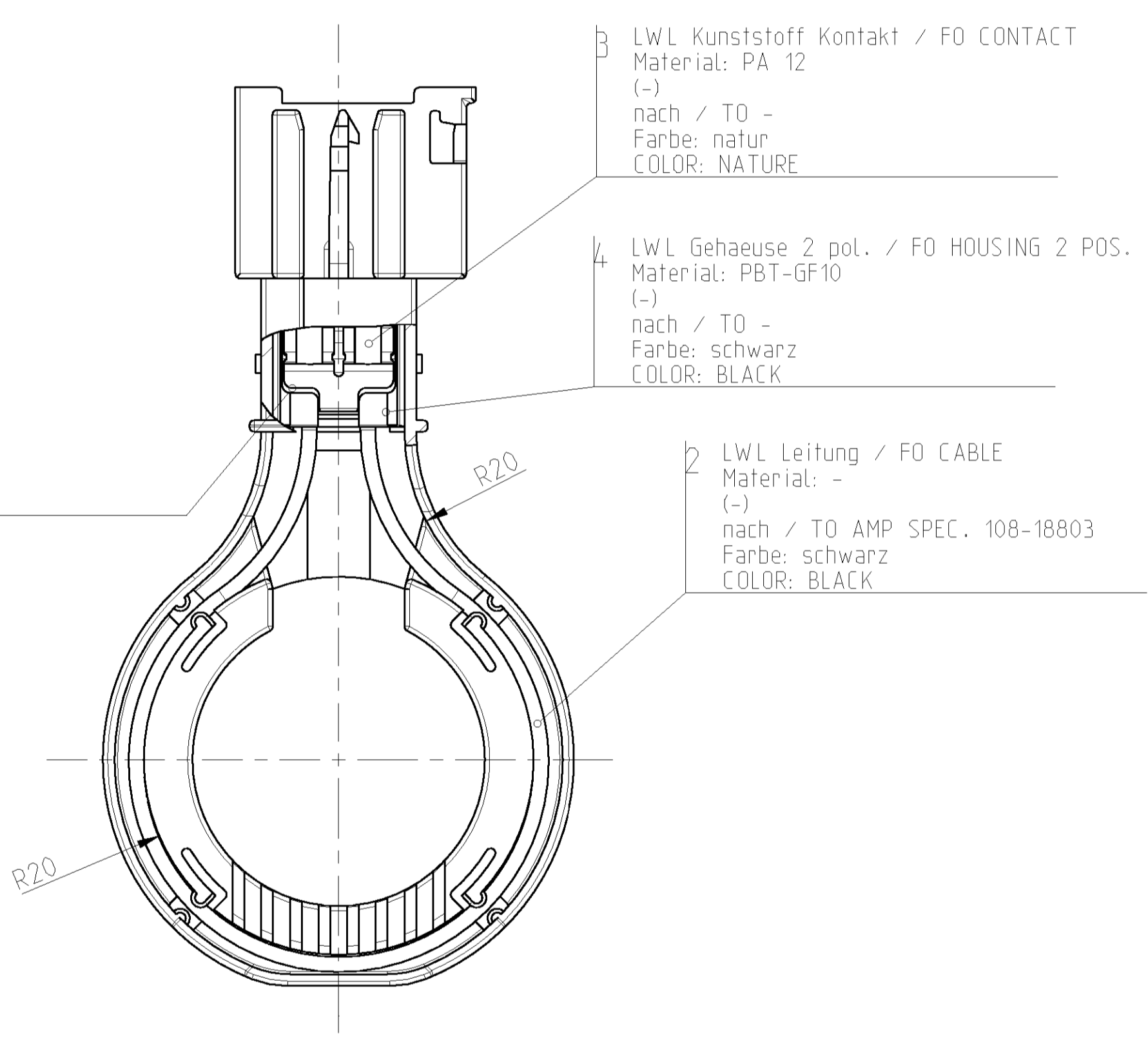

- Bemerkungen
NOTES
- 1 Massgebend ist der deutsche Text
ONLY THE GERMAN LANGUAGE VERSION SHALL BE BINDING
 - 2 Einzelheiten der Ausfuehrung bleiben dem Hersteller ueberlassen
DETAILS OF DESIGN ARE LEFT TO MANUFACTURER
 - 3 Formteilungsgrad max. 0.3 zulaessig
MOULD BURRS MAX. 0.3 PERMITTED
 - 4 Verpackung: Schuetttgut
PACKAGING: LOOSE PIECE
- 1- -1 wie gezeichnet
AS SHOWN

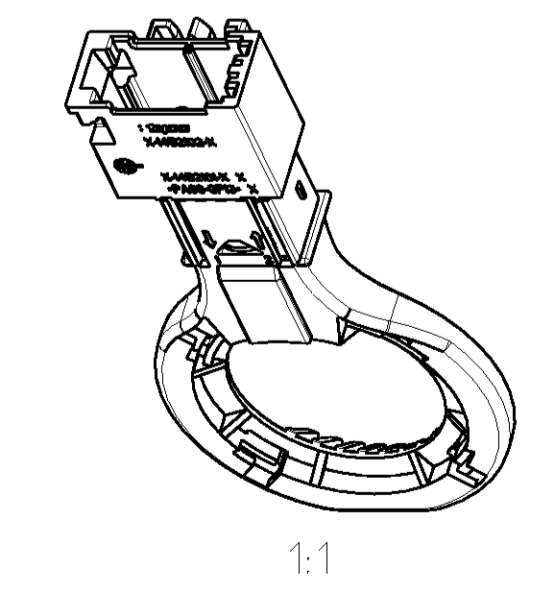
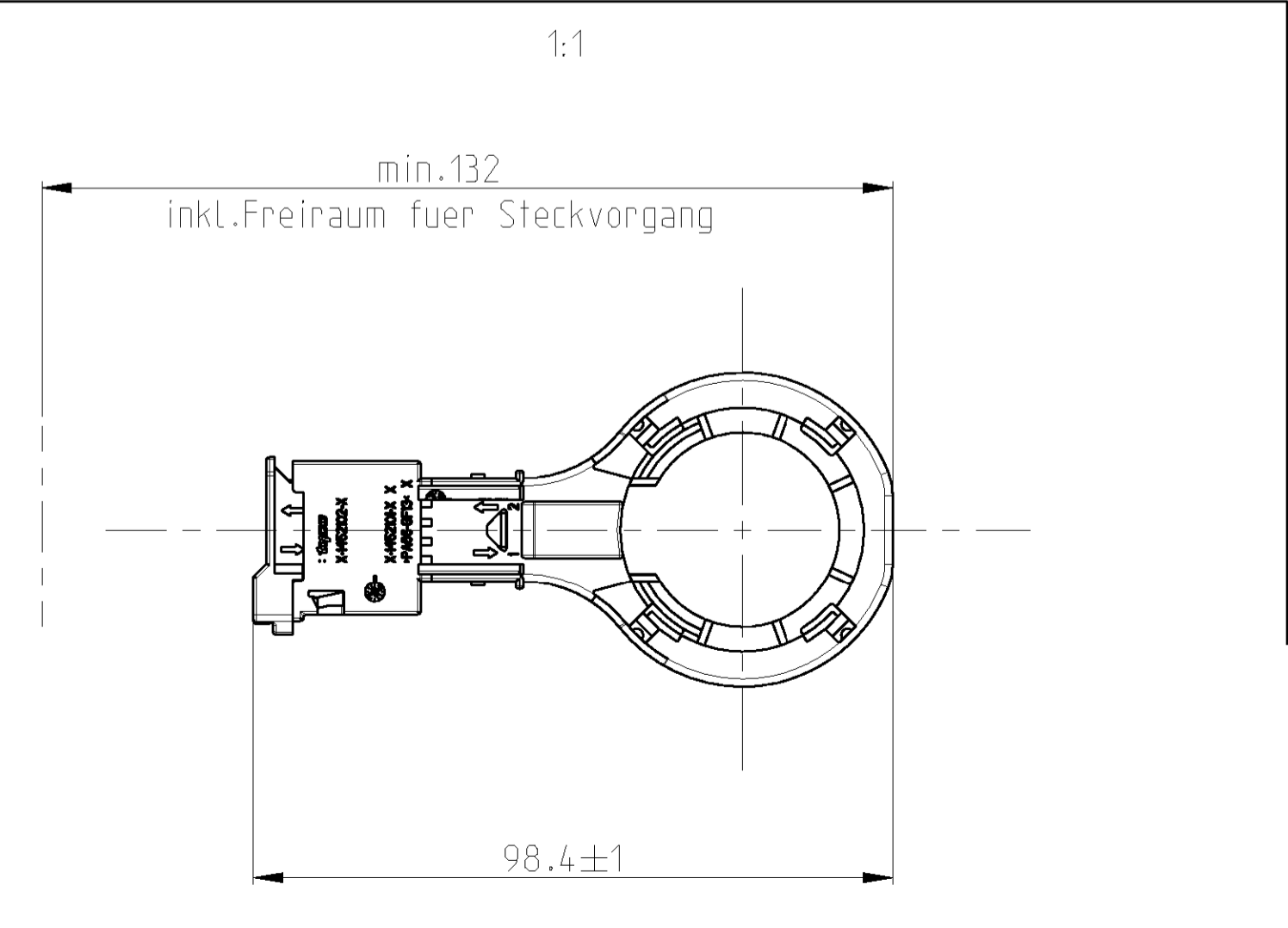
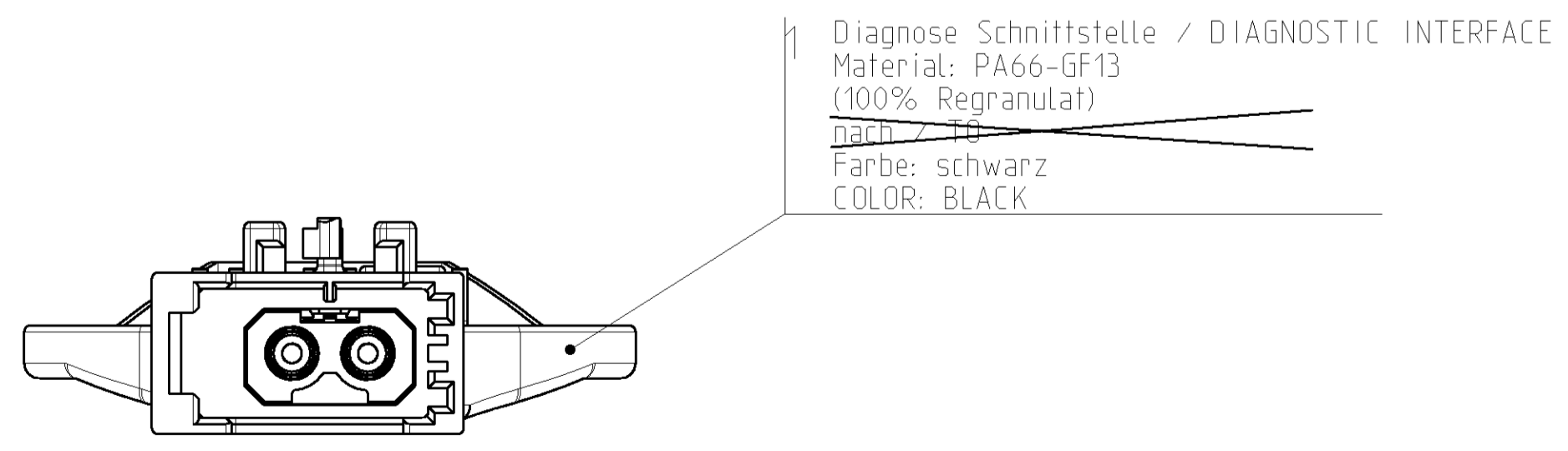

AMP BESTELL-NR. ORDER NO.	REV.	KOD. COD.	OBERFLAECHE SURFACE	FARBE/COLOR	ART KIND	GRAMM GEW WEIGHT	PASSEND ZU: SUITABLE FOR:	FO Steckergehäuse 2 pol. FO RECEPTACLE HSG.2 POS.	AMP
1-1452102-1	E	-	-	-	K	10	1-1355426-1		

LOC	DIST	REV	DATE	BY	APPV
A1	-	D	03MAR2003	MS	ZS
		E	08APR2003	MS	ZS
		E1	19APR2004	MS	ZS

tyco Electronics AMP GmbH
D - 64625 Bensheim

Diagnostic MOST Interface
MOST Diagnoseschnittstelle

00779
1452102

SCALE: 1:1
SHEET 1 OF 1
REV E1