

REVISIONS			
REV	DESCRIPTION	DATE	APPROVED
01 ₁	REDRAWN ON CAD ECN 94-0474 <i>RAC</i>	1/17/95	<i>RAC</i> 1/17/95

.190-36, UNS-2A
TYP

.250 HEX
6.4

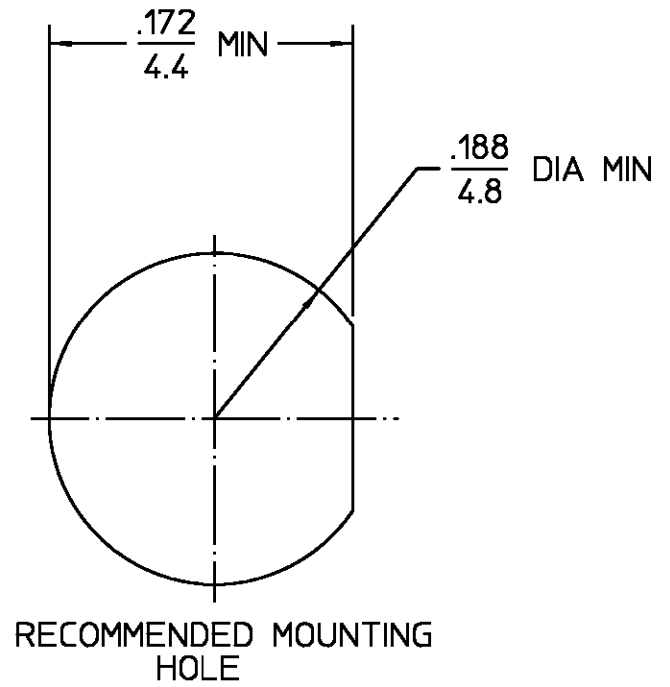

HOUSING MOUNTING NUT LOCKWASHER	STAINLESS STEEL PER ASTM-A484 AND ASTM- A582, TYPE 303	PASSIVATE PER QQ-P-35
DIELECTRIC	TFE FLUOROCARBON PER ASTM-D-1457	N/A
CENTER CONTACT	BERYLLIUM COPPER PER ASTM-B-196 OR ASTM-B-197, ALLOY C17300, CONDITION H	GOLD PLATE PER MIL-G-45204
COMPONENT	MATERIAL	FINISH

UNLESS OTHERWISE SPECIFIED DIMENSIONS ARE IN INCHES FRAC. DEC. ANGLES ± 1/64 ±.005 ± 1°	DRAWN BY D.CAM 1/18/79	 AMP Incorporated 140 Fourth Avenue Waltham, MA 02451-7599				
	CHECKED BY F.G. 1/22/79					
	APPD BY G.H. 1/22/79					
These drawings and specifications are the property of M/A COM Interconnect Div. and shall not be reproduced or copied or used in whole or in part as the basis for the manufacture or sale of item(s) without written permission.	USE ASSY PROCEDURE	TITLE OSSM BULKHEAD FEEDTHRU JACK RECEPTACLE-SOLDER TERMINAL				
	NO. A.P. N/A	<table border="1"> <tr> <td>SIZE B</td> <td>CODE IDENT NO. 26805</td> <td>1058-0000-02</td> <td>REV 01₁</td> </tr> </table>	SIZE B	CODE IDENT NO. 26805	1058-0000-02	REV 01 ₁
	SIZE B	CODE IDENT NO. 26805	1058-0000-02	REV 01 ₁		
	SCALE 10/1	SHEET 1 OF 1				

NOTES:
1. CAPTURED CENTER CONTACT

.XXX = in
XX.X = mm

CUSTOMER DRAWING

AMP PART # 1045637-1
SHEET 1 OF 1 REV A